

# Basic Mode Guide

## Agilent Technologies PSA Series Spectrum Analyzers

**Option B7J: Digital Demodulation**  
**Option 122: 80 MHz Bandwidth Digitizer**  
**Option 140: 40 MHz Bandwidth Digitizer**

**This manual provides documentation for the following instruments:**

### PSA Series

**E4440A (3 Hz – 26.5 GHz)**

**E4443A (3 Hz – 6.7 GHz)**

**E4445A (3 Hz – 13.2 GHz)**

**E4446A (3 Hz – 44.0 GHz)**

**E4447A (3 Hz – 42.98 GHz)**

**E4448A (3 Hz – 50.0 GHz)**



**Agilent Technologies**

**Manufacturing Part Number: E4440-90605**

**Supersedes: E4440-90341**

**Printed in USA**

**June 2008**

© Copyright 1999 - 2008 Agilent Technologies, Inc.

---

## **Notice**

The information contained in this document is subject to change without notice.

Agilent Technologies makes no warranty of any kind with regard to this material, including but not limited to, the implied warranties of merchantability and fitness for a particular purpose. Agilent Technologies shall not be liable for errors contained herein or for incidental or consequential damages in connection with the furnishing, performance, or use of this material.

---

## **Option 122 Software License Information**

Certain software components are licensed under the GNU GPL and LGPL.

Copyright © 1991-2008

LynuxWorks, Inc.

All Rights Reserved

---

## **Option 140 Software License Information**

Certain software components are licensed under the GNU GPL and LGPL. If both Options 122 and 140 are installed, the default is Option 122.

Copyright © 1991-2008

LynuxWorks, Inc.

All Rights Reserved

## 1. Introduction

What Does Basic Mode Do? . . . . .	18
Option B7J: Digital Demodulation Hardware . . . . .	19
Options 122 and 140: Wideband Digitizer Hardware . . . . .	20
Installing Optional Measurement Personalities . . . . .	21
Do You Have Enough Memory to Load All Your Personality Options? . . . . .	21
How to Predict Your Memory Requirements . . . . .	23
Memory Upgrade Kits. . . . .	26
Loading an Optional Measurement Personality . . . . .	26
Obtaining and Installing a License Key . . . . .	27
Viewing a License Key . . . . .	27
Using the Delete License Key on PSA . . . . .	29
Ordering Optional Measurement Personalities . . . . .	29

## 2. Making Measurements

Basic Measurements . . . . .	32
PSA Options 122 and 140 Programming Control . . . . .	32
Setting up and Making a Measurement . . . . .	33
Making the Initial Signal Connection . . . . .	33
Using Instrument Mode and Measurement Presets . . . . .	33
The 3 Steps to Set Up and Make Measurements . . . . .	34
Spectrum (Frequency Domain) Measurements . . . . .	35
Configuring the Measurement System . . . . .	35
Setting the BTS. . . . .	36
Measurement Procedure. . . . .	36
Waveform (Time Domain) Measurements . . . . .	42
Configuring the Measurement System . . . . .	42
Measurement Procedure. . . . .	43
Using the Waveform Measurement to Set Up Triggering (for burst signals) . . . . .	48
Power Stat CCDF Measurements . . . . .	49
Measurement Procedure. . . . .	49
SCPI Control of the PSA Options 122 and 140 Wideband IF . . . . .	52
What does Option 122 or 140 Do? . . . . .	52
Acquiring Time Data. . . . .	52
Making Deep Data Captures . . . . .	55
Reducing Noise with Hardware Time Averaging . . . . .	56
Turning Alignments Off . . . . .	58
Using LAN Ports with Visual Basic 6.0. . . . .	60

## 3. Key Reference

Instrument Front Panel Highlights . . . . .	70
Selected PSA Front-Panel Features. . . . .	71
Front Panel Keys . . . . .	72
FREQUENCY Channel Key Menu . . . . .	72
Span X Scale Key Menu . . . . .	72
MEASURE Key Menu. . . . .	73
Meas Control Key Menu . . . . .	73
Mode Setup Key Menu . . . . .	76

---

# Contents

Trigger Key Menu . . . . .	78
Spectrum (Frequency Domain) Keys . . . . .	81
Meas Setup Key Menu . . . . .	81
View/Trace Key Menu . . . . .	90
SPAN X Scale Key Menu . . . . .	91
AMPLITUDE Y Scale Key Menu . . . . .	92
Display Key Menu . . . . .	92
Marker Key Menu . . . . .	92
Peak Search Key . . . . .	93
Waveform (Time Domain) Keys . . . . .	94
Measurement Setup Key Menu . . . . .	94
Trace/View Key Menu . . . . .	100
SPAN X Scale Key Menu . . . . .	102
AMPLITUDE Y Scale Key Menu . . . . .	103
Display Key Menu . . . . .	103
Marker Key Menu . . . . .	104
Peak Search Key . . . . .	104
Power Stat CCDF Keys . . . . .	105
Meas Setup Key Menu . . . . .	105

## 4. Programming Commands

Programming Command Compatibility	
Across Model Numbers and Across Modes . . . . .	111
Across PSA Modes: Command Subsystem Similarities . . . . .	111
Across PSA Modes: Specific Command Differences . . . . .	113
Using Applications in PSA Series vs. VSA E4406A . . . . .	114
Using the Status Registers . . . . .	116
What Status Registers Are . . . . .	116
How to Use the Status Registers . . . . .	119
Using a Status Register . . . . .	120
Using the Service Request (SRQ) Method . . . . .	121
Status Byte Register . . . . .	126
Standard Event Status Register . . . . .	129
Operation and Questionable Status Registers . . . . .	131
CALCulate Subsystem . . . . .	132
Power Statistics CCDF—Store Reference . . . . .	132
Calculate/Compress Trace Data Query . . . . .	132
Calculate Peaks of Trace Data . . . . .	142
CALCulate:MARKers Subsystem . . . . .	143
CALibration Subsystem . . . . .	154
Wideband IF External Corrections . . . . .	154
Wideband IF External Correction File Selection . . . . .	154
CONFigure Subsystem . . . . .	155
Configure the Selected Measurement . . . . .	155
Configure Query . . . . .	155
DISPlay Subsystem . . . . .	156
Power Statistics CCDF - X-Axis Scale/Div . . . . .	156
Select Display Format . . . . .	156
Select Display Format . . . . .	157

Spectrum - Y-Axis Scale/Div	157
Spectrum - Y-Axis Reference Level	158
Turn a Trace Display On/Off	159
Waveform - Y-Axis Scale/Div	163
Waveform - Y-Axis Reference Level	164
FETCh Subsystem	165
Fetch the Current Measurement Results	165
Query Deep Capture Data (Remote Command Only)	165
FORMat Subsystem	167
Byte Order	167
Numeric Data Format	167
INITiate Subsystem	169
Take New Data Acquisition for Selected Measurement	169
Continuous or Single Measurements	169
Take New Data Acquisitions	170
Restart the Measurement	171
Capture Time Data	171
INSTRument Subsystem	172
Catalog Query	172
Select Application by Number	172
Select Application	173
MEASure Group of Commands	175
Command Interactions: MEASure, CONFigure, FETCh, INITiate and READ	175
Power Statistics CCDF Measurement	180
Spectrum (Frequency Domain) Measurement	182
Waveform (Time Domain) Measurement	185
SENSE Subsystem	187
Power Stat CCDF Measurement	187
Correction for RF Port External Attenuation	194
Select the Input Signal	194
Select Live or Recorded Input Data	195
RF Power Commands	195
Spectrum (Frequency-Domain) Measurement	197
Time Capture Commands	216
Waveform (Time-Domain) Measurement	218
TRIGger Subsystem	232
Automatic Trigger Control	232
Automatic Trigger Time	232
External Trigger Delay	233
External Trigger Level	233
External Trigger Slope	234
Frame Trigger Adjust	234
Frame Trigger Period	234
Frame Trigger Sync Source	235
Frame Trigger Synchronization Offset	235
Trigger Holdoff	236
Video (IF) Trigger Delay	236
Video (IF) Trigger Level	236
Video (IF) Trigger Slope	237

---

# Contents

RF Burst Trigger Delay .....	237
RF Burst Trigger Level .....	237
RF Burst Trigger Slope .....	238

## 5. Concepts

Spectrum (Frequency Domain) Measurement Concepts .....	240
Purpose .....	240
Measurement Method .....	240
Troubleshooting Hints .....	240
Waveform (Time Domain) Measurement Concepts .....	241
Purpose .....	241
Measurement Method .....	241
Power Stat CCDF Measurement Concepts .....	242
Purpose .....	242
Measurement Method .....	242
Troubleshooting Hints .....	242
PSA Options 122 and 140 Wideband Digitizer .....	243
Trigger System Differences .....	243
Fast Hardware Averaging .....	246
Deep Data Captures .....	247
Channel Filter .....	248
Available Dynamic Range .....	248
Other Sources of Measurement Information .....	250
Instrument Updates at <a href="http://www.agilent.com">www.agilent.com</a> .....	250

## 6. Menu Maps

Basic Measurement Key Flow .....	252
----------------------------------	-----

---

# List of Commands

:CALCulate:CLIMits:FAIL? .....	179
:CALCulate:DATA<n>:COMPRESS? BLOCK   CFIT   MAXimum   MINimum   MEAN   DMEan   RMS   SAMPLE   SDEVIation   PPHase [,<soffset>[,<length>[,<roffset>[,<rlimit>]]]] .....	132
:CALCulate:DATA<n>:PEAKs? <threshold>,<excursion>[,AMPLitude   FREQuency   TIME] ...	142
:CALCulate:<measurement>:MARKer:AOFF .....	144
:CALCulate:<measurement>:MARKer[1] 2 3 4:FUNCTion:RESult? .....	144
:CALCulate:<measurement>:MARKer[1] 2 3 4:MAXimum .....	144
:CALCulate:<measurement>:MARKer[1] 2 3 4:MINimum .....	145
:CALCulate:<measurement>:MARKer[1] 2 3 4:MODE POSition   DELTA .....	145
:CALCulate:<measurement>:MARKer[1] 2 3 4:MODE POSition   DELTA   RMSDegree   RMSRadian   RFM   RMSJitter   OFF .....	145
:CALCulate:<measurement>:MARKer[1] 2 3 4:MODE? .....	145
:CALCulate:<measurement>:MARKer[1] 2 3 4:TRACe <trace_name> .....	147
:CALCulate:<measurement>:MARKer[1] 2 3 4:TRACe? .....	147
:CALCulate:<measurement>:MARKer[1] 2 3 4:X <param> .....	151
:CALCulate:<measurement>:MARKer[1] 2 3 4:X:POSition <integer> .....	152
:CALCulate:<measurement>:MARKer[1] 2 3 4:X:POSition? .....	152
:CALCulate:<measurement>:MARKer[1] 2 3 4:X? .....	151
:CALCulate:<measurement>:MARKer[1] 2 3 4:Y? .....	152
:CALCulate:<measurement>:MARKer[1] 2 3 4[:STATe] OFF   ON   0   1 .....	147
:CALCulate:<measurement>:MARKer[1] 2 3 4[:STATe]? .....	147
:CALibration:WBIF:ECORrection OFF   ON   0   1 .....	154
:CALibration:WBIF:ECORrection:FILE <file name> .....	154
:CALibration:WBIF:ECORrection:FILE? .....	154
:CALibration:WBIF:ECORrection? .....	154
:CONFigure:CCDF .....	180
:CONFigure:SPECTrum .....	182
:CONFigure:WAVEform .....	185
:CONFigure:<measurement> .....	155
:CONFigure? .....	155
:CONFigure? .....	179

---

# List of Commands

:DISPlay:CCDF:WINDow:TRACe:X[:SCALe]:PDIVision <rel_ampl> . . . . .	156
:DISPlay:CCDF:WINDow:TRACe:X[:SCALe]:PDIVision? . . . . .	156
:DISPlay:FORMat:TILE . . . . .	156
:DISPlay:FORMat:ZOOM . . . . .	157
:DISPlay:SPECtrum[n]:WINDow[m]:TRACe:Y[:SCALe]:PDIVision <power> . . . . .	157
:DISPlay:SPECtrum[n]:WINDow[m]:TRACe:Y[:SCALe]:PDIVision? . . . . .	157
:DISPlay:SPECtrum[n]:WINDow[m]:TRACe:Y[:SCALe]:RLEVel <power> . . . . .	158
:DISPlay:SPECtrum[n]:WINDow[m]:TRACe:Y[:SCALe]:RLEVel? . . . . .	158
:DISPlay:TRACe[n][:STATe] OFF   ON   0   1 . . . . .	159
:DISPlay:TRACe[n][:STATe]? . . . . .	159
:DISPlay:WAVEform[n]:WINDow[m]:TRACe:Y[:SCALe]:PDIVision <power> . . . . .	163
:DISPlay:WAVEform[n]:WINDow[m]:TRACe:Y[:SCALe]:PDIVision? . . . . .	163
:DISPlay:WAVEform[n]:WINDow[m]:TRACe:Y[:SCALe]:RLEVel <power> . . . . .	164
:DISPlay:WAVEform[n]:WINDow[m]:TRACe:Y[:SCALe]:RLEVel? . . . . .	164
:FETCh:CCDF[n]? . . . . .	180
:FETCh:SPECtrum[n]? . . . . .	182
:FETCh:TCAPture? . . . . .	165
:FETCh:WAVEform[n]? . . . . .	185
:FETCh:<measurement>[n]? . . . . .	165
:FORMat:BORDER NORMal   SWAPped . . . . .	167
:FORMat:BORDER? . . . . .	167
:FORMat[:DATA] ASCii   REAL,32   REAL,64 . . . . .	167
:FORMat[:DATA]? . . . . .	167
:FORMat[:TRACe][:DATA] ASCii   INTeger,16   INTeger,32   REAL,32   REAL,64   UINTeGer,16 . .	167
:FORMat[:TRACe][:DATA] ASCii   REAL[,32] . . . . .	167
:FORMat[:TRACe][:DATA]? . . . . .	167
:FORMat[:TRACe][:DATA]? . . . . .	167
:INITiate:CCDF . . . . .	180
:INITiate:CONTinuous OFF   ON   0   1 . . . . .	169
:INITiate:CONTinuous? . . . . .	169
:INITiate:REStart . . . . .	171



---

# List of Commands

:INITiate:SPECtrum	182
:INITiate:TCAPture	171
:INITiate:WAVEform	185
:INITiate:<measurement>	169
:INITiate[:IMMediate]	170
:INSTrument:CATalog?	172
:INSTrument:NSElect <integer>	172
:INSTrument:NSElect?	172
:INSTrument[:SElect] SA   PNOISE   BASIC   CDMA   CDMA2K   EDGE GSM   NADC PDC   WCDMA   CDMA1XEV   NFIGURE   WLAN   MRECEIVE   TDSCDMA   TDDEMOD   EMC   DEMODIULATION	173
:INSTrument[:SElect]?	173
:MEASure:CCDF[n]?	180
:MEASure:SPECtrum[n]?	182
:MEASure:WAVEform[n]?	185
:READ:CCDF[n]?	180
:READ:SPECtrum[n]?	182
:READ:WAVEform[n]?	185
:TRIGger[:SEquence]:AUTO:STATe OFF   ON   0   1	232
:TRIGger[:SEquence]:AUTO:STATe?	232
:TRIGger[:SEquence]:AUTO[:TIME] <time>	232
:TRIGger[:SEquence]:AUTO[:TIME]?	232
:TRIGger[:SEquence]:EXTernal[1]   2:DELay <time>	233
:TRIGger[:SEquence]:EXTernal[1]   2:DELay?	233
:TRIGger[:SEquence]:EXTernal[1]   2:LEVel <voltage>	233
:TRIGger[:SEquence]:EXTernal[1]   2:LEVel?	233
:TRIGger[:SEquence]:EXTernal[1]   2:SLOPe NEGative   POSitive	234
:TRIGger[:SEquence]:EXTernal[1]   2:SLOPe?	234
:TRIGger[:SEquence]:FRAME:ADJust <time>	234
:TRIGger[:SEquence]:FRAME:PERiod <time>	234
:TRIGger[:SEquence]:FRAME:PERiod?	234
:TRIGger[:SEquence]:FRAME:SYNC EXTFront   EXTrear   OFF	235

---

# List of Commands

:TRIGger[:SEquence]:FRAME:SYNC:OFFSet <time> .....	235
:TRIGger[:SEquence]:FRAME:SYNC:OFFSet? .....	235
:TRIGger[:SEquence]:FRAME:SYNC? .....	235
:TRIGger[:SEquence]:HOLDoff <time> .....	236
:TRIGger[:SEquence]:HOLDoff? .....	236
:TRIGger[:SEquence]:IF:DELay <time> .....	236
:TRIGger[:SEquence]:IF:DELay? .....	236
:TRIGger[:SEquence]:IF:LEVel <ampl> .....	236
:TRIGger[:SEquence]:IF:LEVel? .....	236
:TRIGger[:SEquence]:IF:SLOPe NEGative   POSitive .....	237
:TRIGger[:SEquence]:IF:SLOPe? .....	237
:TRIGger[:SEquence]:RFBurst:DELay <time> .....	237
:TRIGger[:SEquence]:RFBurst:DELay? .....	237
:TRIGger[:SEquence]:RFBurst:LEVel <rel_power> .....	237
:TRIGger[:SEquence]:RFBurst:LEVel? .....	237
:TRIGger[:SEquence]:RFBurst:SLOPe NEGative   POSitive .....	238
:TRIGger[:SEquence]:RFBurst:SLOPe? .....	238
[:CALCulate]:CCDF:STORe:REFerence .....	132
[:SENSe]:CCDF:BANDwidth   BWIDth<freq> .....	188
[:SENSe]:CCDF:BANDwidth   BWIDth? .....	188
[:SENSe]:CCDF:BSIZe <integer> .....	190
[:SENSe]:CCDF:BSIZe? .....	190
[:SENSe]:CCDF:GAUSsian[:STATe] OFF   ON   0   1 .....	187
[:SENSe]:CCDF:GAUSsian[:STATe]? .....	187
[:SENSe]:CCDF:REFerence[:STATe] OFF   ON   0   1 .....	187
[:SENSe]:CCDF:REFerence[:STATe]? .....	187
[:SENSe]:CCDF:RESTore:DEFaults .....	193
[:SENSe]:CCDF:SRATe <freq> .....	190
[:SENSe]:CCDF:SRATe? .....	190
[:SENSe]:CCDF:SWEep:TIME<time> .....	188
[:SENSe]:CCDF:SWEep:TIME? .....	188

---

# List of Commands

[[:SENSe]:CCDF:TRIGger:INTerpolate OFF ON 0 1	193
[[:SENSe]:CCDF:TRIGger:INTerpolate?	193
[[:SENSe]:CCDF:TRIGger:SOURce IMMEDIATE IF EXternal[1] EXternal2 FRAME LINE	193
[[:SENSe]:CCDF:TRIGger:SOURce?	193
[[:SENSe]:CCDF:WBIF:ADCCorrect OFF ON 0 1	192
[[:SENSe]:CCDF:WBIF:ADCCorrect?	192
[[:SENSe]:CCDF:WBIF:ADC:DITHer OFF ON 0 1	192
[[:SENSe]:CCDF:WBIF:ADC:DITHer?	192
[[:SENSe]:CCDF:WBIF:FILTer:ALPHa <value>	189
[[:SENSe]:CCDF:WBIF:FILTer:ALPHa?	189
[[:SENSe]:CCDF:WBIF:FILTer:BANDwidth BWIDth <value>	190
[[:SENSe]:CCDF:WBIF:FILTer:BANDwidth BWIDth?	190
[[:SENSe]:CCDF:WBIF:FILTer[:TYPE] NONE RCOSine RRCosine NYQuist RNYQuist GAUSsian	189
[[:SENSe]:CCDF:WBIF:FILTer[:TYPE]?	189
[[:SENSe]:CCDF:WBIF:FLATness OFF ON 0 1	192
[[:SENSe]:CCDF:WBIF:FLATness?	192
[[:SENSe]:CCDF:WBIF:IFGain<integer>	188
[[:SENSe]:CCDF:WBIF:IFGain?	188
[[:SENSe]:CORRection[:RF]:LOSS <rel_power>	194
[[:SENSe]:CORRection[:RF]:LOSS?	194
[[:SENSe]:FEED RF AREFERENCE IFALign WBALign	194
[[:SENSe]:FEED:DATA INPut RECOreded	195
[[:SENSe]:FEED:DATA?	195
[[:SENSe]:FEED?	194
[[:SENSe]:POWer[:RF]:ATTenuation <rel_power>	195
[[:SENSe]:POWer[:RF]:ATTenuation?	195
[[:SENSe]:POWer[:RF]:RANGe:AUTO OFF ON 0 1	195
[[:SENSe]:POWer[:RF]:RANGe:AUTO?	196
[[:SENSe]:POWer[:RF]:RANGe[:UPPer] <power>	196
[[:SENSe]:POWer[:RF]:RANGe[:UPPer]?	196

---

# List of Commands

[[:SENSe]:SPECTrum:ACQuisition:PACKing AUTO LONG MEDIUm SHORt . . . . .	197
[[:SENSe]:SPECTrum:ACQuisition:PACKing? . . . . .	197
[[:SENSe]:SPECTrum:ADC:DITHer[:STATe] AUTO ON OFF 2 1 0 . . . . .	197
[[:SENSe]:SPECTrum:ADC:DITHer[:STATe]? . . . . .	197
[[:SENSe]:SPECTrum:ADC:RANGe AUTO APEak APLock NONE P0 P6 P12 P18 . . . . .	198
[[:SENSe]:SPECTrum:ADC:RANGe? . . . . .	198
[[:SENSe]:SPECTrum:AFILter:AUTO OFF ON 0 1 . . . . .	200
[[:SENSe]:SPECTrum:AFILter:AUTO? . . . . .	200
[[:SENSe]:SPECTrum:AVERAge:CLEAr . . . . .	200
[[:SENSe]:SPECTrum:AVERAge:COUNT <integer> . . . . .	200
[[:SENSe]:SPECTrum:AVERAge:COUNT? . . . . .	200
[[:SENSe]:SPECTrum:AVERAge:TACount <integer> . . . . .	201
[[:SENSe]:SPECTrum:AVERAge:TACount? . . . . .	201
[[:SENSe]:SPECTrum:AVERAge:TCONtrol EXPONential REPeat . . . . .	202
[[:SENSe]:SPECTrum:AVERAge:TCONtrol? . . . . .	202
[[:SENSe]:SPECTrum:AVERAge:TYPE LOG MAXimum MINimum RMS SCALAr . . . . .	202
[[:SENSe]:SPECTrum:AVERAge:TYPE? . . . . .	202
[[:SENSe]:SPECTrum:AVERAge[:STATe] OFF ON 0 1 . . . . .	201
[[:SENSe]:SPECTrum:AVERAge[:STATe]? . . . . .	201
[[:SENSe]:SPECTrum:BANDwidth BWIDth:IF:AUTO OFF ON 0 1 . . . . .	203
[[:SENSe]:SPECTrum:BANDwidth BWIDth:IF:AUTO? . . . . .	203
[[:SENSe]:SPECTrum:BANDwidth BWIDth:IF:FLATness OFF ON 0 1 . . . . .	203
[[:SENSe]:SPECTrum:BANDwidth BWIDth:IF:FLATness? . . . . .	203
[[:SENSe]:SPECTrum:BANDwidth BWIDth:PADC OFF ON 0 1 . . . . .	204
[[:SENSe]:SPECTrum:BANDwidth BWIDth:PADC? . . . . .	204
[[:SENSe]:SPECTrum:BANDwidth BWIDth:PFFT:TYPE FLAT GAUSSian . . . . .	204
[[:SENSe]:SPECTrum:BANDwidth BWIDth:PFFT:TYPE? . . . . .	204
[[:SENSe]:SPECTrum:BANDwidth BWIDth:PFFT[:SIZE] <freq> . . . . .	204
[[:SENSe]:SPECTrum:BANDwidth BWIDth:PFFT[:SIZE]? . . . . .	204
[[:SENSe]:SPECTrum:BANDwidth BWIDth[:RESolution] <freq> . . . . .	205
[[:SENSe]:SPECTrum:BANDwidth BWIDth[:RESolution]:AUTO OFF ON 0 1 . . . . .	205

---

## List of Commands

[[:SENSe]:SPECTrum: BANDwidth   BWIDth[:RESolution]:AUTO? . . . . .	205
[[:SENSe]:SPECTrum: BANDwidth   BWIDth[:RESolution]? . . . . .	205
[[:SENSe]:SPECTrum: DECimate[:FACTor] <integer> . . . . .	206
[[:SENSe]:SPECTrum: DECimate[:FACTor]? . . . . .	206
[[:SENSe]:SPECTrum: FFT: LENGth <integer> . . . . .	206
[[:SENSe]:SPECTrum: FFT: LENGth: AUTO OFF   ON   0   1 . . . . .	207
[[:SENSe]:SPECTrum: FFT: LENGth: AUTO? . . . . .	207
[[:SENSe]:SPECTrum: FFT: LENGth? . . . . .	206
[[:SENSe]:SPECTrum: FFT: RBWPoints <real> . . . . .	207
[[:SENSe]:SPECTrum: FFT: RBWPoints? . . . . .	207
[[:SENSe]:SPECTrum: FFT: WINDow: DELay <real> . . . . .	208
[[:SENSe]:SPECTrum: FFT: WINDow: DELay? . . . . .	208
[[:SENSe]:SPECTrum: FFT: WINDow: LENGth <integer> . . . . .	208
[[:SENSe]:SPECTrum: FFT: WINDow: LENGth? . . . . .	208
[[:SENSe]:SPECTrum: FFT: WINDow[:TYPE] BH4Tap   BLACKman   FLATtop   GAUSSian   HAM- Ming   HANNing   KB70   KB90   KB110   UNIFORM . . . . .	208
[[:SENSe]:SPECTrum: FFT: WINDow[:TYPE]? . . . . .	208
[[:SENSe]:SPECTrum: FREQuency: SPAN <freq> . . . . .	209
[[:SENSe]:SPECTrum: FREQuency: SPAN? . . . . .	209
[[:SENSe]:SPECTrum: IFGain <numeric> . . . . .	210
[[:SENSe]:SPECTrum: IFGain? . . . . .	210
[[:SENSe]:SPECTrum: IFPath NARRow   WIDE . . . . .	210
[[:SENSe]:SPECTrum: IFPath? . . . . .	210
[[:SENSe]:SPECTrum: SWEep: TIME: AUTO OFF   ON   0   1 . . . . .	211
[[:SENSe]:SPECTrum: SWEep: TIME: AUTO . . . . .	211
[[:SENSe]:SPECTrum: SWEep: TIME? . . . . .	210
[[:SENSe]:SPECTrum: SWEep: TIME[:VALue] <time> . . . . .	210
[[:SENSe]:SPECTrum: TRIGger: SOURce EXTernal[1]   EXTernal2   FRAME   IF   LINE   IMMEdi- ate   RFBurst . . . . .	211
[[:SENSe]:SPECTrum: TRIGger: SOURce? . . . . .	211
[[:SENSe]:SPECTrum: WBIF: ADCCorrect OFF   ON   0   1 . . . . .	212
[[:SENSe]:SPECTrum: WBIF: ADCCorrect? . . . . .	212

---

# List of Commands

[[:SENSe]:SPECTrum:WBIF:ADC:DITHer OFF ON 0 1	.212
[[:SENSe]:SPECTrum:WBIF:ADC:DITHer?	.212
[[:SENSe]:SPECTrum:WBIF:FILTer:ALPHa <numeric>	.214
[[:SENSe]:SPECTrum:WBIF:FILTer:ALPHa?	.214
[[:SENSe]:SPECTrum:WBIF:FILTer:BANDwidth BWIDth <numeric>	.214
[[:SENSe]:SPECTrum:WBIF:FILTer:BANDwidth BWIDth?	.214
[[:SENSe]:SPECTrum:WBIF:FILTer[:TYPE] NONE GAUSS- ian NYQuist RNYQuist RCOSine RRCosine	.214
[[:SENSe]:SPECTrum:WBIF:FILTer[:TYPE]?	.214
[[:SENSe]:SPECTrum:WBIF:FLATness OFF ON 0 1	.215
[[:SENSe]:SPECTrum:WBIF:FLATness?	.215
[[:SENSe]:TCAPture:CRECord?	.216
[[:SENSe]:TCAPture:FRECORD <integer>	.216
[[:SENSe]:TCAPture:FRECORD?	.216
[[:SENSe]:TCAPture:LRECORD <integer>	.216
[[:SENSe]:TCAPture:LRECORD?	.216
[[:SENSe]:TCAPture:NRECORD <integer>	.216
[[:SENSe]:TCAPture:NRECORD?	.216
[[:SENSe]:TCAPture:TIME <numeric>	.217
[[:SENSe]:TCAPture:TIME?	.217
[[:SENSe]:WAVEform:ACQuisition:PACKing AUTO LONG MEDIum SHORT	.218
[[:SENSe]:WAVEform:ACQuisition:PACKing?	.218
[[:SENSe]:WAVEform:ADC:DITHer[:STATe] AUTO ON OFF 2 1 0	.218
[[:SENSe]:WAVEform:ADC:DITHer[:STATe]?	.218
[[:SENSe]:WAVEform:ADC:FILTer[:STATe] OFF ON 0 1	.218
[[:SENSe]:WAVEform:ADC:FILTer[:STATe]?	.218
[[:SENSe]:WAVEform:ADC:RANGe AUTO APEak APLock GROund NONE P0 P6 P12 P18	.219
[[:SENSe]:WAVEform:ADC:RANGe?	.219
[[:SENSe]:WAVEform:AFILter: F80 F40 F36	.220
[[:SENSe]:WAVEform:AFILter:AUTO OFF ON 0 1	.220
[[:SENSe]:WAVEform:AFILter:AUTO?	.220

---

# List of Commands

[[:SENSe]:WAVeform:AFILter? . . . . .	220
[[:SENSe]:WAVeform:APERture? . . . . .	220
[[:SENSe]:WAVeform:AVERage:COUNT <integer> . . . . .	221
[[:SENSe]:WAVeform:AVERage:COUNT? . . . . .	221
[[:SENSe]:WAVeform:AVERage:TACount <integer> . . . . .	221
[[:SENSe]:WAVeform:AVERage:TACount? . . . . .	221
[[:SENSe]:WAVeform:AVERage:TCONtrol EXPonential   REPeat . . . . .	222
[[:SENSe]:WAVeform:AVERage:TCONtrol? . . . . .	222
[[:SENSe]:WAVeform:AVERage:TYPE LOG   MAXimum   MINimum   RMS   SCALar . . . . .	222
[[:SENSe]:WAVeform:AVERage:TYPE? . . . . .	222
[[:SENSe]:WAVeform:AVERage[:STATe] OFF   ON   0   1 . . . . .	221
[[:SENSe]:WAVeform:AVERage[:STATe]? . . . . .	221
[[:SENSe]:WAVeform:BANDwidth[:RESolution]:ACTual? . . . . .	224
[[:SENSe]:WAVeform:BANDwidth   BWIDth[:RESolution] <freq> . . . . .	223
[[:SENSe]:WAVeform:BANDwidth   BWIDth[:RESolution]:TYPE FLATtop   GAUSSian . . . . .	224
[[:SENSe]:WAVeform:BANDwidth   BWIDth[:RESolution]:TYPE? . . . . .	224
[[:SENSe]:WAVeform:BANDwidth   BWIDth[:RESolution]? . . . . .	223
[[:SENSe]:WAVeform:BSIZE? . . . . .	224
[[:SENSe]:WAVeform:DECimate:STATe OFF   ON   0   1 . . . . .	225
[[:SENSe]:WAVeform:DECimate:STATe? . . . . .	225
[[:SENSe]:WAVeform:DECimate[:FACTor] <integer> . . . . .	225
[[:SENSe]:WAVeform:DECimate[:FACTor]? . . . . .	225
[[:SENSe]:WAVeform:IFGain <numeric> . . . . .	225
[[:SENSe]:WAVeform:IFGain? . . . . .	225
[[:SENSe]:WAVeform:IFPath NARRow   WIDE . . . . .	226
[[:SENSe]:WAVeform:IFPath? . . . . .	226
[[:SENSe]:WAVeform:NCPTrace OFF   ON   0   1 . . . . .	226
[[:SENSe]:WAVeform:NCPTrace? . . . . .	226
[[:SENSe]:WAVeform:SRATE <freq> . . . . .	226
[[:SENSe]:WAVeform:SRATE? . . . . .	226
[[:SENSe]:WAVeform:SWEep:TIME <time> . . . . .	227

---

# List of Commands

[:SENSe]:WAVeform:SWEEp:TIME? . . . . .	.227
[:SENSe]:WAVeform:TRIGger:EOFFset? . . . . .	.227
[:SENSe]:WAVeform:TRIGger:INTerpolation OFF ON 0 1 . . . . .	.228
[:SENSe]:WAVeform:TRIGger:INTerpolation? . . . . .	.228
[:SENSe]:WAVeform:TRIGger:SOURce EXTernal[1]   EXTernal2   FRAME   IF   IMMEDIATE   LINE   RFBurst . . . . .	.228
[:SENSe]:WAVeform:TRIGger:SOURce? . . . . .	.228
[:SENSe]:WAVeform:WBIF:ADCCorrect OFF ON 0 1 . . . . .	.229
[:SENSe]:WAVeform:WBIF:ADCCorrect? . . . . .	.229
[:SENSe]:WAVeform:WBIF:ADC:DITHer OFF ON 0 1 . . . . .	.229
[:SENSe]:WAVeform:WBIF:ADC:DITHer? . . . . .	.229
[:SENSe]:WAVeform:WBIF:FILTer:ALPHa <numeric> . . . . .	.230
[:SENSe]:WAVeform:WBIF:FILTer:ALPHa? . . . . .	.230
[:SENSe]:WAVeform:WBIF:FILTer:BANDwidth   BWIDth <numeric> . . . . .	.230
[:SENSe]:WAVeform:WBIF:FILTer:BANDwidth   BWIDth? . . . . .	.230
[:SENSe]:WAVeform:WBIF:FILTer[:TYPE] NONE   GAUSS- ian   NYQuist   RNYQuist   RCOSine   RRCosine . . . . .	.230
[:SENSe]:WAVeform:WBIF:FILTer[:TYPE]? . . . . .	.230
[:SENSe]:WAVeform:WBIF:FLATness OFF ON 0 1 . . . . .	.231
[:SENSe]:WAVeform:WBIF:FLATness? . . . . .	.231



---

# 1 Introduction

This chapter provides information on using the Agilent PSA Series Spectrum Analyzers with the Basic mode personality. The Basic mode personality is standard on all instruments with Options B7J, 122, and 140.

---

## What Does Basic Mode Do?

Basic Mode makes frequency domain, time domain, and power statistics (CCDF) measurements, usually using an alternate hardware path. Frequency domain and time domain measurements can be used to output I/Q data results when measuring complex modulated digital signals. The power statistics measurement can be used to characterize the higher level power statistics of a digitally modulated signal.

- **Spectrum Measurement (Frequency Domain)**

This measurement is comparable to a precision microwave spectrum analyzer measurement that also provides demodulated I/Q data for individual I and Q amplitude data pairs. See [“Spectrum \(Frequency Domain\) Measurements” on page 35.](#)

- **Waveform Measurement (Time Domain)**

This measurement is comparable to a precision vector signal analyzer measurement that also provides demodulated I/Q data for individual magnitude and phase analysis. See [“Waveform \(Time Domain\) Measurements” on page 42.](#)

- **Power Stat Measurement (CCDF)**

Power Complimentary Cumulative Function (CCDF) curves characterize the higher level power statistics of a digitally modulated signal. The results are displayed graphically, as well as in a “Metrics” window. See [“Power Stat CCDF Measurements” on page 49.](#)

The following optional alternate hardware and measurement personalities are typically used with Basic Mode:

- **Option B7J** provides an alternate attenuator that switches electronically. It has a maximum of 40 dB in 1 dB steps. (Standard is 70 dB maximum attenuation in 2 dB steps.). This hardware may be accessed from within Basic Mode (narrowband IF path only).
- **Option 122** provides an alternate wideband digital IF signal path with a maximum bandwidth of 80 MHz. This hardware may be accessed from within Basic Mode and Option 241, Flexible Digital Modulation Analysis Mode.
- **Option 123** allows you to bypass the tuned filter at the input of the spectrum analyzer when making measurements in the 3 to 50 GHz range. This improves the sensitivity and increases the available measurement dynamic range. This option is recommended when measuring wideband signals above 3 GHz.
- **Option 140** provides an alternate wideband digital IF signal path with a maximum bandwidth of 40 MHz. This hardware may be accessed from within Basic Mode and Option 241, Flexible Digital Modulation Analysis Mode.

---

## Option B7J: Digital Demodulation Hardware

Option B7J is required for many of the optional measurement personalities. The option includes the Basic Mode measurements in addition to the optional hardware. Basic Mode includes two generic measurements that can be used to output I/Q data results when measuring complex modulated digital signals. See the descriptions in [“What Does Basic Mode Do?” on page 18](#)

The Option B7J hardware does the fast switching necessary to accommodate the complicated multiple-sweep, averaged measurements required for digital communication systems testing. The hardware is specified for measurements up to a maximum of 3 GHz and works with many different measurement personalities. These optional software personalities are accessed using the **MODE** key.

You may have separately ordered additional measurement personalities to be used with the Option B7J hardware. See [“Installing Optional Measurement Personalities” on page 21](#) to install an optional personality.

---

## Options 122 and 140: Wideband Digitizer Hardware

Option 122 hardware enables up to 80 MHz of capture bandwidth and Option 140 enables up to 40 MHz of capture bandwidth. Basic Mode software is provided to access the wideband hardware.

There are couplings and interactions when using the Option 122 or 140 with other options and hardware.

- Options 122 and 140 are only available for use with the PSA Series E4440A, E4443A, E4445A, E4446A, and E4448A spectrum analyzers.
- The wideband functionality of Option 122 or 140 is only available in Basic, Flexible Digital Modulation Analysis, and WLAN personality modes. It cannot be accessed from the core Spectrum Analysis Mode or other optional personality modes.
- If the wideband hardware (Option 122 or 140) is installed, Basic Mode will always make measurements above 3 GHz using the wideband path. The standard “narrowband” path is not available in Basic Mode above 3 GHz.
- Option B7J (1 dB electronic attenuator for digital communications) is not required for the wideband options (122 and 140).
- If Option 122 or 140 wideband hardware is installed, but Option B7J is *not* installed, then the wideband input path will be used for all measurements in Basic Mode. Since the standard “narrowband” path is not available in Basic Mode without Option B7J, only the Option 122 or 140 specifications will apply.
- The Option 1DS or Option 110 preamp cannot be used in Basic Mode with Option 122 or 140.
- Option 123 (input preselector bypass) will work with Option 122 or 140, as well as Option 241, Flexible Digital Modulation Analysis Mode, Option 217, WLAN mode, and Option 233, Measuring Receiver mode (requires firmware version A.07.04 or greater).

External calibration capability can be used with Option 122 or 140 to improve accuracy. This is available using:

- Option 235: PC-based external calibration software for use with Option 122 or 140 on the PSA Series. This option applies the correction real-time using DSP hardware.
- Agilent 89601A Vector Signal Analysis Software.

---

## Installing Optional Measurement Personalities

When you install a measurement personality, you need to follow a three step process:

1. Determine whether your memory capacity is sufficient to contain all the options you want to load. If not, decide which options you want to install now, and consider upgrading your memory. Details follow in [“Do You Have Enough Memory to Load All Your Personality Options?”](#) on page 21.
2. Install the measurement personality firmware into the instrument memory. Details follow in [“Loading an Optional Measurement Personality”](#) on page 26.
3. Enter a license key that activates the measurement personality. Details follow in [“Obtaining and Installing a License Key”](#) on page 27.

Adding measurement personalities requires the purchase of an upgrade kit for the desired option. The upgrade kit contains the measurement personality firmware and an entitlement certificate that is used to generate a license key from the internet website. A separate license key is required for each option on a specific instrument serial number and host ID.

For the latest information on Agilent Spectrum Analyzer options and upgrade kits, visit the following web location:

[http://www.agilent.com/find/sa\\_upgrades](http://www.agilent.com/find/sa_upgrades)

### Do You Have Enough Memory to Load All Your Personality Options?

If you do not have memory limitations then you can skip ahead to the next section [“Loading an Optional Measurement Personality”](#) on page 26. If after installing your options you get error messages relating to memory issues, you can return to this section to learn more about how to optimize your configuration.

If you have 64 MBytes of memory installed in your instrument, you should have enough memory to install at least four optional personalities, with plenty of memory for data and states.

The optional measurement personalities require different amounts of memory. So the number of personalities that you can load varies. This is also impacted by how much data you need to save. If you are having memory errors you must swap the applications in or out of memory as needed. If you only have 48 MBytes of memory, you can upgrade your

hardware to 64 MBytes.

Additional memory can be added to any PSA Series analyzer by installing Option 115. With this option installed, you can install all currently available measurement personalities in your analyzer and still have memory space to store more state and trace files than would otherwise be possible.

To see the size of your installed memory for PSA Series Spectrum Analyzers:

1. Ensure that the spectrum analyzer is in spectrum analyzer mode because this can affect the screen size.
2. Press **System, Show System**. Under Options look for 115.
3. Press **System, More, Show Hdw**.
4. Read Flash Memory size in the table.

PSA Flash Memory Size	Available Memory Without Option B7J and Option 122 or 140	Available Memory With Option B7J and Option 122 or 140
64 Mbytes	32.5 MBytes	30.0 MBytes
48 Mbytes	16.9 MBytes	14.3 MBytes

PSA Compact Flash Memory Size	Available Additional Memory for Measurement Personalities
512 Mbytes (Opt. 115)	512 MBytes

If you have 48 MBytes of memory, and you want to install more than 3 optional personalities, you may need to manage your memory resources. The following section, “[How to Predict Your Memory Requirements](#)” on page 23, will help you decide how to configure your installed options to provide optimal operation.

### How to Predict Your Memory Requirements

If you plan to install many optional personalities, you should review your memory requirements, so you can determine whether you have enough memory (unless you have a PSA Series with Option 115). There is an Agilent “Memory Calculator” available online that can help you do this, or you can make a calculated approximation using the information that follows. You will need to know your instrument’s installed memory size as determined in the previous section and then select your desired applications.

---

**NOTE**

If you have a PSA Series analyzer with Option 115, there is adequate memory to install all of the available optional personalities in your instrument.

To calculate the available memory on your PSA, see:  
[http://www.agilent.com/find/PSA\\_firmware](http://www.agilent.com/find/PSA_firmware)

Select the “Memory Calculator” link. You can try any combination of

available personalities to see if your desired configuration is compatible with your installed memory.



---

**NOTE** After loading all your optional measurement personalities, you should have a reserve of ~2 MBytes memory to facilitate mode switching. Less available memory will increase mode switching time. For example, if you employ excessive free memory by saving files of states and/or data, your mode switching time can increase to more than a minute.

---

You can manually estimate your total memory requirements by adding up the memory allocations described in the following steps. Compare the desired total with the available memory that you identified in the previous section.

1. Program memory - Select option requirements from the table “[Measurement Personality Options and Memory Required](#)” on [page 25](#).
2. Only: shared libraries require 7.72 MBytes.
3. Recommended mode swap space is 2 MBytes.
4. Screens - .gif files need 20-25 kBytes each.
5. State memory - State file sizes range from 21 kB for SA mode to 40 kB for W-CDMA. The state of every mode accessed since power-on will be saved in the state file. File sizes can exceed 150 kB each when several modes are accessed, for each state file saved.

---

**TIP** State memory retains settings for all states accessed before the **Save State** command. To reduce this usage to a minimum, reduce the modes accessed before the **Save State** is executed. You can set the PSA to boot into a selected mode by accessing the desired mode, then pressing the **System, Power On/Preset, Power On** keys and toggle the setting to **Last**.

---

### Measurement Personality Options and Memory Required

Personality Options for PSA Series Spectrum Analyzers <sup>a</sup>	Option	File Size (PSA Rev: A.10)
cdmaOne measurement personality	<b>BAC</b>	1.91 Mbytes
NADC and PDC measurement personalities (not available separately)	<b>BAE</b>	2.43 Mbytes
W-CDMA or W-CDMA, HSDPA, HSUPA measurement personality	<b>BAF, 210</b>	5.38 Mbytes <sup>b</sup>
cdma2000 or cdma2000 w/ 1xEV-DV measurement personality	<b>B78, 214</b>	4.00 Mbytes <sup>b</sup>
1xEV-DO measurement personality	<b>204</b>	5.61 Mbytes <sup>b</sup>
GSM (with EDGE) measurement personality	<b>202</b>	3.56 Mbytes <sup>b</sup>

Personality Options for PSA Series Spectrum Analyzers <sup>a</sup>	Option	File Size (PSA Rev: A.10)
Shared measurement library <sup>b</sup>	n/a	7.72 Mbytes
Phase Noise measurement personality	<b>226</b>	2.82 Mbytes <sup>c</sup>
Noise Figure measurement personality	<b>219</b>	4.68 Mbytes <sup>c</sup>
Basic measurement personality with digital demod hardware	<b>B7J</b>	Cannot be deleted (2.64 Mbytes)
Programming Code Compatibility Suite <sup>d</sup> (8560 Series, 8590 Series, and 8566/8568)	<b>266</b>	1.18 Mbytes <sup>c</sup>
TD-SCDMA Power measurement personality	<b>211</b>	5.47 Mbytes <sup>c</sup>
TD-SCDMA Modulation Analysis or TD-SCDMA Modulation Analysis w/ HSPA measurement personality	<b>212, 213</b>	1.82 Mbytes
Flexible Digital Modulation Analysis	<b>241</b>	2.11 Mbytes <sup>b</sup>
WLAN measurement personality	<b>217</b>	3.24 Mbytes <sup>b</sup>
External Source Control	<b>215</b>	0.72 Mbytes <sup>c</sup>
Measuring Receiver Personality (available with Option 23A - Trigger support for AM/FM/PM and Option 23B - CCITT filter)	<b>233</b>	2.91 Mbytes <sup>b</sup>
EMC Analyzer	<b>239</b>	4.06 Mbytes <sup>b</sup>

- a. Available as of the print date of this guide.
- b. Many PSA Series personality options use a 7.72 Mbyte shared measurement library. If you are loading multiple personalities that use this library, you only need to add this memory allocation once.
- c. Shared measurement library allocation not required.
- d. This is a no charge option that does not require a license key.

## Memory Upgrade Kits

The PSA 64 MByte Memory Upgrade kit part number is E4440AU-ANE. The PSA Compact Flash Upgrade kit part number is E4440AU-115.

For more information about memory upgrade kits contact your local sales office, service office, or see:

[http://www.agilent.com/find/sa\\_upgrades](http://www.agilent.com/find/sa_upgrades)

## Loading an Optional Measurement Personality

You must use a PC to load the desired personality option into the instrument memory. Loading can be done from a firmware CD-ROM or by downloading the update program from the internet. An automatic

loading program comes with the files and runs from your PC.

You can check the Agilent internet website for the latest PSA firmware versions available for downloading:

[http://www.agilent.com/find/psa\\_firmware](http://www.agilent.com/find/psa_firmware)

---

**NOTE**

When you add a new option, or update an existing option, you will get the updated versions of all your current options as they are all reloaded simultaneously. This process may also require you to update the instrument core firmware so that it is compatible with the new option.

Depending on your installed hardware memory, you may not be able to fit all of the available measurement personalities in instrument memory at the same time. You may need to delete an existing option file from memory and load the one you want. Use the automatic update program that is provided with the files. Refer to the table showing “[Measurement Personality Options and Memory Required](#)” on page 25. The approximate memory requirements for the options are listed in this table. These numbers are worst case examples. Some options share components and libraries, therefore the total memory usage of multiple options may not be exactly equal to the combined total.

## Obtaining and Installing a License Key

If you purchase an optional personality that requires installation, you will receive an “Entitlement Certificate” which may be redeemed for a license key specific to one instrument. Follow the instructions that accompany the certificate to obtain your license key.

To install a license key for the selected personality option, use the following procedure:

---

**NOTE**

You can also use this procedure to reinstall a license key that has been deleted during an uninstall process, or lost due to a memory failure.

1. Press **System, More, More, Licensing, Option** to access the alpha editor. Use this alpha editor to enter letters (upper-case), and the front-panel numeric keys to enter numbers for the option designation. You will validate your option entry in the active function area of the display. Then, press the **Enter** key.
2. Press **License Key** to enter the letters and digits of your license key. You will validate your license key entry in the active function area of the display. Then, press the **Enter** key.
3. Press the **Activate License** key.

## Viewing a License Key

Measurement personalities purchased with your instrument have been

installed and activated at the factory before shipment. The instrument requires a **License Key** unique to every measurement personality purchased. The license key is a hexadecimal number specific to your measurement personality, instrument serial number and host ID. It enables you to install, or reactivate that particular personality.

Use the following procedure to display the license key unique to your personality option that is already installed in your PSA:

Press **System, More, More, Licensing, Show License**. The **System, Personality** key displays the personalities loaded, version information, and whether the personality is licensed.

---

**NOTE** You will want to keep a copy of your license key in a secure location. Press **System, More**, then **Licensing, Show License Show System**, and print out a copy of the display that shows the license numbers. If you should lose your license key, call your nearest Agilent Technologies service or sales office for assistance.

---

### Using the Delete License Key on PSA

This key will make the option unavailable for use, but will not delete it from memory. Write down the 12-digit license key for the option before you delete it. If you want to use that measurement personality later, you will need the license key to reactivate the personality firmware.

---

**NOTE** Using the **Delete License** key does not remove the personality from the instrument memory, and does not free memory to be available to install another option. If you need to free memory to install another option, refer to the instructions for loading firmware updates located at the URL : <http://www.agilent.com/find/psa/>

---

1. Press **System, More, More, Licensing, Option**. Pressing the **Option** key will activate the alpha editor menu. Use the alpha editor to enter the letters (upper-case) and the front-panel numeric keyboard to enter the digits (if required) for the option, then press the **Enter** key. As you enter the option, you will see your entry in the active function area of the display.
2. Press **Delete License** to remove the license key from memory.

### Ordering Optional Measurement Personalities

When you order a personality option, you will receive an entitlement certificate. You will need to go to the Web site to redeem your entitlement certificate for a license key. You will need to provide your instrument serial number and host ID, and the entitlement certificate number.

Required Information:	Front Panel Key Path:
Model #: (Ex. E4440A)	
Host ID: _____	<b>System, Show System</b>

Introduction  
Installing Optional Measurement Personalities

<b>Required Information:</b>	<b>Front Panel Key Path:</b>
Instrument Serial Number: _____	<b>System, Show System</b>

---

---

## 2

# Making Measurements

This chapter describes procedures used for making Basic Mode measurements on cellular base stations or mobile stations. Instructions to help you set up and perform the measurements are provided, and examples of measurement results are shown.

## Basic Measurements

Basic measurements are useful for making measurements that are not specified in measurement standards, and will be useful if you need to troubleshoot a measurement operation. In addition, having spectrum and waveform measurements available independently of personality modes provides extra flexibility.

To access the Basic Mode press **MODE**, then **Basic**. The following measurements are then available by pressing **MEASURE**:

[“Spectrum \(Frequency Domain\) Measurements” on page 35](#)

[“Waveform \(Time Domain\) Measurements” on page 42](#)

[“Power Stat CCDF Measurements” on page 49](#)

When you press the key to select the measurement it will become the active measurement, using settings and a display unique to that measurement. Data acquisitions will automatically begin provided trigger requirements, if any, are met.

## PSA Options 122 and 140 Programming Control

This chapter includes information about how to set up and control the Option 122 or 140 wideband digitizer hardware. It shows how to use the SCPI programming commands to do some common measurement tasks. Additional Option 122 and 140 information is described in the Concepts chapter. See:

[“SCPI Control of the PSA Options 122 and 140 Wideband IF” on page 52](#)



---

## Setting up and Making a Measurement

### Making the Initial Signal Connection

---

**CAUTION**

Before connecting a signal to the instrument, make sure the instrument can safely accept the signal level provided. The signal level limits are marked next to the connectors on the front panel.

See “Input Key Menu” for details on selecting input ports and setting internal attenuation to prevent overloading the instrument.

The “Input Key Menu” also provides details of the internal preamplifier (**Int Preamp**) operation.

### Using Instrument Mode and Measurement Presets

If you want to set your current measurement personality to a known, factory default state, press **Preset**. This initializes the instrument by returning the mode setup and all of the measurement setups in the mode to the factory default parameters.

---

**NOTE**

Pressing the **Preset** key will switch instrument modes unless the type of preset is selected under **System, Power On/Preset** is set to **Mode** or **Save User Preset**.

To preset only the parameters that are specific to an active, selected measurement, press **Meas Setup**, then **Restore Meas Defaults**. **Restore Meas Defaults** will return all the measurement setup parameters to the factory defaults, but only for the currently selected measurement. The **Restore Meas Defaults** key may not appear on the first page of the **Meas Setup** menu. If not, press **More** until the key is available.

## The 3 Steps to Set Up and Make Measurements

All measurements need to be set up in 3 steps: first at the Mode level, second at the Measurement level, then finally the result display may be adjusted.

### 1. Select and Set Up the Mode

Press **MODE** - All licensed, installed Modes available are shown. Press or select **Basic** mode to make measurements of signals with non-standard formats.

Press **Mode Setup** - Make any required adjustments to the mode settings. These settings apply to all measurement in the mode.

### 2. Select and Set Up the Measurement

Press **MEASURE** - Select a specific measurement to be performed (for example, **Spectrum** or **Waveform**). The measurement begins as soon as any required trigger conditions are met. The resulting data is shown on the display or is available for export.

Press **Meas Setup** - Make any adjustments as required to the selected measurement settings. The settings only apply to this measurement.

### 3. Select and Set Up a View of the Results

Press **Trace/View** - Select a display format for the current measurement data. Depending on the mode and measurement selected, other graphical and tabular data presentations may be available. **X-Scale** and **Y-Scale** adjustments may also be made now.

---

**NOTE** A setting may be reset at any time, and will be in effect on the next measurement cycle or View.

---

Step	Primary Key	Setup Keys	Related Keys
1. Select & set up a Mode	<b>MODE</b>	<b>Mode Setup, Input/Output, FREQUENCY Channel</b>	<b>System</b>
2. Select & set up a Measurement	<b>MEASURE</b>	<b>Meas Setup</b>	<b>Meas Control, Restart</b>
3. Select & set up a View of the Results	<b>Trace/View</b>	<b>SPAN X Scale, AMPLITUDE Y Scale, Display, Next Window, Zoom</b>	<b>File, Save, Print, Print Setup, Marker, Peak Search</b>

## Spectrum (Frequency Domain) Measurements

This section explains how to make a frequency domain measurement on a cellular base station. An adjacent or an interfering signal can also be applied, if desired, during spectrum measurements.

If installed, you may use PSA Option 122, the 80 MHz Bandwidth Digitizer hardware, or PSA Option 140, the 40 MHz Bandwidth Digitizer hardware to perform Spectrum measurements of wideband signals using Basic Mode.

### Configuring the Measurement System

This example shows a base station (BTS) under test, set up to transmit RF power, and being controlled remotely by a system controller. The transmitting signal is connected to the analyzer RF input port. Connect the equipment as shown.

**Figure 2-1** Spectrum Measurement System

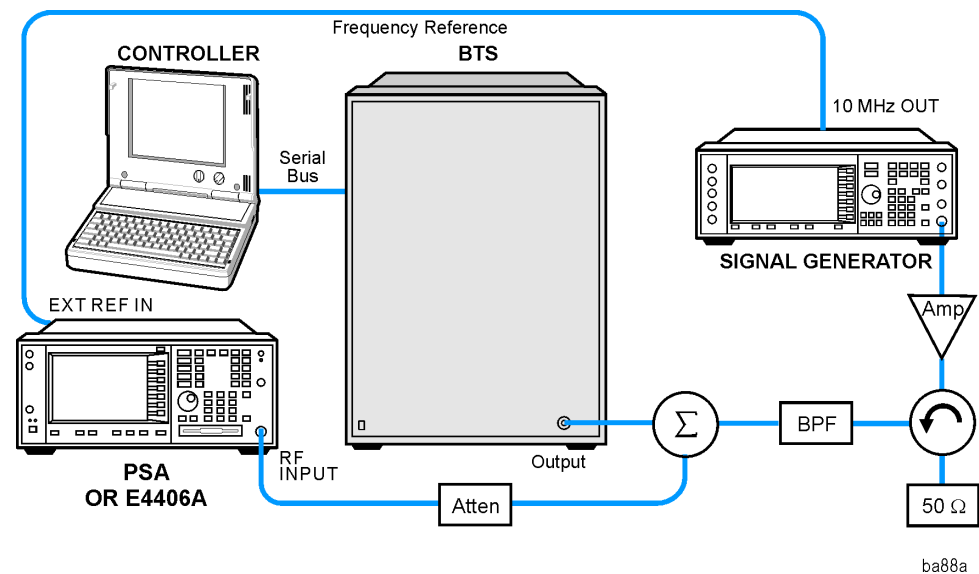

1. Using the appropriate cables, adapters, and circulator, connect the output signal of the BTS to the RF input of the instrument.
2. Connect the base transmission station simulator or signal generator to the BTS through a circulator to initiate a link constructed with sync and pilot channels, if required.
3. Connect a BNC cable between the 10 MHz OUT port of the signal generator and the EXT REF IN port of the instrument.
4. Connect the system controller to the BTS through the serial bus cable to control the BTS operation.

## Setting the BTS

From the base transmission station simulator and the system controller, set up a call using loopback mode to allow the BTS to transmit an RF signal.

## Measurement Procedure

- Step 1.** Press **Preset** to preset the instrument.
- Step 2.** Press **MODE, Basic** to enable the Basic Mode measurements.
- Step 3.** To set the measurement center frequency, press **FREQUENCY Channel** and enter a numerical frequency using the front-panel keypad. Complete the entry by selecting a units key, like **MHz**.
- Step 4.** Press **SPAN** and enter a numerical span using the front-panel keypad. Press **MHz** to set the measurement span in MHz.
- Step 5.** Press **MEASURE** to initiate the Spectrum measurement, which is the default measurement for the selected Mode.

---

**NOTE**

A display with both a Spectrum window and an I/Q Waveform window will appear when you activate a Spectrum measurement. The active window is outlined in green. Changes to **FREQUENCY**, **Span**, or **Amplitude** settings will affect only the active window. Use the **Next Window** key to select a different window, and the **Zoom** key to enlarge a window.

---

The default display shows both **Current** (yellow trace) and **Average** (blue trace) data. To make viewing the display easier, you can view either the **Current** trace or **Average** separately.

- Press **Trace/View, Trace Display**, and select the trace(s) desired for display.

**Figure 2-2**      **Spectrum Measurement - Spectrum and I/Q Waveform (Default**

**View)**

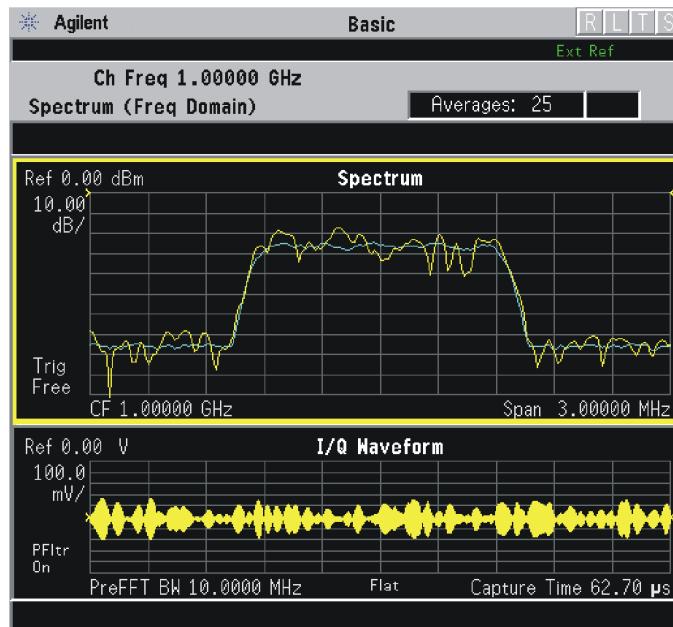

The spectrum measurement result should look like the above figure. The measurement result values are shown in the summary result window.

**Step 6.** Press **View/Trace** to display a menu allowing selection of another measurement result display, including the following:

- **Spectrum** - Provides a combination view of the Spectrum graph in parameters of power versus frequency with semi-log graticules, and the I/Q waveform graph in parameters of voltage and time. Changes to the frequency span or power will sometimes affect data acquisition. This is equivalent to changing the selected window with the **Next Window** key.

**Spectrum (Time Domain) I/Q Waveform** - This graph is shown below the Spectrum graph in the default dual-window display. I/Q Waveform provides a view of the I/Q waveform in parameters of voltage versus time in linear scale. Changes to sweep time or resolution bandwidth can affect data acquisition.

Figure 2-3 Spectrum (Time Domain) Measurement - I/Q Waveform Result

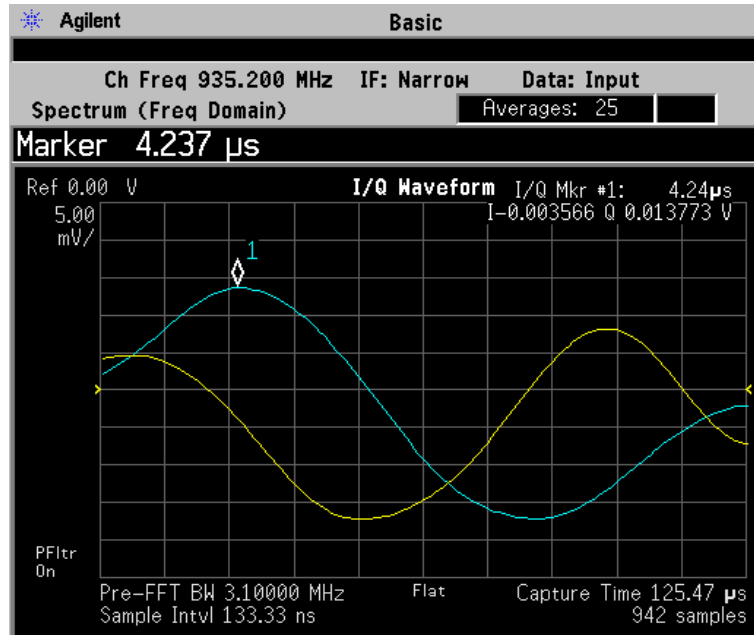

**Step 7.** To make a measurement repeatedly, press **Meas Control**, **Measure** to toggle the setting from **Single** to **Cont**.

**Step 8.** If Option 122 or 140 is installed, you may use the wideband IF hardware to view a wide bandwidth signal in the Spectrum view. The I/Q Waveform view will be correctly demodulated to the I and Q components over the entire display bandwidth.

- Press **MODE**, and select **Basic** to be able to use the Wideband IF path.
- Press **MEASURE**, and select the **Spectrum** measurement.
- Press **MEAS SETUP** and toggle the **IF Path** key to select **Wide**. Adjust the span to view up to 80 MHz for Option 122, or up to 40 MHz for Option 140 around your selected center frequency.

Figure 2-4 is an example of a 54 carrier OFDM signal which has a – 10 dB bandwidth greater than 16 MHz, with skirts to over twice that bandwidth. Delta markers are shown measuring the peak bandwidth.

**Figure 2-4** Spectrum Measurement - Spectrum Zoom View with Opt. 122–80 MHz Bandwidth Digitizer Hardware

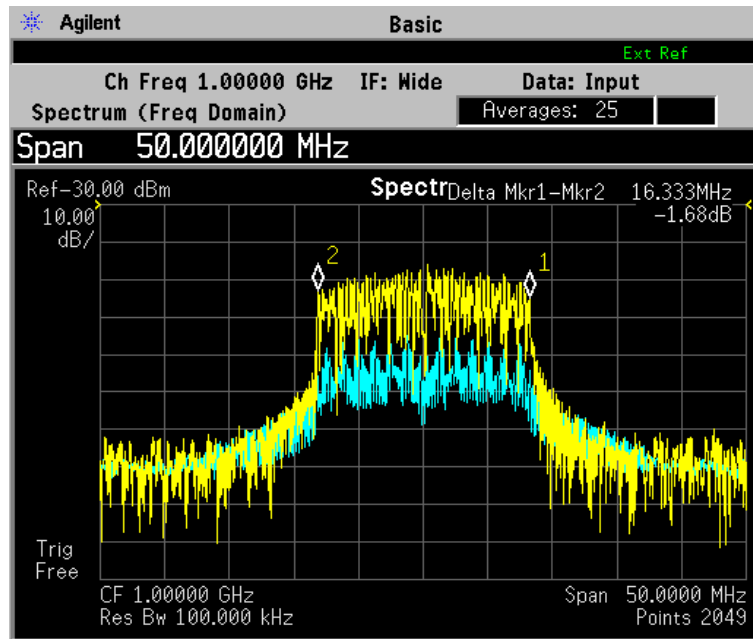

Figure 2-5 is an example of a 802.11 WLAN signal which has an instantaneous bandwidth of over 36 MHz. Only the Average trace is displayed.

When using the widest spans, the Resolution Bandwidth may be limited by the maximum number of points available for a Spectrum measurement. If your desired setting exceeds the available number of points, the maximum number available will be used, and an error message will be displayed.

**Figure 2-5** Spectrum Measurement - Spectrum Zoom View with Opt. 122–80 MHz Bandwidth Digitizer Hardware

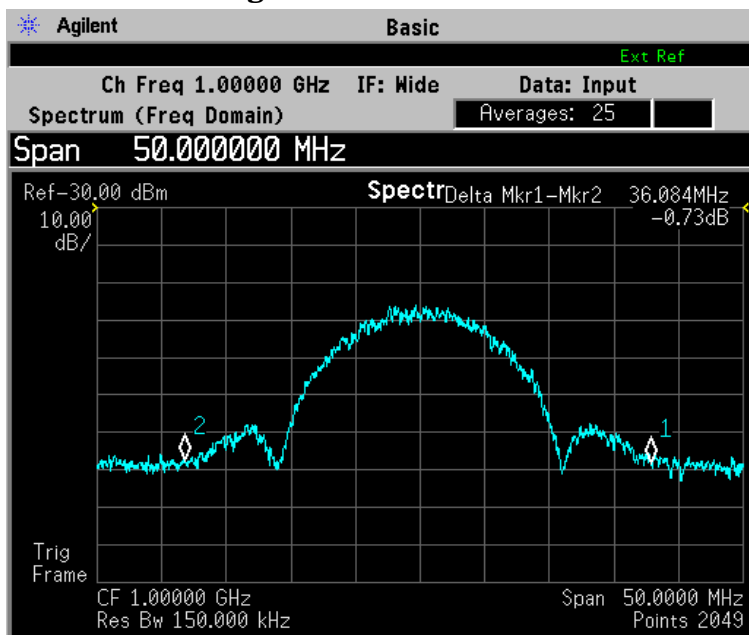
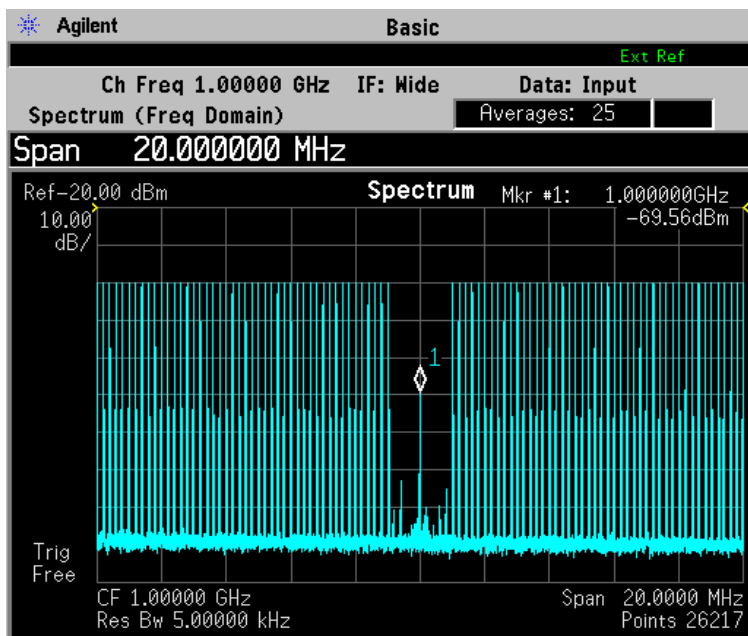

Figure 2-6 is an example of a Spectrum View of the center 20 MHz of a Noise Power Ratio measurement. If you extend the Span to the full 80 MHz bandwidth, individual carriers displayed may merge, as they can be limited by screen resolution and resolution bandwidth. Only the Average data trace is displayed in the example below.

**Figure 2-6** Spectrum Measurement - Spectrum View with Opt. 122–80 MHz Bandwidth Digitizer Hardware





The wideband signal example shown below is 16 W-CDMA carriers, each occupying 5 MHz of bandwidth. The full 80 MHz of available demodulation bandwidth for the Spectrum measurement is used. Only the Average trace is displayed. Note the demodulated composite I/Q waveform for the entire 80 MHz BW signal in the **I/Q Waveform** window below. A peak search marker has been applied to the composite waveform.

**Figure 2-7** Spectrum Measurement - Spectrum Zoom View with Opt. 122–80 MHz Bandwidth Digitizer Hardware

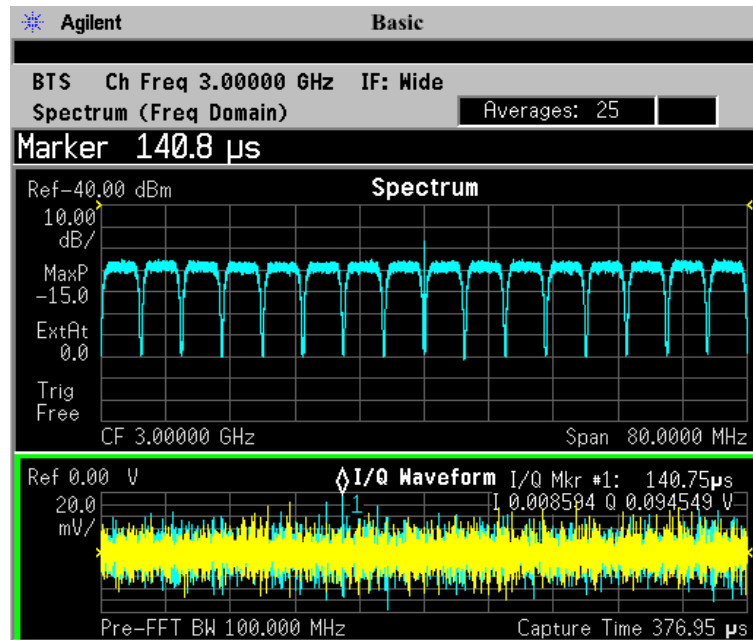

**Step 9.** Press **Meas Setup, More** to check the keys available to change the measurement parameters from the default condition.

## Waveform (Time Domain) Measurements

This section explains how to make Waveform (Time Domain) measurements on a cellular base station. Measurement of I and Q modulated waveforms in the time domain disclose the voltages which comprise the complex modulated waveform of a digital signal.

If installed, you may use PSA Option 122, the 80 MHz Bandwidth Digitizer hardware, or PSA Option 140, the 40 MHz Bandwidth Digitizer hardware to perform Waveform measurements of wideband signals using Basic Mode.

### Configuring the Measurement System

The base station (BTS) under test has to be set to transmit the RF power remotely through the system controller. This transmitting signal is connected to the instruments RF input port. Connect the equipment as shown. An interfering or adjacent signal may be supplied as shown.

**Setting the MS** From the base transmission station simulator (signal generator) and the system controller, set up a call using loopback mode for the MS to transmit the RF signal.

**Figure 2-8** Waveform Measurement System

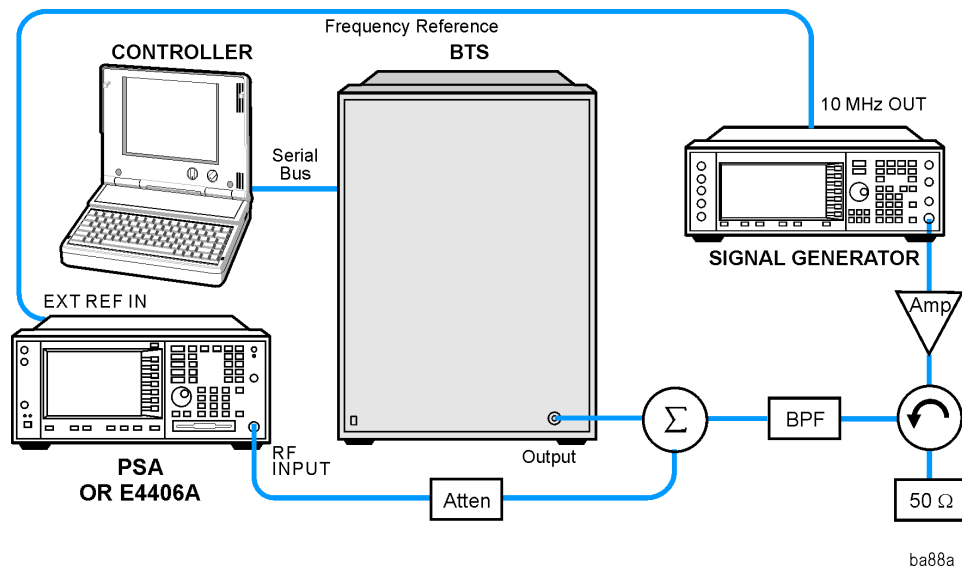

1. Using the appropriate cables, adapters, and circulator, connect the output signal of the BTS to the RF input of the instrument.
2. Connect the base transmission station simulator or signal generator to the BTS through a circulator to initiate a link constructed with sync and pilot channels, if required.

3. Connect a BNC cable between the 10 MHz OUT port of the signal generator and the EXT REF IN port of the instrument.
4. Connect the system controller to the BTS through the serial bus cable to control the BTS operation.
5. Connect an external trigger, if needed. Press Mode Setup, Trigger to access a menu to set up inputs and levels for all triggers. You must then select the appropriate trigger under the Meas Setup, Trigger menu to direct the measurement to use your trigger settings.

**Setting the BTS** From the mobile simulator (signal generator) and the system controller, set up a call using loopback mode for the BTS to transmit the RF signal.

## Measurement Procedure

- Step 1.** Press **Preset** to preset the instrument.
- Step 2.** Press **MODE, Basic** to enable the Basic Mode measurements.
- Step 3.** To set the measurement center frequency, press **FREQUENCY Channel** and enter a numerical frequency using the front-panel keypad. Complete the entry by selecting a units key, like **MHz**.
- Step 4.** Press **SPAN** and enter a numerical span using the front-panel keypad. Press **MHz** to set the measurement span in MHz.
- Step 5.** Press **MEASURE** to initiate the Waveform measurement.

The default display shows both **Current** (yellow trace) and **Average** (blue trace) data. To make viewing the display easier, you can view either the **Current** or **Average** trace separately.

- Press **Trace/View, Trace Display**, and select the trace(s) desired for display.

- Step 6.** Press **SPAN X Scale**, and the up or down arrow key until the waveform is shown at a convenient time scale for viewing.

If installed, you may use the 80 MHz Bandwidth hardware to view a wideband signal in the RF Envelope view.

Press **SPAN** and select the **Wideband** RF Path. Adjust the span to view up to 80 MHz around your selected center frequency.

**Figure 2-9** shows an example of an RF Envelope result for a Waveform (Time Domain) measurement. The measured values for the mean power and peak-to-mean power are shown in the text window.

**Figure 2-9** Waveform Measurement - RF Envelope (Default View)

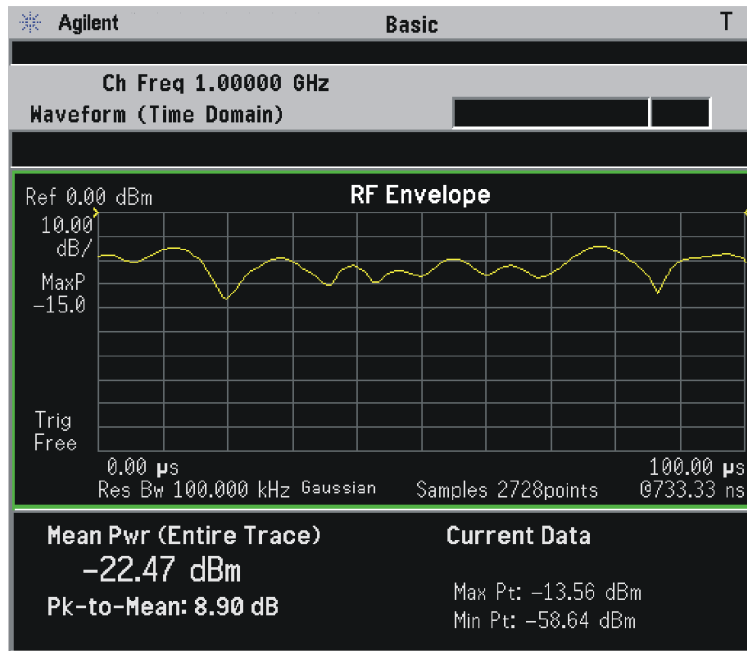

\*Meas Setup: Trace/View = RF Envelope,  
Others = Factory default settings

\*Input signal: cdma2000 Rev 8, SR1, 9 Channel

**Step 7.** Press **Trace/View** to display the menu allowing selection of the other Waveform views, including the following:

- **I/Q Waveform** - Provides a view of the I and Q waveforms together on the same graph in parameters of voltage versus time in linear scale. Changes to the sweep time or resolution bandwidth can affect data acquisition.

**Figure 2-10** Waveform Measurement - I/Q Waveform View

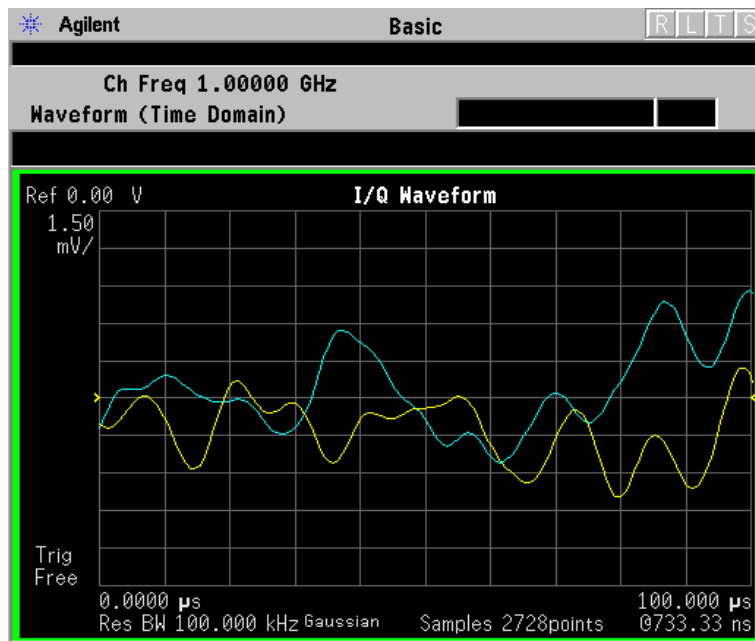

**NOTE**

For the widest spans, the I/Q Waveform window becomes just “ADC time domain samples”, because the I/Q down-conversion is no longer in effect.

- Step 8.** If PSA Option 140 or 122 is installed, you may use the 40 or 80 MHz Bandwidth hardware to view a wideband signal in the Waveform view. Even if you are not interested in a wideband signal, using the Wideband IF path provides powerful measurement flexibility, including to the ability to accurately set practically any sample rate and thereby resample waveforms. Resampling, or oversampling, at the correct rate allows you to effectively obtain an integer number of samples per symbol. Make sure that the sample time is aligned with the decision points of the symbols to make analysis of measurement data much easier.

The following example of performing a Wideband IF Waveform measurement of a GSM burst will show the technique to accurately align and resample a signal:

- Press **Mode**, and select **Basic** to be able to use the 80 MHz IF path.
- Press **MEASURE**, and select the **Waveform** measurement.
- Press **Trace/View** and select the **RF Envelope** view.
- Press **SPAN** and toggle the **IF Path** key to select **Wide**. Adjust the span to view up to 80 MHz around your selected center frequency. Note the example below has 1 million data points.

**Figure 2-11** Waveform Measurement - RF Envelope View with Opt. 122– 80 MHz Bandwidth Digitizer Hardware

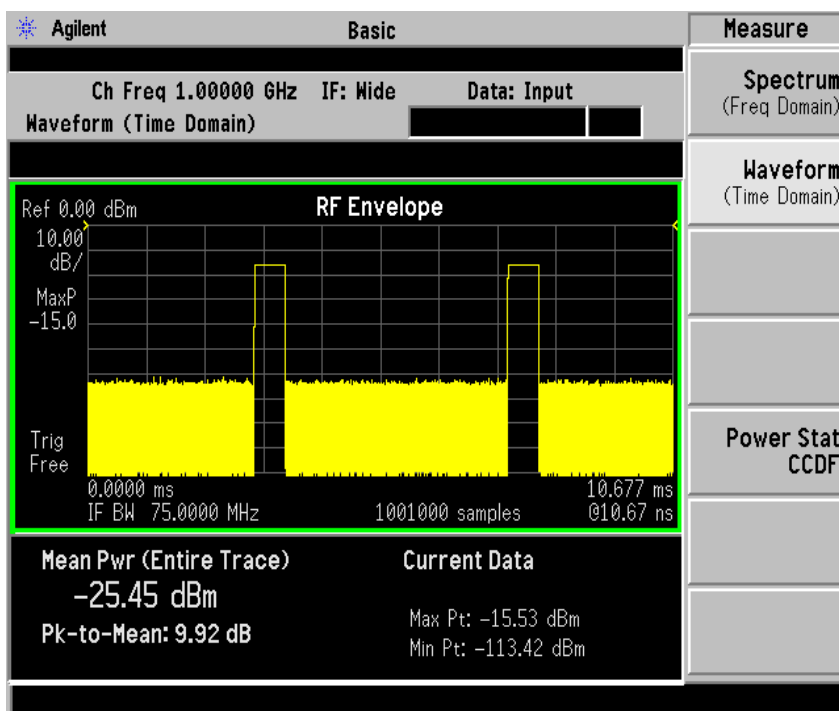

- Make sure that your samples are synchronized to the decision points of the signal of interest. In this case we will use the internal Frame Timer to trigger our measurement. A GSM frame is 4.615383 ms long.

Press **Mode Setup**, **Trigger**, select **Frame Timer**, then select **Period**. Enter 4.615383 ms. This only sets the frame timer period. You must direct the measurement to use the Frame Timer in the next step:

Press **Meas Setup**, **Trigger Source** and select **Frame**.

For other measurements, an external trigger may be applied to an External Trigger Input, on either the front or the rear panel. You must specify that trigger selection in this menu.

- In this example, we want to capture an entire GSM burst of 144 symbols (plus guard). A GSM burst is approximately 4.6 ms, so we will set our **Meas Time** to 5 ms:

Press **Meas Setup**, **Meas Time** and enter 5 ms.

- In this resampling example, we want to take exactly 10 samples per GSM symbol. The GSM symbol rate is 270.833 kHz, so we want a sample rate of 2.70833 MHz. Option 122 Wideband IF hardware lets

us set the desired sample rate, as follows: sample rate = 5/4 IF Bandwidth. That means we need set an IF BW of 2.16667 MHz. Press **Meas Setup, IF BW** and enter 2.16667 MHz.

You can also access the sample rate key directly:

Press **Meas Setup, Wideband Setup, Sample Rate**. Enter the **Sample Rate** frequency. The **Sample Rate** and **IF BW** settings are coupled. The 5/4 ratio will be preserved regardless of which setting is used.

- Your measurement result should look like [Figure 2-12](#)

**Figure 2-12** Waveform Measurement - RF Envelope View with Opt. 122–80 MHz Bandwidth Digitizer Hardware

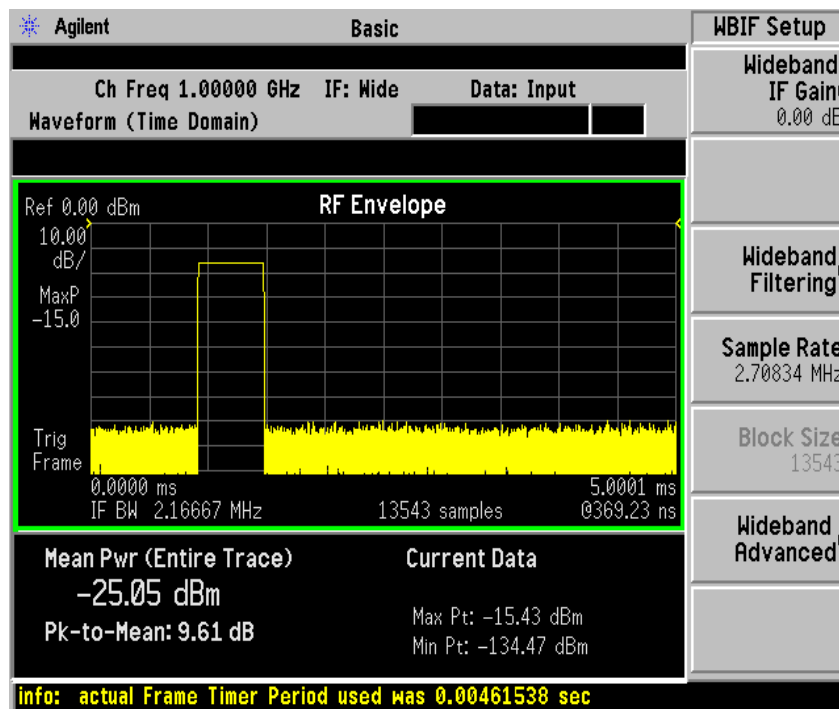

- Step 9.** Press **AMPLITUDE Y Scale** and the up arrow or down arrow key until the waveforms are shown at a convenient voltage scale for viewing.
- Step 10.** Press **SPAN X Scale** and the up arrow or down arrow key until the waveforms are shown at a convenient time scale for viewing.
- Step 11.** Press **Marker, Trace, I/Q Waveform** to activate a marker. Rotate the **RPG** knob until the marker is shown at a desired time in the waveform for viewing the trace values at the time position of the marker.
- Step 12.** To make a measurement repeatedly, press **Meas Control, Measure** and toggle to **Cont**.
- Step 13.** Press **Meas Setup, More** to check the keys available to change the

measurement parameters from the default condition.

## Using the Waveform Measurement to Set Up Triggering (for burst signals)

You can use the Waveform measurement to view your signal in the time domain and to help select the appropriate trigger to acquire your signal.

- Step 1.** Press **MEASURE, Waveform (Time Domain)** to activate the Waveform measurement view.
- Step 2.** Press **SPAN X Scale, Scale/Div** to adjust the scale of the x-axis to view the complete signal waveform. Use the front-panel keypad to input the **scale/div**, then press a units key, like  $\mu\text{s}$ , to complete the entry.
- Step 3.** Press **Meas Setup, Trig Source**, then select one of the available trigger sources (free run is the default setting).
- Step 4.** Press **Trig**, then choose a trigger mode to set up the trigger conditions.

In the trigger mode, set the delay, peak level, and positive or negative edge slope trigger. You can also set up trigger holdoff, auto trigger timing, and frame timer settings.



---

## Power Stat CCDF Measurements

This section explains how to make a power statistics CCDF measurement in Basic Mode.

---

### NOTE

The PSA Series analyzer **MUST** have the wideband digital IF option (Option 122 or 140) to make power stat CCDF measurements in Basic Mode. If Option 122 or 140 is not installed in your analyzer, the **Power Stat CCDF** key will not appear in the Basic Mode Measure menu. Only the **Spectrum** and **Waveform** keys will be shown.

Power Complementary Cumulative Distribution Function (CCDF) curves characterize the higher level power statistics of a digitally modulated signal.

The results are displayed graphically as well as in a Metrics window.

---

### NOTE

The CCDF measurement does not have Pass/Fail indicators.

## Measurement Procedure

- Step 1.** Press **Preset** to preset the instrument
- Step 2.** Press **MODE**, then **Basic** to enable the Basic Mode measurements.
- Step 3.** Press **MEASURE**, **Power Stat CCDF** to initiate the power statistics CCDF measurement.

The CCDF measurement result should look like [Figure 2-13 on page 50](#). The measurement results for Average Power and the power statistic data are shown in the Metrics window on the left-hand side of the screen. The tested CCDF curve is indicated by the yellow line.

Figure 2-13 Power Statistics CCDF Result - Basic Mode

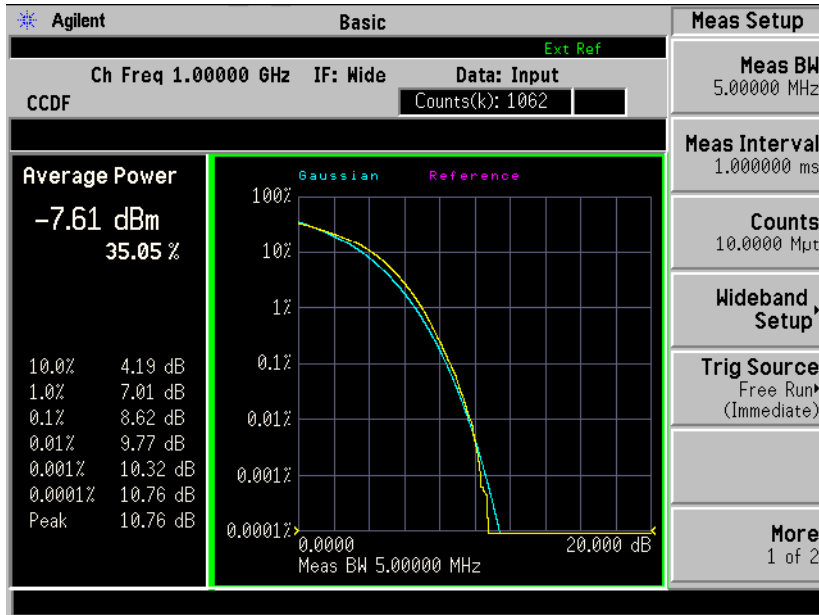

**Step 4.** Press the **Meas Setup** to change the measurement parameters from their default conditions.

In an OFDM signal, the burst includes training symbols, the signal field and the data field. To accurately perform a useful CCDF measurement of a device such as a power amplifier (PA), only the signal and data portions of the burst should be included and the measurement must be made on the data portion. This can be done by adjusting the trigger parameters within the CCDF measurement:

First, identify the total length of the burst. This can be done using the **Waveform Measurement**. You can use **Waveform (Time Domain)** measurement to show the whole burst, place a marker on the left edge of the burst, then use the knob to place a delta marker at the falling edge of the same burst. The length of the burst will be displayed at the top left of the Waveform window. You need to select the correct trigger source to get a stable signal display and then use the marker to determine the burst length. For example, you read the burst length.

Second, select the **Power Stat CCDF** measurement and set the correct **Trig Source** in the **Meas Setup** menu, like **Ext Front**.

Third, select the appropriate **Meas Interval** in the **Meas Setup** menu. Then set trigger offset for CCDF measurement by pressing **Trig** and **Ext Front**.

The training portion of the OFDM burst occupies the first trigger offset, so the CCDF measurement should only analyze the portion of the burst from the offset to the burst length.

Now you should get the CCDF result. If not, press **Restart**.

For more details about changing measurement parameters, see Power Stat CCDF “[Meas Setup](#)” on page 208.

**Step 5.** To change the display scale, press the **SPAN/X Scale** key, enter a value for **Scale/Div** key, then press the **dB** key.

**Step 6.** To change the display parameters, press the **Display** key:

Press **Store Ref Trace** to define user’s reference trace.

The reference trace can be toggled **On** or **Off** by pressing the **Ref Trace** key.

The gaussian line can also be toggled **On** or **Off** by pressing the **Gaussian Line** key.

To change a display parameter like AMPLITUDE/Y Scale, **Scale/Div** the window must be made “active”, which is shown on the display as the window with a green outline. Press Next Window to activate the other window, and Zoom to display only a single window.

If you have a problem, and get an error message, see the “Instrument Messages and Functional Tests” manual.

---

## SCPI Control of the PSA Options 122 and 140 Wideband IF

This section summarizes some recommended programming control sequences for making measurements and retrieving data using a PSA that has Option 122 or 140, wideband IF bandwidth digitizer.

### What does Option 122 or 140 Do?

PSA Options 122 and 140 offer 80 MHz or 40 MHz real time data capture, respectively. The acquisition system captures  $200 \times 10^6$  samples/sec. That data is then passed through a digital IQ converter that also applies flatness correction. At the output of the IQ converter, the data rate is  $100 \times 10^6$  complex samples per second. Following the IQ converter is an arbitrary resampler, so the system is able to provide any sample rate from 12.5 kHz to 100 MHz. If, for example, you were planning on demodulating a signal, you can have the PSA acquire the data with an integer number of samples per symbol.

When resampling the data, the instrument first applies a digital filter to remove signals and noise above the resampled Nyquist rate. This has the significant benefit of reducing the total noise per sample linearly with the sample rate reduction. Note, however, that the noise density remains the same.

After the data is acquired, it flows into a memory configured as a circular buffer. This allows the instrument to wait a long time for a trigger, with data continuously flowing. Once the trigger is received, the instrument can then provide up to 100 ms of pre-trigger data or 500 ms of post-trigger delay.

### Acquiring Time Data

When using the PSA with Option 122 or 140 to acquire time data to be transferred, we recommend that you use the Waveform measurement in Basic mode. It is the most efficient, and allows you to capture up to 1 million samples in a single record. If you need more than 1 million samples, the instrument offers a deep capture mode that will acquire 128 million samples at sample rates  $\geq 25$  MHz, and 64 million samples  $< 25$  MHz. Below 25 MHz, the DSP hardware carries more resolution, and therefore stores fewer bandwidth samples. Each sample is a complex pair.

The [Table on page 53](#) describes a typical measurement set up and acquisition, listing the SCPI commands and how to use them.

**Table 2-1 Waveform Measurement Sequence**

Action	SCPI	Comments
Abort the current activity.	[Selected Device Clear] *CLS	How to send selected device clear varies by interface, but all interfaces can send one. Many users send *IDN? to get the instrument model and serial number at this point.
Set the instrument mode to BASIC.	:INST:SEL BASIC	
Preset BASIC	*RST	Assuming Preset Type is Mode (the factory default)
Set the measurement to Waveform.	:INIT:WAV	
Put instrument in single sweep mode.	:INIT:CONT OFF	
To make the instrument run faster, optionally turn off the display and turn off trace conversion.	:DISP:ENAB 0 :WAV:NCPT 1	This step and the previous ones are initial activities that don't need to be repeated for measurements after the first one. Note that turning dB computation off, turns off all results in dB or dBm on the display or from a SCPI query.
Set the IF Path to Wide, turning on the 80 MHz or 40 MHz BW path.	:WAV:IFP WIDE	
Set the center frequency.	:FREQ:CENT 1.25e9	Use whatever frequency you need. (The default unit is Hz.)
Set the acquisition time.	:WAV:SWE:TIME 150e-6	The number of samples will be acquisition_time * sample_rate + 1. (Default unit is seconds.)
Set the sample rate.	:WAV:SRAT 50e6	The IF BW will be 0.80 * sample_rate (40 MHz in this case.)

**Table 2-1 Waveform Measurement Sequence**

Action	SCPI	Comments
Optionally select the trigger source.	:WAV:TRIG:SOUR <choice> where choice is one of: IMM, FRAME, EXT1 (front), EXT2 (back), IF (video)	IMM (Free run) is the default.
Configure the trigger source if using Video, External or Frame triggers.	(See commands for individual trigger types in TRIGger subsystem.)	
Take a Sweep.	INIT;*OPC?	The operation complete query is included for proper synchronization.
Wait for sweep to finish.	(Enter OPC response, or poll MAV bit with Serial Poll.)	Make sure your SCPI timeout is long enough to wait for the trigger and the acquisition. If you need to abort a measurement, send selected Device Clear.
Read Trace Back	:FORM:BORD NORM; :FORM REAL,32; :CALC:DATA0?  Then use the Agilent VISA COM library to read back the formatted data. See the VISA COM help under FormattedIO 488 for details on using the read IEEEBlock method.	Set byte order for PC. Read back 32 bit integers. Request IQ time data.
If using external or line trigger, read back trigger error offset.	:WAV:TRIG:EOF?	If the trigger occurred between samples, and the instrument wasn't able to interpolate the data to remove the error, then the error is returned in seconds.

## Making Deep Data Captures

The PSA Waveform measurement trace length is limited to 1 million points. To capture and read back more data, the PSA Option 122 and 140 offers a deep capture function, where multiple records are captured in memory for a total of up to 128 million samples. Each record is then read back as a trace.

The intended use of deep capture is to first get the conditions set up using the normal measurement. Once you are ready to commit to a very large capture, use the **Fill Capture** function. Option 122 can capture 128 million samples for sample rates  $\geq 25$  MHz. Below 25 MHz, the DSP carries more resolution and can only store 64 million samples.

The sequence below shows the SCPI commands to capture data using conditions that have already been configured. And then read the data back into the computer.

**Table 2-2 Waveform Measurement, Deep Capture Sequence**

Action	SCPI	Comments
Follow the sequence described in <a href="#">Table 2-1 on page 53</a> . Stop before doing the “Take A Sweep” step.		
Set Capture Time	:TCAP:TIME 0.0025	2.5 ms in this case
Trigger the Capture	:INIT:TCAP;*OPC?	The operation complete query is included for proper synchronization.
Wait for the capture to complete.	Either read back the OPC response, or serial poll the MAV bit.	
Set record number to 1.	:TCAP:NREC 1	The initial trigger caused the instrument to read the first record. If we then send a READ? command, we will get the second record, so we must tell it to go back to the first record.
Read the number of records.	:TCAP:LREC?	The instrument does not process partial records, so it is best to read back the exact number of records available. The LREC (last record) value is reset to the number of records after each deep capture. (It can be changed later from the front panel.)

**Table 2-2**      **Waveform Measurement, Deep Capture Sequence**

Action	SCPI	Comments
Prepare for transfer.	:FORM:BORD NORM; :FORM REAL,32;	Set byte order for PC Read back 32 bit integers
For each record, read the trace and store it locally.	:READ:WAV0?  Then use the Agilent VISA COM library to read back the formatted data. See the VISA COM help under FormattedIO 488 for details on using the read IEEEBlock method.	Do each trace transfer is as shown in <a href="#">Table 2-1</a> . Depending on how much storage you have, you can then either append each trace to a data file, or concatenate the arrays in memory.
If using external or line trigger, read back the trigger error offset.	:WAV:TRIG:EOF?	A deep capture involves so much data that the instrument will not attempt to interpolate the data to the trigger point. So there will always be a nonzero error for external triggers of a deep capture.

### Reducing Noise with Hardware Time Averaging

For PSA Options 122 and 140, the Frame trigger allows picosecond synchronization between data acquisition and signal repetition. This capability can be used to do hardware time averaging in the DSP hardware to reduce noise.

There is a class of signals that are inherently periodic. For example, any signal generated with an arbitrary waveform generator (arb) will be periodic. The arb has a finite amount of sample memory and a known sample rate. The PSA Option 122 or 140 can take advantage of these signals by synchronizing the data acquisition with the repetition of the input signal. To achieve the greatest precision, the PSA and the test signal have to be configured so that the test signal repetition is an integer number of PSA samples. This avoids having a trigger signal that crosses clock domains. It allows the PSA Option 122 or 140 to use its internal sample clock to generate a frame trigger with picosecond accuracy. To use this functionality, you only need a common 10 MHz reference. You don't have to provide an explicit trigger line.

You can make the signal period be an integer number of PSA samples either by adjusting the signal itself or by adjusting the PSA wideband IF option sample rate. Remember that the PSA wideband IF option has



an arbitrary resampler, so you can control the output sample rate very precisely. You might have a signal repetition rate that is a non-repeating fraction (such as 22 1/3 ms). You can make this work if an integer number of signal periods is an integer number of clock samples. In the example just given, we would tell the PSA that the signal period is three times 22 1/3, or 67 ms.

If you are using an Agilent PSG or ESG to generate the signal, you can find the signal period for signals generated using the Dual Arb by selecting **Mode, Arbitrary Waveform Generator, Dual Arb**. That tells you the sample clock rate, and selecting **Waveform Segments** will tell you the number of samples. If you used one of the standard source signal formats, it will be loaded as the “AUTOGEN\_WAVEFORM.”

Once the data acquisition is synchronized with the signal period, you will notice that the time trace freezes. The waveform repeats for each acquisition (except for the noise). In the PSA this type of trigger is called **Frame** trigger and it is controlled by the **Frame Timer**.

The **Frame Timer** has an offset function that allows you to scan through the signal. In addition, the frame timer has a sync function. If you have a trigger line from the signal source that is synchronous with the signal period, then it can be used to sync the frame timer. The frame timer will wait for the sync signal before it starts up, and it will start synchronously with the sync signal.

Once it has started, the frame timer uses its internal clocking and ignores the sync signal. To resync, you must set the trigger back to **Free Run**, then back to **Frame**. The sync signal must be connected to either the front or back external trigger input. You can use the external trigger settings to adjust the level and delay.

Once you have set up the frame trigger you might want to do time averaging. Since the time waveform repeats, while any noise that is present does not repeat, you can reduce the noise by averaging a few traces together. The PSA Options 122 and 140 have hardware time averaging, so an increased frame timer period is the only cost for doing averaging. For example, if the frame timer period is 100 microseconds, then 1000 averages will only take 100 ms.

Hardware time averaging is only available when the frame trigger is active and time averaging is turned on by specifying a **Time Avg Num** that is greater than one.

In order for hardware time averaging to work, all the clocks and oscillators in the system have to be tied to a common 10 MHz reference. This includes the Arb clock and the RF synthesizer used to upconvert the signal. If there is any downconversion done before the signal is passed to the PSA, then that local oscillator must also be tied to the 10 MHz reference.

It is best to experiment from the front panel before creating your remote program. Make sure that the signal freezes in time, when the

frame trigger is turned on. Also check that its amplitude does not drop when hardware time averaging is turned on. If the amplitude drops, then the system is not properly synchronized. Check that the frame timer period is correct. Check that the frame timer period requested is an integer number of samples. Also check that everything is locked to the common 10 MHz reference.

**Table 2-3**      **Frame Trigger and Hardware Averaging Example**

Action	SCPI	Comments
Follow sequence from <a href="#">Table 2-1 on page 53</a> to set up the basic measurement. This table discusses how to set up the triggering and averaging.		
Enter the <b>Frame Timer</b> period.	:TRIG:FRAM:PER 10e-3	10 ms period, such as in a WCDMA signal.
If necessary, set the sample rate.	:WAV:SRAT 50e6	This is a 20 ns sample period, so there is an integer number of samples in 10 ms.
Optionally set up an external sync signal.	:TRIG:FRAM:SYNC EXTF  :TRIG:EXT:LEV 1.3 :TRIG:EXT:DEL 1.4e-	Other options are NONE for no sync, EXTR for external rear.  Set the level in volts and delay in seconds. (Delay must be positive.) Use EXT2 to set rear panel input values.
Set the number of hardware time averages.	:WAV:AVER:TAC 20	
Turn on the frame trigger.	:WAV:TRIG:SOUR FRAM	
At this point, initiate the measurement and transfer the data using the process described in <a href="#">Table 2-1 on page 53</a> . The data transferred has already been time averaged, but it looks like a normal trace.		

## Turning Alignments Off

The internal self-alignment process occurs automatically. You cannot predict when the alignments will happen and they can interrupt your program flow in unexpected ways. So, you should turn alignments off while you are actively controlling the instrument:

```
:CAL:AUTO OFF
```

However, if you have turned alignments off, you will then need to check periodically to see if the instrument needs alignment. This can be done

by querying the alignment needed bit. That is bit 14 in the questionable calibration status register. For information covering how to do a device clear over the LAN socket port 5025, see the “Socket LAN Clear Device Example for PSA” section in the *PSA User’s and Programmer’s Reference Volume 1*.

STAT:QUES:CAL?

Alternatively, you can briefly turn alignments back on. The instrument will do any required alignments at that point.

## Using LAN Ports with Visual Basic 6.0

The LAN socket port 5025 is the fastest port available. So it is a good port for large data transfers. Note that it does not have EOI indicators.

---

**NOTE**

An additional programming example to demonstrate performing a device clear using sockets is available in the *User's and Programmer's Reference Volume 1*.

---

### Example using Visual Basic 6.0

This programming example can be found in a file on your PSA Documentation CD and is also on the Agilent PSA website.

**Step 1.** Make sure a current version of Agilent IO libraries is installed on your PC.

**Step 2.** Open Visual Basic 6.0 and start a New Project.

Select "Standard EXE" as the project type.

Save the project with the form name "VisaExample".

**Step 3.** Bring in the Visa COM objects by clicking Project, then References. You need two references:

- Agilent VISA COM Resource Manager 1.0
- VISA COM 1.0 Type Library

Find them and check their boxes. Then select OK. If they are not in the reference list, you need to reinstall the Agilent IO libraries.

**Step 4.** Now go to the form1 window and right click on it.

Then select "View Code".

Paste the following code into that window:

In order to run this example, you will need to:

- a. Run the Agilent VISA Assistant.  
Right click on the IO icon on the bottom right of your pc screen. Select "Run VISA Assistant". It will locate your instrument. Click on it. Then you can copy the Visa Resource string into the OpenPSA call in Form\_Load.
- b. If you want to send commands to your instrument using the LAN, run "IO Config" by right clicking on the IO icon. Then select the TCPIP interface type and click configure. Accept the defaults and click ok. Now locate the TCPIP driver on the configured interfaces list. Click Edit, then click Edit VISA Config. Type in the network name for you PSA and leave the device name blank.

- Now exit.  
 c. Re-run the Visa Assistant, and it will find your PSA.

```
Dim psa As VisaComLib.FormattedIO488

Private Function OpenPSA(visaString As String) As VisaComLib.IMessage
On Error GoTo errorHandler
  Dim rm As AgilentRMLib.SRMCLs
  Dim session As VisaComLib.IMessage
  Dim status As Long
  Dim idn As String
  ' Create the Agilent-Specific VISA Resource Manager
  Set rm = New AgilentRMLib.SRMCLs
  ' Open the session with the default values for the Lock (None), Timeout(N/A),
  ' and Option String (""). The return value is an IVisaSession, but the
  ' session variable is an IMessage interface reference, causing an implicit
  ' IUnknown::QueryInterface() to occur. VB handles the details.
  Set session = rm.Open(visaString)

  ' Send Selected Device Clear to abort current activity
  session.Clear
  ' Clear out the status reporting mechanism
  session.WriteString "*rst" & Chr(10)
  session.WriteString "*CLS" & Chr(10)
  ' Read the identity string
  session.WriteString "*IDN?" & Chr(10)
  idn = session.ReadString(100)
  MsgBox "The IDN String is: " & idn, vbOKOnly, "IDN? Result"

  Set OpenPSA = session
Exit Function
errorHandler:
```

```
MsgBox Err.Description, vbExclamation, "Error Occurred", Err.HelpFile, Err.HelpContext  
End Function
```

```
Private Sub Form_Load()  
    Dim session As VisaComLib.IMessage  
  
    ' Open session with the PSA. Be sure to replace PSA_NETWORK_NAME  
    ' with the name or IP address of your PSA.  
    Set session = OpenPSA("TCPIP0::PSA_NETWORK_NAME")  
    Set psa = New VisaComLib.FormattedIO488  
  
    Set psa.IO = session  
  
    ' Put the instrument in basic mode  
    psa.WriteString ":INST BASIC"  
    ' Reset basic mode  
    psa.WriteString "*RST"  
    ' Put the instrument into the Waveform measurement  
    psa.WriteString ":INIT:WAV"  
    ' Activate the Option 122 wideband mode  
    psa.WriteString "WAV:IFP WIDE"  
  
End Sub
```

**Step 5.** Enter the appropriate Visa string as described above.

Save the form and project, then run it. A dialog should come up showing you the idn string.

Close that dialog.

Then close the blank program form that will come up after that.

**Step 6.** Go back to the form, and add a button.

That is, click-and-hold on the button icon on the left. Then drag the mouse over to the form to create the button.

In the properties window, the button caption will be highlighted.  
Change it to **Take Sweep**.

**Step 7.** Now add the command sequence below:

```
Private Sub Command1_Click()

    Dim opcValue As String
    Dim dataArray
    Dim tracePoints As Integer
    Dim freq As Double

    freq = 1250000000#

    psa.WriteString ":INIT:CONT OFF" ' Single Sweep
    psa.WriteString ":DISP:ENAB 0" ' Turn off the display
    psa.WriteString ":WAV:NCPT 1" ' Don't compute dBm
    psa.WriteString ":FEED:DATA INP" ' In case a deep capture has been done
    psa.WriteString ":CAL:AUTO OFF" ' Don't allow alignments when busy

    psa.WriteString ":FREQ:CENT " & freq ' Center frequency
    psa.WriteString ":WAV:SWE:TIME 125e-6" ' Acquisition Time
    psa.WriteString ":WAV:SRAT 50e6" ' Sample Rate
    psa.WriteString ":WAV:TRIG:SOUR IMM" ' Free run trigger

    ' Trigger the sweep and wait for it to complete
    psa.WriteString ":INIT;*OPC?"
    opcValue = psa.ReadString()

    ' Read the trace back
    psa.WriteString ":FORM:BORD NORM"
    psa.WriteString ":FORM REAL, 32"
    psa.WriteString ":CALC:DATA0?"
```

```
dataArray = psa.ReadIEEEBlock(BinaryType_R4, True, True)

' Calculate how many complex pairs came back
tracePoints = (UBound(dataArray) - LBound(dataArray) + 1) / 2

' Sequence through array, saving data to file and calculating min and max
Dim dataMin As Single
Dim dataMax As Single
Dim magArray() As Single
ReDim magArray(tracePoints)
Dim tmp As Single
Dim idx As Integer
Dim cnt As Integer

idx = LBound(dataArray)
dataMin = dataArray(idx) * dataArray(idx) + dataArray(idx + 1) * dataArray(idx + 1)
dataMax = dataMin

Dim fs, f
Dim filename As String
filename = "c:\temp\datafile.csv"
Set fs = CreateObject("Scripting.FileSystemObject")
Set f = fs.CreateTextFile(filename, 1)

For cnt = LBound(dataArray) To LBound(dataArray) + tracePoints - 1
    idx = cnt - LBound(dataArray)
    ' Find mag square
    tmp = dataArray(2 * idx) * dataArray(2 * idx) + _
        dataArray(2 * idx + 1) * dataArray(2 * idx + 1)
    magArray(cnt) = tmp
    If tmp < dataMin Then dataMin = tmp
    If tmp > dataMax Then dataMax = tmp
```



```
' write to file
f.Write dataArray(2 * idx) & ", " & dataArray(2 * idx + 1) & Chr(10)
Next cnt
f.Close

' Note on power scaling. Data from PSA is I/Q data in Volts
'   power = V^2/R - real voltage
' But we have I/Q volts, which introduces a factor of two
'   power = (Vi^2 + Vq^2) / (2 R) Watts
'
' Power, dBm = 10 log10(mW) = 10 log10 [ (Vi^2 + Vq^2) * 1000 / ( 2 R ) ]
' In this case, R is 50 ohms, so we get 10log10(1000/100) = 10, so
' Power, dBm = 10 + 10 log10(Vi^2 + Vq^2)
'           = 10 + 10 * ln(Vi^2+Vq^2)/ln(10)
MsgBox "Data acquired at " & freq / 1000000000# & " GHz" & Chr(10) & _
      "Data is in " & filename & Chr(10) & _
      "The max value is " & 10 * Log(dataMax) / Log(10) + 10, _
      vbOKOnly, "Sweep Done"

' Let instrument sweep with front panel live
psa.WriteString ":INIT:CONT ON"
psa.WriteString ":DISP:ENAB 1"
psa.WriteString ":WAV:NCPT 0"
psa.WriteString ":CAL:AUTO ON" ' Let alignment happen if needed
```

End Sub

**Step 8.** Save the form and project, then run it.

Click on the **Take Sweep** button, and the program will take a sweep. (You will not see anything on the instrument display until after you click OK on the end-of-sweep dialog, because the display has been turned off for speed.)

You can look at the sweep results by loading the file c:\tmp\datafile.csv

into a Microsoft Excel spreadsheet.

---

**NOTE** The c:\tmp directory must exist for the program to run.

---

**Step 9.** To do a deep data capture, return to the form view and add a second button.

Change the button caption to **Deep Capture**.

Next, add a text label.

Leave the caption and the name at the defaults. Then, return to the code view and paste in the following code:

```
Private Sub Command2_Click()

    Dim opcValue As String
    Dim dataArray
    Dim tracePoints As Integer
    Dim captureTime As Double ' in seconds
    Dim numRecords As Integer

    captureTime = 0.0025 ' 2.5 mseconds

    ' Assume set up has been all done before - we just are doing deep acquisition
    psa.WriteString ":INIT:CONT OFF"
    psa.WriteString ":DISP:ENAB 0"
    psa.WriteString ":WAV:NCPT 1"
    psa.WriteString ":CAL:AUTO OFF" ' Don't allow alignments when busy

    ' Set the capture time
    psa.WriteString ":TCAP:TIME " & captureTime

    ' Launch the capture and wait for it
    psa.WriteString ":INIT:TCAP;*OPC?"
    opcValue = psa.ReadString()

    ' Find out how many records actually stored
```

```
psa.WriteString (":TCAP:LREC?")
numRecords = psa.ReadNumber(ASCIIType_I4)

' Prepare to read many traces back
psa.WriteString ":FORM:BORD NORM"
psa.WriteString ":FORM REAL, 32"
psa.WriteString ":TCAP:NREC 1" ' Make sure we start at first record

Dim record As Integer
Dim cnt As Integer
Dim idx As Integer
Dim fs, f
Dim filename As String

filename = "c:\temp\datafile.csv"
Set fs = CreateObject("Scripting.FileSystemObject")
Set f = fs.CreateTextFile(filename, 1)

For record = 1 To numRecords
    Label1.Caption = " Reading & saving record number " & record & " of " & numRecords
    DoEvents
    ' Transfer the next record
    psa.WriteString ":READ:WAV0?"
    dataArray = psa.ReadIEEEBlock(BinaryType_R4, True, True)
    tracePoints = (UBound(dataArray) - LBound(dataArray) + 1) / 2
    ' Append to file
    For cnt = LBound(dataArray) To LBound(dataArray) + tracePoints - 1
        idx = cnt - LBound(dataArray)
        f.Write dataArray(2 * idx) & ", " & dataArray(2 * idx + 1) & Chr(10)
    Next cnt
Next record
f.Close
```

```
Label1.Caption = "Done"
```

```
MsgBox "Capture time " & captureTime * 1000 & " ms" & Chr(10) & _  
    "Number of records " & numRecords & Chr(10) & _  
    "Data is in " & filename, _  
    vbOKOnly, "Deep Capture Done"
```

```
' Let instrument sweep with front panel live  
psa.WriteString ":FEED:DATA INP"      ' cancel deep capture playback  
psa.WriteString ":INIT:CONT ON"  
psa.WriteString ":DISP:ENAB 1"  
psa.WriteString ":WAV:NCPT 0"  
psa.WriteString ":CAL:AUTO ON"      ' Let alignment happen if needed  
End Sub
```

**Step 10.** Save the project and the form and run it.

You have to take a sweep first, before doing a deep capture. So, click **Take Sweep** and confirm the OK dialog. Then click **Deep Capture**.

The data capture can take a while, so the program updates a text label each time a record is loaded.

The capture is saved as one long continuous time record in the file c:\tmp\datafile.csv. Microsoft Excel cannot load the complete file for a deep capture (too many points), but Matlab can.

---

## 3 Key Reference

This chapter provides detailed descriptions of the keys used to set up and make Basic Mode measurements, including **Mode Setup**, **Meas Setup**, and **MEASURE**. Keys that allow you to see different presentations of the measurement results are also described, including **Trace/View**, and **Display**, showing the associated screens.

## Instrument Front Panel Highlights

The most commonly used function keys on the PSA front panels are located as shown in the illustrations below. The operation of the keys is briefly explained on the following page. Refer to your User's Guide for complete details on all keys.

**Figure 3-1 Selected PSA Series Front Panel Feature Locations**

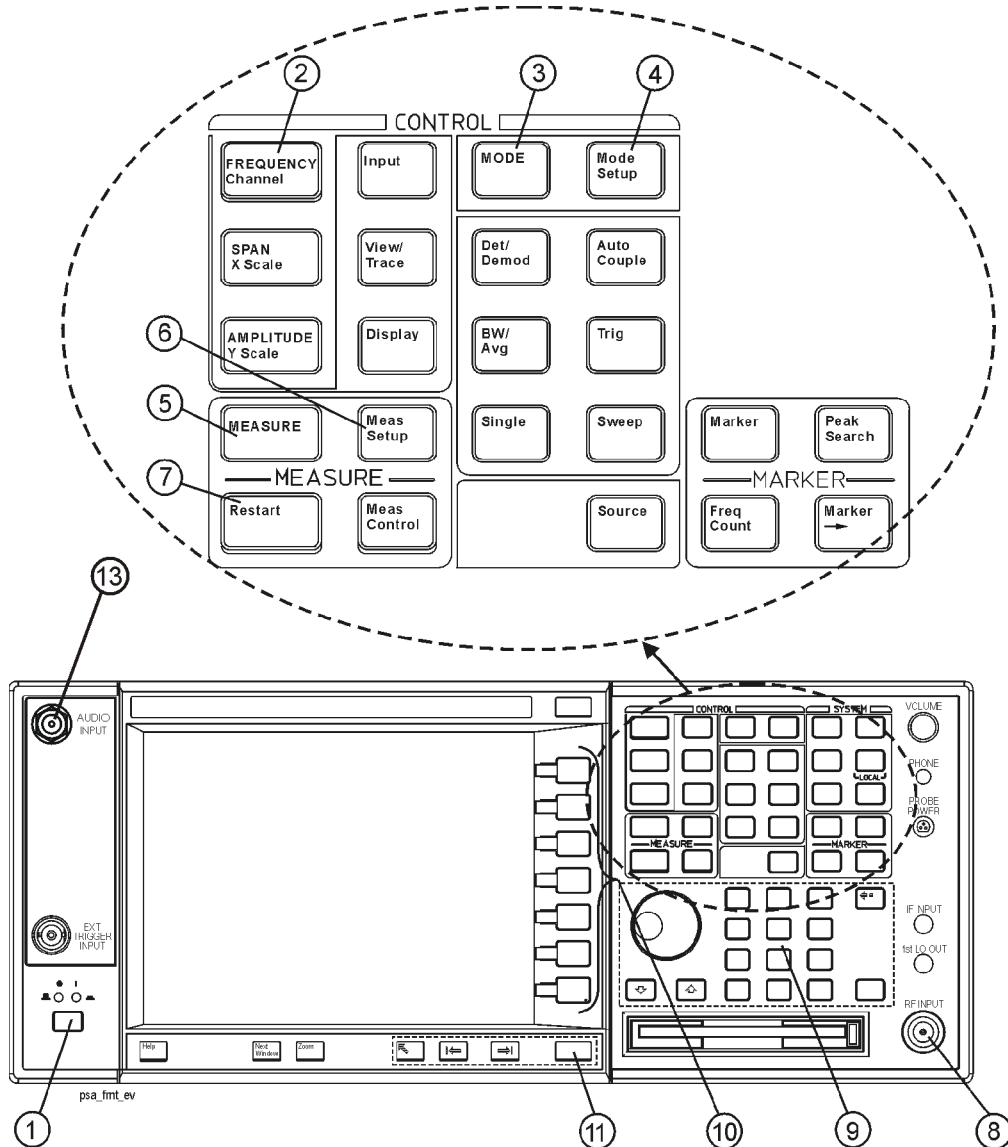

## Selected PSA Front-Panel Features

1. The **On/Off** switch toggles the AC Line power between On and Standby. A green LED will light when the instrument is On. When energized in the standby mode, a yellow LED is lit above the switch.
2. **FREQUENCY Channel** accesses a key menu to set the analyzer center frequency in units of Hz, kHz, MHz, or GHz, or by channel number. These parameters apply to all measurements in the current mode.
3. **MODE** accesses a key menu to select one of the measurement personalities installed in the instrument. Each mode is independent from all other modes.
4. **Mode Setup** accesses a key menu that sets parameters specific to the current mode and can affect all measurements within that mode.
5. **MEASURE** accesses a display key menu to initiate one of the various measurements that are specific to the current mode.
6. **Meas Setup** accesses the menus of test parameters that are specific to the current measurement.
7. **Restart** causes a measurement to start again from the initial process according to the current measurement setup parameters.
8. **RF INPUT** port: Type N connector for the E4443A, E4445A, and E4440A PSAs. It is a 2.4 mm connector on the E4446A, and E4447A, and E4448A PSAs. It is a 3.5 mm connector on all E4440A PSAs with Opt BAB. The maximum input power level is shown next to the port.
9. The **Data Entry** keypad is used to enter numeric values. Keypad entries are displayed in the active function area of the screen and become valid for the current measurement upon pressing the **Enter** key or selecting a unit of measurement, depending on the parameter.
10. The Display Menu keys allow you either to activate a feature or to access a more detailed sub-menu. An arrow on the right side of a softkey label indicates that the key has a further selection menu. The active menu key is highlighted, however, grayed-out keys are currently unavailable for use or only show information. If a menu has multiple pages, successive pages are accessed by pressing the **More** key located at the bottom of the menu.
11. **Return** allows you to exit the current menu and display the previous menu. If you are on the first page of a multi-page menu (a menu with **(1 of 3)** for example), the **Return** key will exit from that menu. When you activate another measurement, the return list is cleared. The **Return** key will not return you to a previously activated mode, nor will it alter any values you have entered in previous menus.
12. **Baseband I/Q Inputs** (E4406A Option B7C only) allows you to analyze signals at baseband frequencies.
13. **BNC Audio Input** (Option 107) provides a 100 kOhm input for audio measurements. The frequency range is 20 Hz to 250 kHz. The safe input level is 7 Vrms or 20 V DC.

---

## Front Panel Keys

**NOTE** Only front panel keys affected by selection of Basic mode are described here. These key settings affect all of the measurements available under the **MEASURE** key.

For information about the measurements and their setups, see the individual measurement key descriptions in this chapter.

For a description of all front panel keys, see the PSA Series User's and Programmer's Reference.

---

## FREQUENCY Channel Key Menu

Key path: **FREQUENCY Channel**

**NOTE** **FREQUENCY Channel** settings apply to all measurements in the mode.

- **Center Freq** - Selects a frequency that corresponds to the desired RF channel to be measured. This is the current instrument center frequency.

## Span X Scale Key Menu

- **Span** - Modifies the frequency span. The range is 10.000 Hz to 10.000 MHz with 1 Hz resolution, depending on the **Res BW** setting. Changing the span causes the resolution bandwidth to change automatically, and will affect data acquisition time. The **Span** key is also accessible under the **Meas Setup** menu.
- **IF Path** - Only available if you have Option B7J and Option 122 or 140 installed, and you are using the Spectrum measurement with the Spectrum display. It selects either the standard narrowband IF hardware path (10 MHz) or the wideband hardware path (80 or 40 MHz).
- **Scale/Div** - Only available in the Spectrum measurement with the IQ Waveform display selected. It sets the horizontal scale by changing a time value per division. The range is 1.00 ns to 1.00 s per division. The default setting is 18.8 ms per division. However, since the **Scale Coupling** default is **On**, this value is automatically determined by the measurement results. When you set a value manually, **Scale Coupling** automatically changes to **Off**.
- **Ref Value** - Only available in the Spectrum measurement with the IQ Waveform display selected. It sets the reference value ranging from -1.00 to 10.0 s. The default setting is 0.00 s. However, since the **Scale Coupling** default is **On**, this value is automatically determined by the



measurement results. When you set a value manually, **Scale Coupling** automatically changes to **Off**.

- **Ref Position** - Only available in the Spectrum measurement with the IQ Waveform display selected. It sets the reference position to either **Left**, **Ctr** (center) or **Right**. The default setting is **Left**.
- **Scale Coupling** - Only available in the Spectrum measurement with the IQ Waveform display selected. It toggles the scale coupling function between **On** and **Off**. The default setting is **On**. Upon pressing the **Restart** front-panel key or **Restart** softkey under the **Meas Control** menu, this function automatically determines the scale per division and reference values based on the measurement results. When you set a value to either **Scale/Div** or **Ref Value** manually, **Scale Coupling** automatically changes to **Off**.

## MEASURE Key Menu

Key path: **MEASURE**

- **Spectrum (Freq Domain)** - Press this key to make frequency domain spectrum measurements. The following windows are available:
  - Spectrum graph with semi-log graticules and I/Q waveform graph with linear graticules
- **Waveform (Time Domain)** - Press this key to make time domain waveform measurements. The following windows are available:
  - Signal Envelope graph with semi-log graticules and summary data
  - I/Q waveform graph and summary data
- **CCDF** - Press this key to make power statistics measurements. The following windows are available:
  - The tested CCDF curve shown on the right-hand side of the display
  - The average power and the power statistics data on the left-hand side of the display

## Meas Control Key Menu

Key path: **Meas Control**

- **Restart** - Press this key to repeat the current measurement from the beginning, while retaining the current measurement settings. When pressed, the scale coupling function is activated for an appropriate display to the current input signal level. This is equivalent to the **Restart** front panel key.

- **Measure** - Press this key (not to be confused with the **MEASURE** front panel key which has a different function) to toggle the measurement state between **Single** and **Cont** (continuous). When set to **Single**, the measurement will continue until it has reached the specified number of averages set by the average counter. When set to **Cont**, the measurement will run continuously and execute averaging according to the current average mode, either repeat or exponential. The default setting is **Cont** for most measurements, but the Code Domain and Power Stat CCDF measurements have **Single** as the default.
- **Pause** - Press this key to pause the current measurement until you reactivate the measurement. Once toggled, the label of the **Pause** key changes to read **Resume**. The **Resume** key, once pressed, continues the active measurement from the point at which it was paused.
- **Fill Capture** - (For PSA Basic mode Option 122 or 140 only.) If you are in single sweep/measurement when you first switch to the wideband IF path, the **Fill Capture** key will be grayed out. This feature is not available until you initiate the measurement process. You need to press the **Single** key or change to continuous sweep to access these functions.

Press this key to save the current input signal data to an internal buffer. The data capture uses the current measurement setup. Data will continue to be stored until the buffer is full, or the data reaches the limitations set using the **Capture Setup** keys. While filling, the key changes to **Cancel Fill** so you can stop collecting data at any time. When the buffer is full, the input data source selection will be automatically changed to **Recorded Data** and the data will begin playing back.

- **Capture Setup** - (For PSA Basic mode Option 122 or 140 only.)  
Accesses keys to set or view settings for the captured data buffer. If you are in single sweep/measurement when you first switch to the wideband IF path, the **Capture Setup** key will be grayed out. This feature is not available until you initiate the measurement process. You need to press the **Single** key or change to continuous sweep to access these functions.
  - **Capture Time** - Sets the length of time that data coming from the input will be saved into the data buffer. In the Spectrum measurement the maximum time available changes depending on the resolution bandwidth and other instrument settings. (In Waveform measurements, it's the IF bandwidth.)
- **Playback Setup** - (For PSA Basic mode Option 122 or 140 only.)  
Accesses keys to set or view settings for playing back the data that is in the data capture buffer. The data was captured using **Fill Capture** under the **Meas Control** key. If you are in single sweep/measurement when you first switch to the wideband IF path, the **Playback Setup** key will be grayed out. This feature is not available until you initiate

the measurement process. You need to press the **Single** key or change to continuous sweep to access these functions.

- **Start Record** - Selects the first data record that will be routed to the input to be re-measured during playback.
- **Stop Record** - Selects the last data record that will be routed to the input to be re-measured during playback.
- **Start Time** - This key is for information only. It shows the start time of the captured data that corresponds with the first data record.
- **Stop Time** - This key is for information only. It shows the stop time of the captured data that corresponds with the last data record.

## Mode Setup Key Menu

Key path: **Mode Setup**

### Input Key Menu

Key Path: **Mode Setup, Input**

---

#### NOTE

You can also access this menu from the **Input/Output** front panel key.

- **Input Port** - Allows you to access the menu to select one of the signal input ports as follows:
  - **RF** - Measures an RF signal supplied to the front panel RF input port.
  - **Amptd Ref (f=50 MHz)** - Allows you to measure the 50 MHz reference signal to calibrate the instrument.
  - **IF Align** - Allows you to configure the IF alignment signal. The RF path is manually switched to bring in the internal alignment signal.
  - **WB Align (f=300MHz)** - (For PSA Option 122 or 140 only.) Selects the internal wideband IF alignment signal.
- **Data Source** - (For PSA Option 122 or 140 only.) Lets you select Input to use the normal front panel input to make measurements. Selecting Input clears the existing captured data from memory. The **Recorded** setting indicates that the current displayed data is from a previous data capture. You cannot select the recorded data with this key. You must use the **Fill Capture** key under **Measure**.
- **Microwave Preselector** - (For PSA Option 123) Switches off the microwave preselector (frequencies >3GHz). This allows all the frequency mixing images to be displayed, but it improves the amplitude accuracy due to drift.
- **Input Atten** - Controls the internal input attenuator setting. The electronic attenuator range is 0 to 40 dB with 1 dB resolution. The **Input Atten** key reads out the value that is used for the current measurement. If more than one input attenuator value is used in a single measurement, the value used at the carrier frequency will be displayed. The **Input Atten** setting is coupled to the **Max Total Pwr** setting.

For PSA Option 122 or 140, if you are using the wideband IF path, the mechanical attenuator is used. It has a range of 0 to 70 dB in 2 dB increments.

When you use the internal preamplifier, **Int Preamp**, the electronic attenuator selections using the **Input Atten** key are not available, and the key is grayed out. Use the mechanical attenuator under **Attenuator**.

- **Ext RF Atten** - Enters the external attenuation values. The **Ext RF Atten** settings is coupled to the **RF Input Range** setting. This allows the instrument to display the measurement results referenced to the output of the UUT.
- **IF Align Signal** - Accesses the following menu to select one of the signals to be used for IF alignment:
  - Signal Rate** - Sets a value to be used for dividing the fundamental frequency of 468.75 kHz. The value ranges from 0 to 12 as the power of 2.
  - Signal Amptd** - Sets an amplitude value to be applied to the digital analog converter, for the IF alignment signal. The value ranges from 0 to 4095. This functionality is not available if the PSA Option 122 or 140 wideband IF path is selected.
  - Signal Type** - Accesses the following menu to select one of the signal types:
    - CW** - Sets the IF alignment signal to CW.
    - Comb** - Sets the IF alignment signal to comb wave.
    - Pulse** - Sets the IF alignment signal to pulse wave.

<b>Input Default Settings</b>	
Input Port	RF
Input Atten	0.00 dB
Ext RF Atten: MS BTS	0.00 dB 0.00 dB
Int Preamp	OFF
Attenuator	0 dB
IF Align Signal: Signal Rate Signal Amptd Signal Type	0; = 468.75 kHz DAC 500 CW

## Trigger Key Menu

Key Path: **Mode Setup, Trigger, <trigger type>**

---

**NOTE**

---

The actual trigger source is selected individually for each measurement under the **Meas Setup** key.

- **RF Burst, Video (Envlp), Ext Front, Ext Rear**- Pressing any one of these trigger keys accesses the following triggering condition setup menu. This menu is used to specify the **Delay, Level** and **Slope** settings for each trigger source as follows:

- **Delay** - Enters a numerical value to modify the trigger delay time. The range is  $-100.0$  to  $+500.0$  ms with  $1\ \mu\text{s}$  resolution. For trigger delay use a positive value, and for pre-trigger use a negative value.

- **Level** - Enters a numerical value to adjust the trigger level depending on the trigger source selected.

- For **RF Burst**, the key label reads as **Peak Level**. The RF level range is  $-25.00$  to  $0.00$  dB with  $0.01$  dB resolution, relative to the peak RF signal level. The realistic range can be down to  $-20$  dB.

- For **Video (Envlp)**, the video level range is  $-200.00$  to  $+50.00$  dBm with  $0.01$  dB resolution at the RF input. The realistic range can be down to around  $-50$  dBm depending on the noise floor level of the input signal.

- For **Ext Front** or **Ext Rear**, the level range is  $-5.00$  to  $+5.00$  V with  $1$  or  $10$  mV resolution.

- **Slope** - Toggles the trigger slope between **Pos** at the positive-going edge and **Neg** at the negative-going edge of the burst signal.

- **Trig Holdoff** - Sets the period of time before the next trigger can occur. The range is  $0.000\ \mu\text{s}$  to  $500.0$  ms with  $1\ \mu\text{s}$  resolution.

For Option 122 or 140: When the wideband path is selected, the trigger holdoff is the minimum time that must occur between trigger events before a trigger is accepted. For example, a rising edge external trigger with a  $10$  ms holdoff will not trigger until at least  $10$  ms has passed during which no rising edges have occurred.

This Option 123 definition changes slightly for negative slope video triggers. For this case the instrument waits until it sees a time interval *following* the trigger event that is free of additional trigger events. This lets you trigger on the falling edge of a burst that may contain trigger events.

- **Auto Trig** - Specifies a time for a trigger timeout and toggle the auto trigger function between **On** and **Off**. The range is  $1.000$  ms to  $1.000$

ks with 1  $\mu$ s resolution. If no trigger occurs by the specified time, a trigger is automatically generated.

- **Frame Timer** - Accesses the menu to manually control the frame timer:
  - **Period** - Sets the period of the frame clock. The range is 0.000 ns to 559.0000 ms with 1 ns resolution.
  - **Offset** - Sets the offset of the frame clock. The range is 0.000 to 10.00 s with 100 ns resolution over 1.000  $\mu$ s range.
  - **Reset Offset Display** - Displays the measurement without any offset of the frame clock.
  - **Sync Source** - Accesses the menu to select one of the sources to be synchronized with.

For Option 122 or 140: The frame trigger will wait for, and sync with, the first external trigger that is received after sync is turned off. After the sync is received the frame trigger stays locked to that event, ignoring any later triggers. The instrument will only resync if the measurement settings are changed or if an alignment occurs.

- Off** - Turns the synchronizing source off for asynchronous tests.
- RF Burst (Wideband)** - Selects the RF burst signal as the synchronizing source. (Not available with Option 122 or 140 when using the wideband IF path.)
- Ext Front** - Selects the external input signal from the front panel input port as the synchronizing source. With Option 122 or 140, you can use the external front trigger setup menu to change the trigger level or delay.
- Ext Rear** - Selects the external input signal from the rear panel input port as the synchronizing source. With Option 122 or 140, you can use the external rear trigger setup menu to change the trigger level or delay.

<b>Trigger Default Settings</b>	
RF Burst: Delay Peak Level Slope	0.000 $\mu$ s -6.00 dB Pos
Video (Envlp): Delay Level Slope	0.000 $\mu$ s -6.00 dBm Pos

<b>Trigger Default Settings</b>	
Ext Front: Delay Level Slope	0.000 $\mu$ s 2.00 V Pos
Ext Rear: Delay Level Slope	0.000 $\mu$ s 2.00 V Pos
Trig Holdoff	0.000 ms
Auto Trig	100.0 ms; Off
Frame Timer: Period Offset Sync Source	26.666667 ms 0.000 ms Off



---

## Spectrum (Frequency Domain) Keys

---

**NOTE** You must have selected **Spectrum** under the, **MEASURE** menu to access these menus.

---

### Meas Setup Key Menu

Key Path: **Meas Setup**

- **Span** - Modifies the frequency span. The range is 10 Hz to 10 MHz with 1 Hz resolution, depending on the **Res BW** setting. Changing the span causes the resolution bandwidth to change automatically, and will affect data acquisition time. For PSA Option 122 wideband operation, the maximum span is 80 MHz. For PSA Option 140 wideband operation, the maximum span is 40 MHz.
- **Res BW** - Sets the resolution bandwidth for the FFT, and toggles its mode between **Auto** and **Man** (manual). If set to **Auto**, the resolution bandwidth is set to **Span/50** (2% of the span). If set to **Man**, you can enter a value ranging from 100.0 mHz to 3.00000 MHz. A narrower bandwidth will result in a longer data acquisition time.
- **Wideband Setup** (PSA Options 122 and 140 only.) configures the wideband hardware path.
  - **Wideband IF Gain** - Sets the gain for the wideband IF path in 2 dB steps from - 12 to +12 dB. You must have selected **IF Path Wide**. Increasing the gain can increase the amplitude of small signals as long as you don't overdrive the hardware. Wideband gain should usually be adjusted after setting the input attenuation.
  - **Wideband Filtering** - Accesses the keys to configure the optional channel filter. The default is no filtering.
    - Filter Type** - Selects **None** for no filtering, or **Raised Cosine**, **RRC** (root-raised cosine), **Nyquist**, **Root Nyquist**, and **Gaussian**.
    - Filter Alpha** - Selects the filter alpha.
    - Filter BW** - Selects the filter bandwidth. Bandwidth is not entered as a frequency. The value is entered as a ratio of the current instrument sampling rate (that is, BW/sample rate).
  - **Wideband Advanced** - These keys are only for the PSA Option 122 or 140 in wideband operation. Accesses the advanced settings for the wideband IF hardware path.

---

**NOTE** Parameters under the **Wideband Advanced** key seldom need to be changed. Any changes from the default advanced values may result in invalid measurement data.

---

- ❑ **ADC Corr** - Turning corrections on performs an ADC calibration to reduce the spectral image and applies the corrections.
- ❑ **IF Flat Corr** - Turns IF flatness corrections on and off for the Option 122 or 140 wideband IF. This control is independent of the narrowband IF flatness control.
- ❑ **Analog Filter** - Manually selects the 80 MHz (Option 122), 40 MHz (Option 140), or 36 MHz anti-alias filter, which overrides the automatic selection of the bandwidth.
- ❑ **WB ADC Dither** - Toggles the ADC dither function on/off. The “ADC dither” refers to the introduction of noise to the digitized steps of the analog-to-digital converter; the result is an improvement in amplitude accuracy. The wideband dither control does not affect the ADC dither in the narrowband IF path.
- ❑ **FFT Window** - Accesses the following selection menu. Unless you are familiar with FFT windows, use the flat top filter (the default filter).
  - **Flat Top** - Selects this filter for best amplitude accuracy by reducing scalloping error.
  - **Uniform** - Select this filter to have no window active by using the uniform setting.
  - **Hanning** - Press this key to activate the Hanning filter.
  - **Hamming** - Press this key to activate the Hamming filter.
  - **Gaussian** - Press this key to activate the Gaussian filter with the roll-off factor (alpha) of 3.5.
  - **Blackman** - Press this key to activate the Blackman filter.
  - **Blackman Harris** - Press this key to activate the Blackman Harris filter.
  - **K-B 70dB/90dB/110dB (Kaiser-Bessel)** - Select one of the Kaiser-Bessel filters with sidelobes at – 70, – 90, or – 110 dBc.
- ❑ **FFT Size** - Accesses the menu to change the following parameters:
  - **Length Ctrl** - Toggles the FFT and window length setting function between **Auto** and **Man** (manual).
  - **Min Pts in RBW** - Sets the minimum number of data points that will be used inside the resolution bandwidth. The range is 0.10 to 100.00 points with 0.01 resolution. This key is grayed out if **Length Ctrl** is set to **Man**.
  - **Window Length** - Enters the FFT window length in the

number of capture samples, ranging from 8 to 1048576. This length represents the actual quantity of I/Q samples that are captured for processing by the FFT (“Capture Time” is the associated parameter shown on the screen). This key is grayed out if **Length Control** is set to **Auto**.

- **FFT Length** - Enters the FFT length in the number of captured samples, ranging from 8 to 1048576. The FFT length setting is automatically limited so that it is equal to or greater than the FFT window length setting. Any amount greater than the window length is implemented by zero-padding. This key is grayed out if **Length Control** is set to **Auto**.

- **Average**

- **Avg Number** - Allows you to select whether averages are made or not, and allows you to change the number of N averages that are made.
- **Avg Mode** - Allows you to choose either **Exp** (exponential) or **Repeat**. This selection only affects the averaging result after the number of N averages is reached. The N is set using the **Avg Number** key.
  - Normal averaging: Normal (linear) averaging is always used until the specified number of N averages is reached. When the **Measure** key under **Meas Control** is set to **Single**, data acquisition is stopped when the number of N averages is reached, thus **Avg Mode** has no effect in the single measurement mode.
  - Exp** - Exponential averaging: When **Measure** is set to **Cont**, data acquisition will continue indefinitely. Exponential averaging is used with a weighting factor of N (the displayed count of averages stops at N). Exponential averaging weights new data more heavily than old data, which allows tracking of slow-changing signals. The weighting factor N is set using the **Avg Number** key.
  - Repeat** - Repeat averaging: When **Measure** is set to **Cont**, data acquisition will continue indefinitely. After the number of N averages is reached, all previous result data is cleared and the average count displayed is set back to 1. This is equivalent to being in **Measure Single** and pressing the **Restart** key each time the single measurement finishes.

- **Avg Type** - Accesses the menu of the following average types only for making Spectrum (Frequency Domain) and Waveform (Time Domain) measurements:
  - Pwr Avg (RMS)** - Executes the true power averaging which is calculated by averaging the rms voltage. This is the most accurate type.
  - Log-Pwr Avg (Video)** - Simulates the traditional spectrum analyzer type of averaging by calculating the log of the power. This type of averaging will underestimate the power when the signal is noise-like.
  - Voltage Avg** - Executes voltage averaging.
  - Maximum** - Captures peak voltage data. Simulates the traditional spectrum analyzer peak hold function.
  - Minimum** - Captures the minimum voltage data, similar to the maximum function.
- **Time Avg Num** - Changes the number of time averages to be made when using the Option 122 or 140 wideband hardware (PSA only). This averaging requires a frame trigger and is much faster than the standard averaging. This hardware averaging is done on the complex voltage time trace data before any measurement application averaging is done. Both types of averaging can be done on the same measurement data.

When time averaging is being done, each trace update represents N fresh data acquisitions averaged together, where N is the number of averages. You cannot access the individual time records that are being averaged in the hardware averager.

**NOTE**

If your triggering is not set correctly, the signal can be averaged away to nothing. A HW Average message is displayed to show that the averaging is on.

- **Trig Source**

Key path: **Meas Setup, Trig Source**

**NOTE**

Changing the selection in the **Trig Source** menu alters the trigger source for the selected measurement only.

- **Free Run (Immediate)** - A trigger occurs at the time the data is requested, completely asynchronous with the RF or IF signal.
- **Video (Envlp)** - An internal IF envelope trigger that occurs at the absolute threshold level of the IF signal level.
- **RF Burst (Wideband)** - An internal wideband RF burst trigger that has automatic level control for burst signals. It triggers at the

level that is set relative to the peak RF signal (12 MHz bandwidth) input level. (Not available for Option 122 or 140 when using the wideband IF path.)

- **Ext Front** - Activates the front panel external trigger input (**EXT TRIGGER INPUT**) port. The external signal must be between – 5.00 and +5.00 V with 1 or 10 mV resolution.
- **Ext Rear** - Activates the rear-panel external trigger input (**TRIGGER IN**) port. The external signal must be between – 5.00 and +5.00 V with 1 or 10 mV resolution.
- **Frame** - Uses the internal frame clock to generate a trigger signal. The clock parameters are controlled under the **Mode Setup** key or the measurement firmware, but not both. Refer to the specific measurement section for details.
- **Line** - Sets the trigger to the internal line mode. Sweep triggers occur at intervals synchronous to the line frequency. See the specific measurement section for details.
- **IF Path** - (Only for PSA with both Option B7J and either Option 122 or 140 installed.) Selects either the standard narrowband IF hardware path or the wideband hardware. If only Option B7J is installed, only the narrowband hardware is used. If only Option 122 or 140 is installed, the wideband digitizer is used.
- **Restore Meas Defaults** - Presets only the settings that are specific to the selected measurement by pressing **Meas Setup, More, Restore Meas Defaults** - This will set the measure setup parameters, for the currently selected measurement only, to the factory defaults.
- **(Narrowband) Advanced** - Accesses the menu to change the following parameters.

---

**NOTE**

The advanced features should be used only if you are familiar with their operation. Changes from the default values may result in invalid data.

The **Narrowband** key is only present if you have both Option B7J and Option 122 or 140 installed. Parameters that are under the **(Narrowband) Advanced** key only affect the standard narrow band IF path. The wideband IF advanced functions are found under the **Wideband Advanced** key.

- **Pre-ADC BPF** - Toggles the pre-ADC bandpass filter function between **On** and **Off**. The pre-ADC bandpass filter is useful for rejecting nearby signals, so that sensitivity within the span range can be improved by increasing the ADC range gain.

- **Pre-FFT Fitr** - Toggles the pre-FFT filter between **Flat** (flat top) and **Gaussian**. The pre-FFT filter defaults to a flat top filter which has better amplitude accuracy. The Gaussian filter has better pulse response.
- **Pre-FFT BW** - Toggles the pre-FFT bandwidth function between **Auto** and **Man** (manual). The pre-FFT bandwidth filter can be set between 1 Hz and 10 MHz. If set to **Auto**, this pre-FFT bandwidth is nominally 50% wider than the span. This bandwidth determines the ADC sampling rate.
- **FFT Window** - Accesses the following selection menu. Unless you are familiar with FFT windows, use the flat top filter (the default filter).
  - Flat Top** - Select this filter for best amplitude accuracy by reducing scalloping error.
  - Uniform** - Select this filter to have no window active by using the uniform setting.
  - Hanning** - Press this key to activate the Hanning filter.
  - Hamming** - Press this key to activate the Hamming filter.
  - Gaussian** - Press this key to activate the Gaussian filter with the roll-off factor (alpha) of 3.5.
  - Blackman** - Press this key to activate the Blackman filter.
  - Blackman Harris** - Press this key to activate the Blackman Harris filter.
  - K-B 70dB/90dB/110dB (Kaiser-Bessel)** - Select one of the Kaiser-Bessel filters with sidelobes at  $-70$ ,  $-90$ , or  $-110$  dBc.
- **FFT Size** - Accesses the menu to change the following parameters:
  - Length Ctrl** - Toggles the FFT and window length setting function between **Auto** and **Man** (manual).
  - Min Pts in RBW** - Sets the minimum number of data points that will be used inside the resolution bandwidth. The range is 0.10 to 100.00 points with 0.01 resolution. This key is grayed-out if **Length Ctrl** is set to **Man**.
  - Window Length** - Enters the FFT window length in the number of capture samples, ranging from 8 to 1048576. This length represents the actual quantity of I/Q samples that are captured for processing by the FFT (“Capture Time” is the associated parameter shown on the screen). This key is grayed-out if **Length Control** is set to **Auto**.
  - FFT Length** - Enters the FFT length in the number of captured samples, ranging from 8 to 1048576. The FFT length setting is automatically limited so that it is equal to or greater than the

FFT window length setting. Any amount greater than the window length is implemented by zero-padding. This key is grayed-out if **Length Control** is set to **Auto**.

- **ADC Range** - Accesses the menu to define one of the following ADC ranging functions:
  - Auto** - Sets the ADC range automatically. For most FFT spectrum measurements, the **Auto** feature should not be selected. An exception is when measuring a signal which is “bursty”, in which case auto can maximize the time domain dynamic range, if FFT results are less important to you than time domain results.
  - Auto Peak** - Sets the ADC range automatically to the peak signal level. **Auto Peak** is a compromise that works well for both CW and burst signals.
  - Auto Peak Lock** - Select this to hold the ADC range automatically at the peak signal level. **Auto Peak Lock** is more stable than auto peak for CW signals, but should not be used for “bursty” signals.
  - Manual** - Accesses the selection menu of values, Zero to +18 dB for PSA (with 14 bit ADC), to set the ADC range level. Also note that manual ranging is best for CW signals.
- **Data Packing** - Selects **Auto** (the default) or the **Short (16 bit)**, **Medium (24 bit)** and **Long (32 bit)** methods of data packing. The short, medium, and long methods are not compatible with all settings and should not be used unless you are familiar with data packing methods. **Auto** is the preferred choice.
  - Auto** - The data packing value most appropriate for current instrument settings is selected automatically.
  - Short (16 bit)** - Select this to pack data every 16 bits.
  - Medium (24 bit)** - Select this to pack data every 24 bits.
  - Long (32 bit)** - Select this to pack data every 32 bits.
- **ADC Dither** - Toggles the ADC dither function between **Auto**, **On**, and **Off**. When set to **Auto** (the default), the ADC dither function will be activated when a narrow bandwidth is being measured, and deactivated when a wide bandwidth is being measured. “ADC dither” refers to the introduction of noise to the digitized steps of the analog-to-digital converter; the result is an improvement in amplitude accuracy. Use of the ADC dither, however, reduces dynamic range by approximately 3 dB.

## Spectrum (Frequency Domain) Keys

- **Decimation** - Toggles the decimation function between **Auto** and **Man**, and to set the decimation value. **Auto** is the preferred setting, and the only setting that guarantees alias-free FFT spectrum measurements. If you are familiar with the decimation feature, you can change the decimation value by setting to **Man**, but be aware that aliasing can result in higher values. Decimation numbers 1 to 1000 describe the factor by which the number of points are reduced. The default setting is 0, which results in no data point reduction. Decimation by 3 keeps every 3rd sample, throwing away the 2 in between.
- **IF Flatness** - Toggles the **IF Flatness** function between **On** and **Off**. If set to **On** (the default), the **IF Flatness** feature causes background amplitude corrections to be performed on the FFT spectrum. The **Off** setting is used for adjustment and troubleshooting of the test instrument.

The following table shows the factory default settings for Spectrum (Frequency Domain) measurements.

**Table 3-1 Spectrum (Frequency Domain) Measurement Defaults**

Measurement Parameter	Factory Default Condition
Trace Display	All
Res BW	200 kHz; Auto - Narrowband path 1.6 MHz; Auto - Wideband path, Option 122 800kHz; Auto - Wideband path, Option 140
Averaging:	
Avg Number	25; On
Avg Mode	Exp
Avg Type	Log-Pwr Avg (Video)
Time Avg Num (Opt. 122 or 140)	1
Trig Source	Free Run (Immediate)
IF Path (requires Option B7J and Option 122 or 140)	Narrow (if both Option B7J and Option 122 or 140 are installed)
Wideband IF Gain (Opt. 122 or 140)	0.00 dB
Wideband Filtering (Opt. 122 or 140)	None
Filter Type	0.30
Filter Alpha	0.50
Filter BW	



**Table 3-1 Spectrum (Frequency Domain) Measurement Defaults**

Measurement Parameter	Factory Default Condition
<b>Spectrum View:</b> SPAN  <b>I/Q Waveform View:</b> Capture time AMPLITUDE Y Scale - Scale/Div	10.000 MHz - Narrowband 80.0 MHz - Wideband, Option 122 40.0 MHz - Wideband, Option 140  10.00 dB
<b>(Narrowband) Advanced</b>	
Pre-ADC BPF Pre-FFT Filter Pre-FFT BW FFT Window FFT Size: Length Control Min Points/RBW Window Length FFT Length ADC Range Data Packing ADC Dither Decimation IF Flatness	10 MHz, On  Flat  10 MHz; Auto  Flat Top (High Amptd Acc)  Auto 3.100000 566 1024  None  Auto  Auto  0; Auto  On
<b>Wideband Advanced</b> (Option 122 or 140 PSA only)	
ADC Correction IF Flatness Corrections WB ADC Dither FFT Window FFT Size: Length Control Min Points/RBW Window Length FFT Length	On  On  On  Flat Top (High Amptd Acc)  Auto 3.100 566 1024

## View/Trace Key Menu

The **View/Trace** key allows you to select the desired view of the measurement from the following. You can use the **Next Window** key to move between the multiple windows (if any) and make it full size by pressing the **Zoom** key.

- **Spectrum** - Provides a combination view of the spectrum graph in parameters of power versus frequency with semi-log graticules, and the I/Q waveform graph in parameters of voltage and time. Changes to frequency span or power will sometimes affect data acquisition. This is equivalent to changing the selected window with the **Next Window** key.

**Figure 3-2 Spectrum Measurement - Spectrum and I/Q Waveform (Default View)**

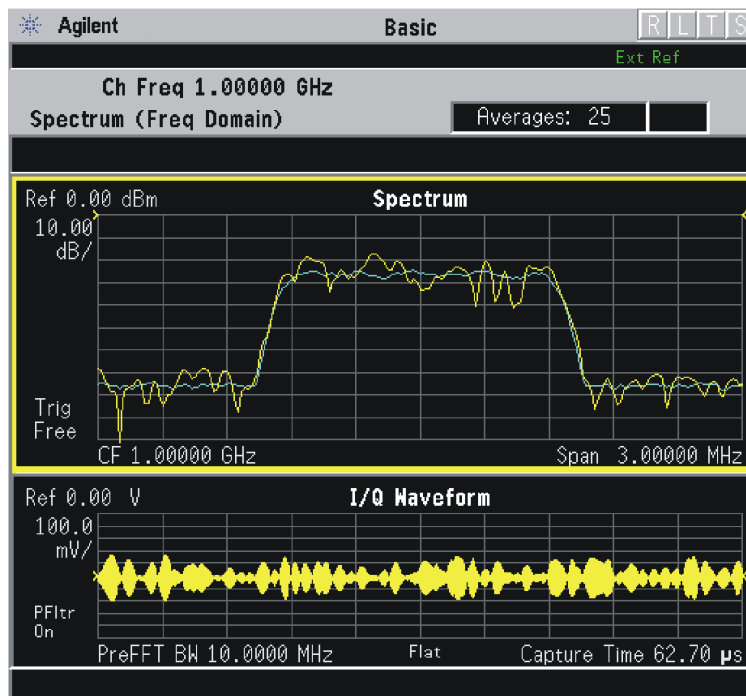

The **Spectrum** measurement result should look like the above figure. The measurement result values are shown in the summary result window.

- **Spectrum (Time Domain) I/Q Waveform** - This graph is shown below the **Spectrum** graph in the default dual-window display. **I/Q Waveform** provides a view of the I/Q waveform in parameters of voltage versus time in linear scale. Changes to sweep time or resolution bandwidth can affect data acquisition. Pressing this button is equivalent to pressing the **Next Window** button on the front panel. Press the **Zoom** key to view this display full-screen.

- **Trace Display** - Press this key to reveal the trace selection menu. The currently selected trace type is shown on the **Trace Display** key.
  - **All** - Views both the current trace and the average trace.
  - **Average** - Views only the average trace (in blue color). See the **Meas Setup, Average** keys to select different types of averaging.
  - **Current** - Views only the trace (in yellow color) for the latest data acquisition.

## SPAN X Scale Key Menu

---

### NOTE

The **Spectrum** window must be active in the **Spectrum** view to access the following **Span X Scale** key menu:

- **Span** - Modifies the frequency span. The range is 10.000 Hz to 10.000 MHz (narrowband path) with 1 Hz resolution, depending on the **Res BW** setting, 40 or 80 MHz for the wideband paths. Changing the span causes the resolution bandwidth to change automatically, and will affect data acquisition time. The **Span** key is also accessible under the **Meas Setup** menu.
- **IF Path** - This key is only available if you have both the Option B7J and either Option 122 or 140. Selects either the standard narrowband IF hardware path or the wideband hardware path.

---

### NOTE

The **I/Q Waveform** window must be active in the **Spectrum** view to access the following **Span X Scale** key menu:

- **Scale/Div** - Sets the horizontal scale by changing a time value per division. The range is 1.00 ns to 1.00 s per division. The default setting is 1883  $\mu$ s per division in narrowband path, 235 ns per division in wideband path. However, since the **Scale Coupling** default is **On**, this value is automatically determined by the measurement results. When you set a value manually, **Scale Coupling** automatically changes to **Off**.
- **Ref Value** - Sets the reference value ranging from -1.00 to 10.0 s. The default setting is 0.00 s. However, since the **Scale Coupling** default is **On**, this value is automatically determined by the measurement results. When you set a value manually, **Scale Coupling** automatically changes to **Off**.
- **Ref Position** - Sets the reference position to either **Left**, **Ctr** (center) or **Right**. The default setting is **Left**.

- **Scale Coupling** - Toggles the scale coupling function between **On** and **Off**. The default setting is **On**. Upon pressing the **Restart** front-panel key or **Restart** softkey under the **Meas Control** menu, this function automatically determines the scale per division and reference values based on the measurement results. When you set a value to either **Scale/Div** or **Ref Value** manually, **Scale Coupling** automatically changes to **Off**.

## AMPLITUDE Y Scale Key Menu

---

### NOTE

The Spectrum window must be active in the **Spectrum** view to access the following **AMPLITUDE Y Scale** key menu:

---

- **Scale/Div** - Sets the vertical scale by changing an amplitude value per division. The range is 0.10 dB to 20.00 dB per division or 1.00 nV to 20.00 V per division, respectively. The default setting is 10.00 dB or 100.0 mV. However, since the **Scale Coupling** default is **On**, this value is automatically determined by the measurement results. When you set a value manually, **Scale Coupling** automatically changes to **Off**.
- **Ref Value** - Sets the reference value ranging from – 250.00 to 250.00 dBm or – 250.00 to 250.00 V. The default setting is 0.00 dBm or 0.00 V. However, since the **Scale Coupling** default is **On**, this value is automatically determined by the measurement results. When you set a value manually, **Scale Coupling** automatically changes to **Off**.
- **Ref Position** - Sets the reference position to either **Top**, **Ctr** (center), or **Bot** (bottom). The default setting is **Ctr**.
- **Scale Coupling** - Toggles the scale coupling function between **On** and **Off**. The default setting is **On**. Upon pressing the **Restart** front-panel key or **Restart** softkey under the **Meas Control** menu, this function automatically determines the scale per division and reference values based on the measurement results. When you set a value to either **Scale/Div** or **Ref Value** manually, **Scale Coupling** automatically changes to **Off**.

## Display Key Menu

The Display Key is not active for this measurement.

## Marker Key Menu

- **Select 1 2 3 4** - Activates up to four markers with the corresponding numbers, respectively. The selected number is underlined and its function is defined by pressing the **Function** key. The default is 1.

- **Normal** - Activates the selected marker to read the frequency and amplitude of the marker position on the spectrum trace. Marker position is controlled by the **RPG** knob.
- **Delta** - Reads the differences in frequency and amplitude between the selected marker and the next marker.
- **Function** - Selects the marker function to be **Band Power**, **Noise**, or **Off**. The default is **Off**. If set to **Band Power**, you need to select **Delta**.
- **Trace** - Places the selected marker on the **Spectrum** trace.
- **Off** - Turns off the selected marker.
- **Shape Diamond** - Accesses the menu to define the selected marker shape to be **Diamond**, **Line**, **Square**, or **Cross**. The default shape is **Diamond**.
- **Marker All Off** - Turns off all of the markers.

### Peak Search Key

The front-panel Search key performs a peak search when pressed. A marker will automatically be activated at the highest peak.

---

## Waveform (Time Domain) Keys

---

**NOTE** You must have selected **Waveform** under the **MEASURE** menu to access these menus.

---

### Measurement Setup Key Menu

Key Path: **Meas Setup**

- **Sweep Time** - Specifies the measurement acquisition time which is used as the length of the time capture record. The range is 1.0  $\mu$ s to 100.0 s, depending upon the resolution bandwidth setting and the available internal memory size for acquisition points.
- **Meas Time** - Specifies the measurement acquisition time which is used as the length of the time capture record. The range is 10 ns to 100.0 s, depending upon the resolution bandwidth setting and the available internal memory size for acquisition points.
- **Res BW** - Sets the measurement bandwidth. The range is 10 Hz to 8 MHz using the Gaussian filter selected from **RBW Filter** under the Advanced menu, or 10 Hz to 10 MHz using the Flat top filter selected from **RBW Filter**. A larger bandwidth results in a larger number of acquisition points and reduces the maximum value allowed for the sweep time.
- **IF BW** - For PSA Option 122 or 140 only. Sets the measurement bandwidth. In wideband operation the range is 10 kHz to 80 MHz.(Option 122) or 10 kHz to 40 MHz (Option 140). The narrowband range is 10 Hz to 10 MHz. A larger bandwidth results in a larger number of acquisition points and reduces the maximum value allowed for the measurement time.
- **Wideband Setup** configures the wideband hardware path. This functionality is only available with the wideband options 122 or 140.
  - **Wideband IF Gain** - Sets the gain for the wideband IF path. You must have selected **IF Path Wide**. Increasing the gain can increase the amplitude of small signals as long as you do not overdrive the hardware.
  - **Wideband Filtering** - Accesses the menu to configure several aspects of the wideband filter.
    - Filter Type** - Selects **None** for no filtering, or **Raised Cosine**, **RRC** (root-raised cosine), **Nyquist**, **Root Nyquist**, **Gaussian** and **Flat Top**.
    - Filter Alpha** - Selects the filter alpha.

- ❑ **Filter BW** - Selects the filter bandwidth. Bandwidth is not entered as a frequency. The value is entered as a ratio of the current instrument sampling rate (that is, BW/sample rate).
- **Sample Rate** - Allows arbitrary sample rates with 5 digits of resolution from 12.5 kHz to 100 MHz. The sample rate is coupled with the selected filter shape and bandwidth, and with the maximum available captured data.
- **Block Size** - This key is for information only. Block size is coupled with the IF bandwidth and the measurement time.
- **Wideband Advanced** - Accesses the advanced settings for the Option 122 or 140 wideband IF hardware path.

---

**NOTE**

Parameters under the **Wideband Advanced** key seldom need to be changed. Any changes from the default advanced values may result in invalid measurement data.

---

- ❑ **ADC Corr** performs an ADC calibration to reduce the spectral image and applies the corrections.
  - ❑ **IF Flat Corr** turns IF flatness corrections on and off for the Option 122 or 140 wideband IF. This control is independent of the narrowband IF flatness control.
  - ❑ **WB ADC Dither** toggles the ADC dither function on or off. The “ADC dither” refers to the introduction of noise to the digitized steps of the analog-to-digital converter; the result is an improvement in amplitude accuracy. The wideband dither control does not affect the ADC dither in the narrowband IF path.
  - ❑ **Trig Interp** is an advanced function that usually does not need to be changed. During normal operation trigger interpolation is on and the trigger offset is 0 seconds. At low sample rates the trigger interpolation can cause hardware unlock errors, so you may want to turn it off. You must have an external trigger source to use this functionality.
- **Average**
    - **Avg Number** - Changes the number of N averages.
    - **Avg Mode** - Toggles the Averaging Mode between **Exp** (exponential) and **Repeat**. This selection only affects the averaging result after the number of N averages is reached. The N is set using the **Avg Number** key.

- ❑ **Normal** - Normal (linear) averaging is always used until the specified number of N averages is reached. When the **Measure** key under **Meas Control** is set to **Single**, data acquisition is stopped when the number of N averages is reached, thus **Avg Mode** has no effect in the single measurement mode.
  - ❑ **Exp** - Exponential averaging: When **Measure** is set to **Cont**, data acquisition will continue indefinitely. Exponential averaging is used with a weighting factor of N (the displayed count of averages stops at N). Exponential averaging weights new data more heavily than old data, which allows tracking of slow-changing signals. The weighting factor N is set using the **Avg Number** key.
  - ❑ **Repeat** - Repeat averaging: When **Measure** is set to **Cont**, data acquisition will continue indefinitely. After the number of N averages is reached, all previous result data is cleared and the average count displayed is set back to 1. This is equivalent to being in **Measure Single** and pressing the **Restart** key each time the single measurement finishes.
- **Avg Type** - Accesses the menu of the following average types only for making Spectrum (Frequency Domain) and Waveform (Time Domain) measurements:
- ❑ **Pwr Avg (RMS)** - Executes the true power averaging which is calculated by averaging the rms voltage. This is the most accurate type.
  - ❑ **Log-Pwr Avg (Video)** - Simulates the traditional spectrum analyzer type of averaging by calculating the log of the power. This type of averaging will underestimate the power when the signal is noise-like.
  - ❑ **Voltage Avg** - Executes voltage averaging.
  - ❑ **Maximum** - Captures peak voltage data. Simulates the traditional spectrum analyzer peak hold function.
  - ❑ **Minimum** - Captures the minimum voltage data, similar to the maximum function.
- **Time Avg Num** - Changes the number of time averages to be made when using the Option 122 or 140 wideband hardware. This averaging requires a frame trigger and is much faster than the standard averaging. This hardware averaging is done on the complex voltage time trace data before any measurement application averaging is done. Both types of averaging can be done on the same measurement data.



When time averaging is being done, each trace update represents N fresh data acquisitions averaged together, when N is the number of averages. You cannot access the individual time records that are being averaged in the hardware averager.

---

**CAUTION** If triggering is set incorrectly, averaged signal results can approach zero. “HW Average” is displayed when averaging is **On**.

---

**TIP** If your measurement results vary or provide unexpected values, try turning Averaging **Off** and execute single, non-averaged measurements to check your triggering setup. Press **Meas Control, Measure, Single** to make non-continuous measurements.

- **Trig Source**

Key path: **Meas Setup, Trig Source**

---

**NOTE** Changing the selection in the **Trig Source** menu alters the trigger source for the selected measurement only.

- **Free Run (Immediate)** - A trigger occurs at the time the data is requested, completely asynchronous with the RF or IF signal.
- **Video (Envlp)** - An internal IF envelope trigger that occurs at the absolute threshold level of the IF signal level.
- **RF Burst (IF Wideband)** - An internal wideband RF burst trigger that has the automatic level control for burst signals. It triggers at the level that is set relative to the peak RF signal (12 MHz bandwidth) input level. (Not available for Option 122 or 140 when using the wideband IF path.)
- **Ext Front** - Activates the front panel external trigger input (**EXT TRIGGER INPUT**) port. The external signal must be between – 5.00 and +5.00 V with 1 or 10 mV resolution.
- **Ext Rear** - Activates the rear-panel external trigger input (**TRIGGER IN**) port. The external signal must be between – 5.00 and +5.00 V with 1 or 10 mV resolution.
- **Frame** - Uses the internal frame clock to generate a trigger signal. The clock parameters are controlled under the **Mode Setup** key or the measurement firmware, but not both. Refer to the specific measurement section for details.
- **Line** - Sets the trigger to the internal line mode. Sweep triggers occur at intervals synchronous to the line frequency. See the specific measurement section for details.

- **IF Path** Only for PSA with Option 122 or 140 installed. Selects either the standard narrowband IF hardware path or the wideband hardware path.
- **Restore Meas Defaults** - Presets only the settings that are specific to the selected measurement by pressing **Meas Setup, More, Restore Meas Defaults**. This will set the measure setup parameters, for the currently selected measurement only, to the factory defaults.
- **(Narrowband) Advanced** Accesses the menu to change the following parameters:

**CAUTION**

The advanced features should be used only if you are familiar with their operation. Changes from the default values may result in invalid data.

The **Narrowband** key label word is only present if you have Option B7J and either Option 122 or 140. Parameters that are under the **(Narrowband) Advanced** key only affect the standard narrow band IF path. The wideband IF advanced functions are found under the **Wideband Advanced** key.

- **Pre-ADC BPF** - Toggles the Pre-ADC Bandpass Filter function between **On** or **Off**. The default setting is **Off**. The Pre-ADC Bandpass Filter is useful for rejecting nearby signals, so that sensitivity within the span range can be improved by increasing the ADC range gain.
- **RBW Filter** - Toggles the Resolution Bandwidth Filter selection between **Flat** and **Gaussian**. If set to **Gaussian**, the filter provides more even time-domain response, particularly for “bursts”. If set to **Flat**, the filter provides a flatter bandwidth but is less accurate for “pulse responses”. A flat top filter also requires less memory and allows longer data acquisition times. For most Waveform applications, the Gaussian filter is recommended. The resolution bandwidth range is 10 Hz to 8 MHz using the Gaussian filter or 10 Hz to 10 MHz using the flat top filter.
- **ADC Range** - Accesses the menu to select one of the ADC Ranging functions:
  - Auto** - Automatically adjusts the signal range for optimal measurement results.
  - AutoPeak** - Continuously searches for the highest peak signal.
  - AutoPeakLock** - Adjusts the range for the highest peak signal it identifies. It retains the range settings determined by that peak signal, even when the peak signal is no longer present.

- Manual** - Accesses the selection menu of values, None to +18 dB, to set the ADC range level. Also note that manual ranging is best for CW signals.
- **Data Packing** - Selects **Auto** (the default) or the **Short (16 bit)**, **Medium (24 bit)**, and **Long (32 bit)** methods of data packing. The short, medium, and long methods are not compatible with all settings and should not be used unless you are familiar with data packing methods. **Auto** is the preferred choice.
  - Auto** - The data packing value most appropriate for current instrument settings is selected automatically.
  - Short (16 bit)** - Select this to pack data every 16 bits.
  - Medium (24 bit)** - Select this to pack data every 24 bits.
  - Long (32 bit)** - Select this to pack data every 32 bits.
- **ADC Dither** - Toggles the **ADC Dither** function between **On** and **Off**. The default setting is **Off**. If set to **On**, the **ADC Dither** refers to the introduction of noise to the digitized steps of the analog-to-digital converter, and results in better amplitude linearity and resolution in low level signals. However, it also results in reduced dynamic range by approximately 3 dB.
- **Decimation** - Allows you to toggle the **Decimation** function between **On** and **Off**, and to set the decimation value. Decimation allows longer acquisition times for a given bandwidth by eliminating data points. Long time captures can be limited by the instrument data acquisition memory. Decimation numbers 1 to 4 describe the factor by which the number of points are reduced. The default setting is 1, which results in no data point reduction.

Table 3-2

Waveform (Time Domain) Measurement Defaults

Measurement Parameter	Factory Default Condition
Sweep Time	2.000 ms
Res BW	100.000 kHz
Averaging: Avg Number Avg Mode Avg Type	10; Off Exp Pwr Avg (RMS)
Trig Source	Free Run (Immediate)
IF Path (requires Option B7J and Option 122 or 140)	Narrow
Wideband IF Gain (Option 122 or 140)	0.00 dB

Table 3-2

**Waveform (Time Domain) Measurement Defaults**

Measurement Parameter	Factory Default Condition
Wideband Filtering (Option 122 or 140) Filter Type Filter Alpha Filter BW	None 0.30 0.50
<b>RF Envelope View</b> SPAN X Scale - Scale/Div AMPLITUDE Y Scale - Scale/Div	200.0 $\mu$ s 10.00 dB
<b>I/Q Waveform View:</b> SPAN X Scale -Scale/Div AMPLITUDE Y Scale - Scale/Div	200.0 $\mu$ s 100.0 mV
<b>(Narrowband) Advanced</b>	
Pre-ADC BPF	Off
RBW Filter	Gaussian
ADC Range	Auto
Data Packing	Auto
ADC Dither	Off
Decimation	Off
<b>Wideband Advanced (Option 122 or 140)</b>	
ADC Correction	On
IF Flatness Corrections	On
WB ADC Dither	On
Trigger Interpolation	On

**Trace/View Key Menu**Key Path: **Trace/View**

- **RF Envelope** - Displays a time domain graph of the signal. The measured values for the mean power and peak-to-mean power are shown in the text window.

**Figure 3-3** Waveform Measurement - RF Envelope (Default View)

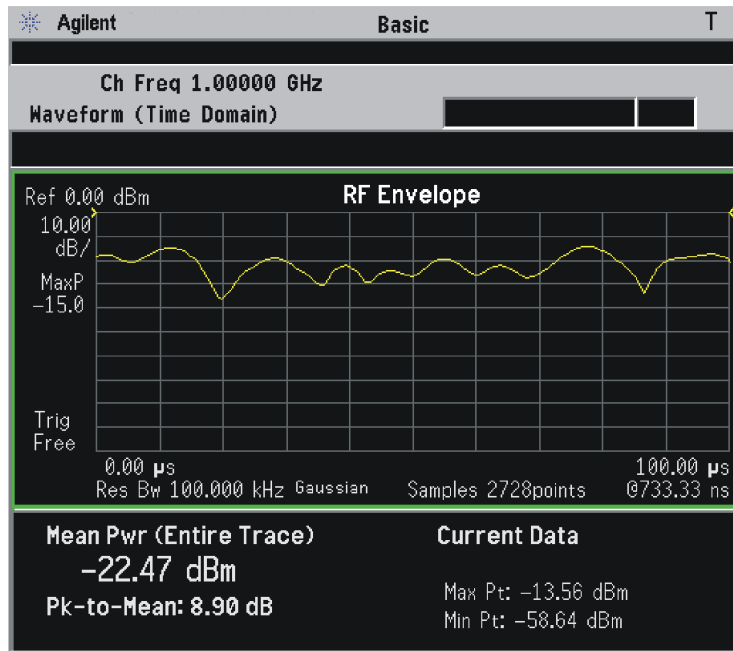

\*Meas Setup: Trace/View = RF Envelope,  
Others = Factory default settings

\*Input signal: cdma2000 Rev 8, SR1, 9 Channel

- **I/Q Waveform** - Provides a view of the I and Q waveforms together on the same graph in parameters of voltage versus time in linear scale. Changes to measurement time or IF bandwidth can affect data acquisition.

Figure 3-4

### Waveform Measurement - I/Q Waveform View

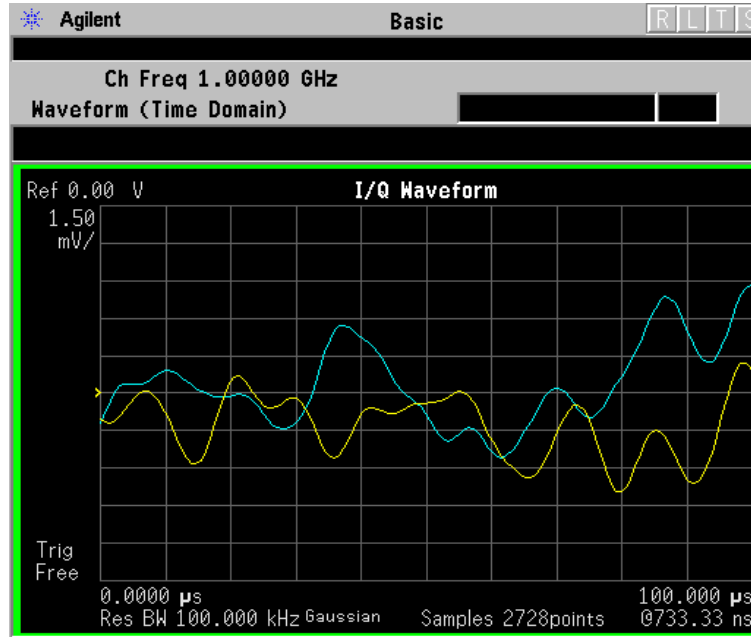

- Trace Display - Press this key to access the trace selection menu. The currently selected trace type is shown on the Trace Display key.
  - **All** - Views both the current trace and the average trace.
  - **Average** - Views only the average trace (in blue color). See the **Meas Setup, Average** keys to select different types of averaging.
  - **Current** - Views only the trace (in yellow color) for the latest data acquisition.

### SPAN X Scale Key Menu

Key Path: **SPAN X Scale**

#### NOTE

The **SPAN X Scale** key accesses the menu to modify the horizontal parameters common to the scaled windows for this measurement. Use the **Meas Time** key under the **Meas Setup** menu to control the horizontal time span for this measurement:

- **Scale/Div** - Sets the horizontal scale by changing a time value per division. The range is 1.0 ns to 1.000 s per division with 0.01 ns resolution. The default setting is 200.0  $\mu$ s per division. However, since the **Scale Coupling** default is **On**, this value is automatically determined by the measurement result. When you set a value manually, **Scale Coupling** automatically changes to **Off**.

- **Ref Value** - Sets the reference value ranging from – 1.0 to 10.0 s. The default setting is 0.00 s. However, since the **Scale Coupling** default is **On**, this value is automatically determined by the measurement result. When you set a value manually, **Scale Coupling** automatically changes to **Off**.
- **Ref Position** - Sets the **Ref Position** to either **Left**, **Ctr** (center) or **Right**. The default setting is **Left**.
- **Scale Coupling** - Toggles the **Scale Coupling** function between **On** and **Off**. The default setting is **On**. Upon pressing the **Restart** front-panel key or **Restart** softkey under the **Meas Control** menu, this function automatically determines the scale per division and reference values based on the measurement results. When you set a value to either **Scale/Div** or **Ref Value** manually, **Scale Coupling** automatically changes to **Off**.

## AMPLITUDE Y Scale Key Menu

Key Path: **AMPLITUDE Y Scale**

- **Scale/Div** - Sets the vertical scale by changing an amplitude value per division. The range is 0.10 to 20.00 dB per division with 0.01 dB resolution. The default setting is 10.00 dB per division. However, since the **Scale Coupling** default is **On**, this value is automatically determined by the measurement result. When you set a value manually, **Scale Coupling** automatically changes to **Off**.
- **Ref Value** - Sets the **Ref Value**, ranging from – 250.00 to 250.00 dBm. The default setting is 0.00 dBm. However, since the **Scale Coupling** default is **On**, this value is automatically determined by the measurement result. When you set a value manually, **Scale Coupling** automatically changes to **Off**.
- **Ref Position** - Sets the **Ref Position** to either **Top**, **Ctr** (center), or **Bot** (bottom). The default setting is **Top**.
- **Scale Coupling** - Toggles the **Scale Coupling** function between **On** and **Off**. The default setting is **On**. Upon pressing the **Restart** front-panel key or **Restart** softkey under the **Meas Control** menu, this function automatically determines the scale per division and reference values based on the measurement results. When you set a value to either **Scale/Div** or **Ref Value** manually, **Scale Coupling** automatically changes to **Off**.

## Display Key Menu

The **Display** key is not available for this measurement.

## Marker Key Menu

Key Path: **Marker**

The **Marker** front-panel key accesses the menu to configure the markers.

- **Select 1 2 3 4** - Activates up to four markers with the corresponding numbers, respectively. The selected number is underlined and its function is defined by pressing the **Function** key. The default is 1.
- **Normal** - Activates the selected marker to read the time position and amplitude of the marker on the RF envelope or Signal Envelope trace. The marker position is controlled by the **RPG** knob.
- **Delta** - Reads the differences in frequency and either time position or amplitude, between the selected marker and the next marker.
- **Function** - Selects the marker function to be **Band Power**, **Noise**, or **Off**. The default is **Off**. If set to **Band Power**, you need to select **Delta**.
- **Trace** - Places the selected marker on **RF Envelope**.
- **Off** - Turns off the selected marker.
- **Shape Diamond** - Accesses the menu to define the selected marker shape to be **Diamond**, **Line**, **Square**, or **Cross**. The default shape is **Diamond**.
- **Marker All Off** - Turns off all of the markers.

## Peak Search Key

Key Path: **Search**

The front panel **Search** key performs a peak search when pressed. A marker will automatically be activated at the highest peak.

---

### NOTE

In the Waveform measurement, the Mean Pwr (Entire Trace) value plus the Pk-to-Mean value will sum to equal the current Max Pt. value as shown in the data window below the RF Envelope or Signal Envelope display. If you do a MARKER Peak Search (Search) with averaging turned Off, the marker will find the same maximum point. However, if you turn averaging on, the Pk-to-Mean value will use the highest peak found for any acquisition during averaging, while the marker peak will look for the peak of the display, which is the result of n-averages. This will usually result in differing values for the maximum point.

---



## Power Stat CCDF Keys

### NOTE

You must have selected **Power Stat CCDF** under the **MEASURE** menu to access these menus. This key is only present if your instrument is an E4440A, E4443A, or E4445A with Option 122 or 140 installed.

## Meas Setup Key Menu

Key Path: **Meas Setup**

- **Meas BW** - Allows you to set the measurement bandwidth according to the channel bandwidth.
- **Meas Interval** - Sets the number of data points that will be used as the measurement interval.
- **Counts** - Allows you to set the accumulated number of sampling points for data acquisition. The range is 1.000 kpt (kilo points) to 2.00000 Gpt (Giga points) with 1 kpt resolution. While this key is activated, enter a value from the numeric keypad and terminate with one of the unit keys shown.
- **Wideband Setup** - Allows you to configure the wideband hardware path.
  - **Wideband IF Gain** - Sets the gain for the wideband IF path in 2 dB steps from -12 to +12 dB. Increasing the gain can increase the amplitude of small signals as long as you don't overdrive the hardware. Wideband gain should usually be adjusted after setting the input attenuation.
  - **Wideband Filtering** - Accesses the keys to configure the optional channel filter. The default is no filtering.
    - Filter Type** - Selects **None** for no filtering, or **Raised Cosine**, **RRC** (root-raised cosine), **Nyquist**, **Root Nyquist**, or **Gaussian**.
    - Filter Alpha** - Specifies the channel filter alpha for cosine and Nyquist filters applied within the wideband digital IF. This filter alpha is the ratio of transition bandwidth divided by 2, to filter bandwidth. Pressing Filter Alpha allows you to enter this numeric value.
    - Filter BW** - Specifies the bandwidth of the filter with respect to the sample rate (i.e. BW/sample rate) of channel filter.
  - **Sample Rate** - Sets the sampling rate. This parameter is coupled with the **Meas BW**. Changes to either **Sample Rate** or **Meas BW** will affect both parameters.

Key Reference  
Power Stat CCDF Keys

- **Block Size** - Shows the number of samples within one Meas Interval. This key is for information only. It is always grayed out.
- **Wideband Advanced** - Accesses the advanced settings for the wideband IF hardware path.

---

**NOTE**

Parameters under the **Wideband Advanced** key seldom need to be changed. Any changes from the default advanced values may result in invalid measurement data.

---

- ADC Corr** - Turning corrections on performs an ADC calibration to reduce the spectral image and applies the corrections.
- IF Flat Corr** - Turns IF flatness corrections on and off in all wideband IF measurements.
- WB ADC Dither** Toggles the wideband dither signal on or off. The “ADC dither” refers to the introduction of noise to the digitized steps of the analog-to-digital converter; the result is an improvement in amplitude accuracy. Use of the ADC dither, however, reduces the dynamic range by approximately 3 dB. It should only be turned off when measuring a noise-like signal and the 1 to 2 dB extra dynamic range is needed. The wideband dither control does not affect the ADC dither in the narrowband IF path.
- Trig Interp** - This key toggles the Trigger interpolation function on or off.
- **Wideband Setup** - Allows you to configure the wideband hardware path.
  - **Wideband IF Gain** - Sets the gain for the wideband IF path in 2 dB steps from -12 to +12 dB. Increasing the gain can increase the amplitude of small signals as long as you don’t overdrive the hardware. Wideband gain should usually be adjusted after setting the input attenuation.
  - **Wideband Filtering** - Accesses the keys to configure the optional channel filter. The default is no filtering.
    - Filter Type** - Selects **None** for no filtering, or **Raised Cosine**, **RRC** (root-raised cosine), **Nyquist**, **Root Nyquist**, or **Gaussian**.
    - Filter Alpha** - Specifies the channel filter alpha for cosine and Nyquist filters applied within the wideband digital IF. This filter alpha is the ratio of transition bandwidth divided by 2, to filter bandwidth. Pressing Filter Alpha allows you to enter this numeric value.

- ❑ **Filter BW** - Specifies the bandwidth of the filter with respect to the sample rate (i.e. BW/sample rate) of channel filter.
- **Sample Rate** - Sets the sampling rate. This parameter is coupled with the **Meas BW**. Changes to either **Sample Rate** or **Meas BW** will affect both parameters.
- **Block Size** - Shows the number of samples within one Meas Interval. This key is for information only. It is always grayed out.
- **Wideband Advanced** - Accesses the advanced settings for the wideband IF hardware path.

---

**NOTE**

Parameters under the **Wideband Advanced** key seldom need to be changed. Any changes from the default advanced values may result in invalid measurement data.

---

- ❑ **ADC Corr** - Turning corrections on performs an ADC calibration to reduce the spectral image and applies the corrections.
- ❑ **IF Flat Corr** - Turns IF flatness corrections on and off in all wideband IF measurements.
- ❑ **WB ADC Dither** Toggles the wideband dither signal on or off. The “ADC dither” refers to the introduction of noise to the digitized steps of the analog-to-digital converter; the result is an improvement in amplitude accuracy. Use of the ADC dither, however, reduces the dynamic range by approximately 3 dB. It should only be turned off when measuring a noise-like signal and the 1 to 2 dB extra dynamic range is needed. The wideband dither control does not affect the ADC dither in the narrowband IF path.
- ❑ **Trig Interp** - This key toggles the Trigger interpolation function on or off.

- **Trig Source**

Key path: **Meas Setup, Trig Source**

---

**NOTE**

Changing the selection in the **Trig Source** menu alters the trigger source for the selected measurement only.

---

- **Free Run (Immediate)** - A trigger occurs at the time the data is requested, completely asynchronous with the RF or IF.
- **Video (Envlp)** - An internal IF envelope trigger that occurs at the absolute threshold level of the signal passed by the IF signal level.

- **Ext Front** - Activates the front panel external trigger input (**EXT TRIGGER INPUT**) port. The external signal must be between  $-5.00$  and  $+5.00$  V with 1 or 10 mV resolution.
- **Ext Rear** - Activates the rear-panel external trigger input (**TRIGGER IN**) port. The external signal must be between  $-5.00$  and  $+5.00$  V with 1 or 10 mV resolution.
- **Frame** - Uses the internal periodic timer to generate a trigger signal.
- **Line** - Sets the trigger to the internal line mode. Sweep triggers occur at intervals synchronous to the line frequency.
- **Restore Meas Defaults** - Presets only the settings that are specific to the selected measurement by pressing **Meas Setup, More (1 of 2), Restore Meas Defaults**. This will set the measure setup parameters, for the currently selected measurement only, to the factory defaults.

---

## 4 Programming Commands

These commands are only available when Basic mode (Option B7J, 122 or 140) has been selected. Use **INSTRUMENT:SElect BASIC.** to select the mode. When these modes are selected, commands that are unique to another mode are not available.

- “CALCulate Subsystem” on page 132
- “CALibration Subsystem” on page 154
- “CONFigure Subsystem” on page 155
- “DISPlay Subsystem” on page 156
- “FETCh Subsystem” on page 165
- “FORMat Subsystem” on page 167
- “INITiate Subsystem” on page 169
- “INSTrument Subsystem” on page 172
- “MEASure Group of Commands” on page 175
- “SENSe Subsystem” on page 187
- “TRIGger Subsystem” on page 232

## Programming Command Compatibility Across Model Numbers and Across Modes

### Across PSA Modes: Command Subsystem Similarities

When you select different modes you get different sets of available programming commands. That is, *only* the commands that are appropriate for the current mode are available. Also, some commands have the same syntax in different modes but have different ranges or settings that are only appropriate to the current mode.

The following table shows which command subsystems are the same across different modes. If there is no “X” by a particular subsystem, then the set of available commands is different in those modes. Command ranges or defaults may also be different. Refer to the programming command descriptions in the documentation for each mode for details.

Command Subsystem	Same command set is available:  SA mode compared with the application modes: W-CDMA, cdmaOne, cdma2000, 1xEV-DO, Basic, GSM, EDGE, NADC, or PDC	Same command set is available:  SA mode compared with the application mode: Phase Noise
IEEE common commands	X	X
ABORt	X	X
CALCulate		
CALibration	X	X
CONFigure		
COUPle	not available in these application modes	not available in this application mode
DISPlay		
FETCh		
FORMat		X
HCOpy	X	X
INITiate		
INPut	not available in these application modes	X

Command Subsystem	Same command set is available:  SA mode compared with the application modes: W-CDMA, cdmaOne, cdma2000, 1xEV-DO, Basic, GSM, EDGE, NADC, or PDC	Same command set is available:  SA mode compared with the application mode: Phase Noise
MEASure		
MEMory	X	X
MMEMory	X	X
MMEMory:STORe:TRACe	not available in application modes	X
READ		
[SENSe] [SENSe:]CHANnel [SENSe:]CORRection [SENSe:]FEED [SENSe:]FREQuency:CE NTer [SENSe:]FREQuency: <other subsystems> [SENSe:]<measurement> [SENSe:]POWer [SENSe:]RADio [SENSe:]SYNC	X  not available in application modes	  not available in application modes
STATus	X	X
SYSTem	X	X
TRACe	not available in application modes	X
TRIGger		
UNIT	X	X



## Across PSA Modes: Specific Command Differences

Some programming commands operate differently depending on which Mode the analyzer is set to.

Command	Spectrum Analysis, Phase Noise and Noise Figure Mode	Basic, cdmaOne, cdma2000, 1xEV-DO, W-CDMA, GSM, EDGE, NADC, PDC Modes
CONFigure: <measurement>	Accesses the measurement and sets the instrument settings to the defaults. Averaging is turned on and set to 10. The instrument is put in single measurement mode. It does not initiate a measurement. Use INIT:IMM to make one measurement.	Accesses the measurement and sets the instrument settings to the defaults. If you were already in single measurement mode, it takes one measurement and then waits. If you were in continuous measurement mode it continues to measure.
*ESE default	Default is 255 which means that every error/status bit change that has occurred will be returned with a *ESR? query. You must set the value of *ESE to choose only the bits/status that you want returned.	Default is 0 which means that none of the error/status bit changes that have occurred will be returned with a *ESR? query. You must set the value of *ESE to choose the bits/status that you want returned.
TRIGger commands	For these modes, only one trigger source can be selected and it will be common across the modes. Also, only one value can be set for the trigger delay, level, or polarity.	For these modes, a unique trigger source can be selected for each mode. Also, each trigger source can have unique settings for the its delay, level, and polarity.
Saving and recalling traces	Traces can only be saved when in the Spectrum Analysis mode (MMEM:STOR:TRAC). This is because the instrument state must be saved along with the trace data and the state data varies depending on the number of modes currently available in the instrument.	

## Using Applications in PSA Series vs. VSA E4406A

## NOTE

This information *only* applies to the application modes: Basic, cdmaOne, cdma2000, 1xEV-DO, W-CDMA, GSM, EDGE, NADC, and PDC.

Command	PSA Series	VSA E4406A: A.04.00	VSA E4406A: A.05.00
*RST	Resets instrument, putting it in continuous measurement mode. Use INIT:CONT OFF to select single measurement mode and INIT:IMM to start one measurement.	Resets instrument, putting it in single measurement mode. One measurement is initiated when the command is sent.	Resets instrument, putting it in single measurement mode. No measurement is initiated when the command is sent. Use INIT:IMM to start one measurement.
CONFigure: <measurement>	Accesses the measurement and sets the instrument settings to the defaults. If you were already in single measurement mode, it takes one measurement and then waits.	Same as PSA. Accesses the measurement and sets the instrument settings to the defaults. If you were already in single measurement mode, it takes one measurement and then waits.	Accesses the measurement and sets the instrument settings to the defaults. If you were already in single measurement mode, it does not initiate a measurement. Use INIT:IMM to make one measurement.
*ESE default	Default is 255 which means that every error/status bit change that has occurred will be returned with a *ESR? query. You must set the value of *ESE to choose only the bits/status that you want returned.	Default is 0 which means that none of the error/status bit changes that have occurred will be returned with a *ESR? query. You must set the value of *ESE to choose the bits/status that you want returned.	Same as VSA A.04.00. Default is 0 which means that none of the error/status bit changes that have occurred will be returned with a *ESR? query. You must set the value of *ESE to choose the bits/status that you want returned.
*LRN	The command is <i>not</i> available.	The command is available.	The command is available.

Command	PSA Series	VSA E4406A: A.04.00	VSA E4406A: A.05.00
TRIGger commands	<p>In Spectrum Analysis mode only one value can be set for the trigger's source, delay, level, or polarity.</p> <p>Basic, GSM, EDGE, cdmaOne, cdma2000, W-CDMA, NADC, PDC modes function the same as VSA</p>	<p>You can select a unique trigger source for each mode. Each trigger source can have unique settings for the its delay, level, and polarity.</p>	<p>Same as VSA A.04.00.</p> <p>You can select a unique trigger source for each mode. Each trigger source can have unique settings for the its delay, level, and polarity.</p>
AUTO ON OFF control and setting manual values	<p>We recommend that you set a function's automatic state to OFF, before you send it your manual value.</p> <p>Some functions will turn off the automatic mode when you send a specific manual value, but others will not. This also varies with the instrument model.</p>	<p>We recommend that you set a function's automatic state to OFF, before you send it your manual value.</p> <p>Some functions will turn off the automatic mode when you send a specific manual value, but others will not. This also varies with the instrument model.</p>	<p>We recommend that you set a function's automatic state to OFF, before you send it your manual value.</p> <p>Some functions will turn off the automatic mode when you send a specific manual value, but others will not. This also varies with the instrument model.</p>

---

## Using the Status Registers

The Section “[E4406A Core Status Register System](#)” on page 125 shows the E4406A instrument status registers and their hierarchy.

The Section “[PSA Core Status Register System \(Page 1 of 2\)](#)” on page 123 shows the PSA instrument status registers and their hierarchy. Note that some measurement personality Modes use the E4406A status register design instead of the PSA design. (These include Basic Mode, NADC/PDC, GSM/EDGE, cdmaOne, cdma2000/1xEV-DV, W-CDMA/HSDPA and 1xEV-DO.)

- “[What Status Registers Are](#)” on page 116
- “[How to Use the Status Registers](#)” on page 119
- “[Using a Status Register](#)” on page 120
- “[Using the Service Request \(SRQ\) Method](#)” on page 121
- “[E4406A Core Status Register System](#)” on page 125
- “[PSA Core Status Register System \(Page 1 of 2\)](#)” on page 123
- “[Standard Event Status Register](#)” on page 129
- “[Operation and Questionable Status Registers](#)” on page 131

### What Status Registers Are

The status system is comprised of multiple registers that are arranged in a hierarchical order. The lower-level status registers propagate their data to the higher-level registers in the data structures by means of summary bits. The status byte register is at the top of the hierarchy and contains general status information for the instrument’s events and conditions. All other individual registers are used to determine the specific events or conditions.

The operation and questionable status registers are sets of registers that monitor the overall instrument condition. They are accessed with the `STATUS:OPERation` and `STATUS:QUEStionable` commands in the `STATUS` command subsystem. Each register set is made up of five registers:

**Condition Register** it reports the real-time state of the signals monitored by this register set. There is no latching or buffering for a condition register.

**Positive Transition Register** this filter register controls which signals will set a bit in the event register when the signal makes a low to high transition (when the condition bit changes from 0 to 1).

**Negative Transition Register** this filter register controls which signals will set a bit in the event register when the signal makes a high to low transition (when the condition bit changes from 1 to 0).

**Event Register** it latches any signal state changes, in the way specified by the filter registers. Bits in the event register are never cleared by signal state changes. Event registers are cleared when read. They are also cleared by \*CLS and by presetting the instrument.

**Event Enable Register** it controls which of the bits, being set in the event register, will be summarized as a single output for the register set. Summary bits are then used by the next higher register.

The STATUS:QUESTIONable registers report abnormal operating conditions. The status register hierarchy is:

1. The summary outputs from the six STATUS:QUESTIONable:<keyword> detail registers are inputs to the STATUS:QUESTIONable register.
2. The summary output from the STATUS:QUESTIONable register is an input to the Status Byte Register. See the Section [“E4406A Core Status Register System” on page 125](#) [“PSA Core Status Register System \(Page 1 of 2\)” on page 123](#).

The STATUS:OPERation register set has no summarized inputs. The inputs to the STATUS:OPERation:CONDition register indicate the real time state of the instrument. The STATUS:OPERation:EVENT register summary output is an input to the Status Byte Register.

The STATUS:OPERation:ENABLE register has an additional function in the E4406A. It is ANDed with the STATUS:OPERation:CONDition register to determine what the instrument busy state is, that is then interpreted by the \*OPC, \*OPC? and \*WAI commands. If the ANDed result is non-zero the instrument is considered busy.

### What Status Register SCPI Commands Are

Most monitoring of the instrument conditions is done at the highest level using the IEEE common commands indicated below. Complete command descriptions are available in the IEEE commands section at the beginning of the language reference. Individual status registers can be set and queried using the commands in the STATUS subsystem of the language reference.

\*CLS (clear status) clears the status byte by emptying the error queue and clearing all the event registers.

\*ESE, \*ESE? (event status enable) sets and queries the bits in the enable register part of the standard event status register.

\*ESR? (event status register) queries and clears the event register part of the standard event status register.

\*OPC, \*OPC? (operation complete) sets the standard event status register to monitor the completion of all commands. The query stops

any new commands from being processed until the current processing is complete, then returns a '1'.

\*PSC, \*PSC? (power-on state clear) sets the power-on state so that it clears the service request enable register and the event status enable register at power on.

\*SRE, \*SRE? (service request enable) sets and queries the value of the service request enable register.

\*STB? (status byte) queries the value of the status byte register without erasing its contents.

## How to Use the Status Registers

A program often needs to be able to detect and manage error conditions or changes in instrument status. There are two methods you can use to programmatically access the information in status registers:

- **The polling method**
- **The service request (SRQ) method**

In the polling method, the instrument has a passive role. It only tells the controller that conditions have changed when the controller asks the right question. In the SRQ method, the instrument takes a more active role. It tells the controller when there has been a condition change without the controller asking. Either method allows you to monitor one or more conditions.

The polling method works well if you do not need to know about changes the moment they occur. The SRQ method should be used if you must know immediately when a condition changes. To detect a change using the polling method, the program must repeatedly read the registers.

Use the SRQ method when:

- you need time-critical notification of changes
- you are monitoring more than one device which supports SRQs
- you need to have the controller do something else while waiting
- you can't afford the performance penalty inherent to polling

Use polling when:

- your programming language/development environment does not support SRQ interrupts
- you want to write a simple, single-purpose program and don't want the added complexity of setting up an SRQ handler

To monitor a condition:

1. Determine which register contains the bit that reports the condition.
2. Send the unique SCPI query that reads that register.
3. Examine the bit to see if the condition has changed.

You can monitor conditions in different ways.

- Check the current instrument hardware and firmware status.

Do this by querying the condition registers which continuously monitor status. These registers represent the current state of the instrument. Bits in a condition register are updated in real time. When the condition monitored by a particular bit becomes true, the bit is set to 1. When the condition becomes false, the bit is reset to 0.

- Monitor a particular condition (bit).

You can enable a particular bit(s), using the event enable register. The instrument will then monitor that particular condition(s). If the bit becomes true (0 to 1 transition) in the event register, it will stay set until the event register is cleared. Querying the event register allows you to detect that this condition occurred even if the condition no longer exists. The event register can only be cleared by querying it or sending the \*CLS command.

- Monitor a particular type of change in a condition (bit).
  - The transition registers are preset to register if the condition goes from 0 to 1 (false to true, or a positive transition).
  - This can be changed so the selected condition is detected if the bit goes from 1 to 0 (true to false, or a negative transition).
  - It can also be set for both types of transitions occurring.
  - Or it can be set for neither transition. If both transition registers are set to 0 for a particular bit position, that bit will not be set in the event register for either type of change.

## Using a Status Register

Each bit in a register is represented by a numerical value based on its location. See [Figure 4-1](#) below. This number is sent with the command to enable a particular bit. If you want to enable more than one bit, you would send the sum of all the bits that you want to monitor.

For example, to enable bit 0 and bit 6 of standard event status register, you would send the command \*ESE 65 because  $1 + 64 = 65$ .

The results of a query are evaluated in a similar way. If the \*STB? command returns a decimal value of 140, ( $140 = 128 + 8 + 4$ ) then bit 7 is true, bit 3 is true and bit 2 is true.



**Figure 4-1** Status Register Bit Values

Decimal Value																		
			32768	16384	8192	4096	2048	1024	512	256	128	64	32	16	8	4	2	1
Bit Number	15	14	13	12	11	10	9	8	7	6	5	4	3	2	1	0		

**NOTE** Bit 15 is not used to report status.

### Using the Service Request (SRQ) Method

Your language, bus and programming environment must be able to support SRQ interrupts. (For example, BASIC used with the GPIB.) SRQ is available on SICL LAN, USB, and GPIB. When you monitor a condition with the SRQ method, you must:

1. Determine which bit monitors the condition.
2. Determine how that bit reports to the request service (RQS) bit of the status byte.
3. Send GPIB commands to enable the bit that monitors the condition and to enable the summary bits that report the condition to the RQS bit.
4. Enable the controller to respond to service requests.

When the condition changes, the instrument sets its RQS bit and the GPIB SRQ line. The controller is informed of the change as soon as it occurs. As a result, the time the controller would otherwise have used to monitor the condition can be used to perform other tasks. Your program determines how the controller responds to the SRQ.

### Generating a Service Request

To use the SRQ method, you must understand how service requests are generated. Bit 6 of the status byte register is the request service (RQS) bit. The \*SRE command is used to configure the RQS bit to report changes in instrument status. When such a change occurs, the RQS bit is set. It is cleared when the status byte register is queried using \*SRE? (with a serial poll.) It can be queried without erasing the contents with \*STB?.

When a register set causes a summary bit in the status byte to change from 0 to 1, the instrument can initiate the service request (SRQ)

process. However, the process is only initiated if both of the following conditions are true:

- The corresponding bit of the service request enable register is also set to 1.
- The instrument does not have a service request pending. (A service request is considered to be pending between the time the instrument's SRQ process is initiated and the time the controller reads the status byte register.)

The SRQ process sets the GPIB SRQ line true. It also sets the status byte's request service (RQS) bit to 1. Both actions are necessary to inform the controller that the instrument requires service. Setting the SRQ line only informs the controller that some device on the bus requires service. Setting the RQS bit allows the controller to determine which instrument requires service.

If your program enables the controller to detect and respond to service requests, it should instruct the controller to perform a serial poll when the GPIB SRQ line is set true. Each device on the bus returns the contents of its status byte register in response to this poll. The device whose RQS bit is set to 1 is the device that requested service.

---

**NOTE** When you read the instrument's status byte register with a serial poll, the RQS bit is reset to 0. Other bits in the register are not affected.

---

**NOTE** If the status register is configured to SRQ on end-of-measurement and the measurement is in continuous mode, then restarting a measurement (INIT command) can cause the measuring bit to pulse low. This causes an SRQ when you have not actually reached the "end-of-measurement" condition. To avoid this:

1. Set INITiate:CONTinuous off.
2. Set/enable the status registers.
3. Restart the measurement (send INIT).

---

## PSA Core Status Register System (Page 1 of 2)

Some measurement personality **Modes** use the status register system more like the E4406A. These include Basic Mode, NADC/PDC, GSM/EDGE, cdmaOne, cdma2000/1xEV-DV, W-CDMA/HSDPA and 1xEV-DO. See “E4406A Core Status Register System” on page 125.

### Preset Values

- For All Registers: (-) Transition Filter = 0's  
(+) Transition Filter = 1's
- For STAT:QUES, STAT:OPER, & all OPER:INST:ISUM registers: Event Enable = 0's
- For all Other Registers: Event Enable = 1's
- Unused: All unused bits = 0

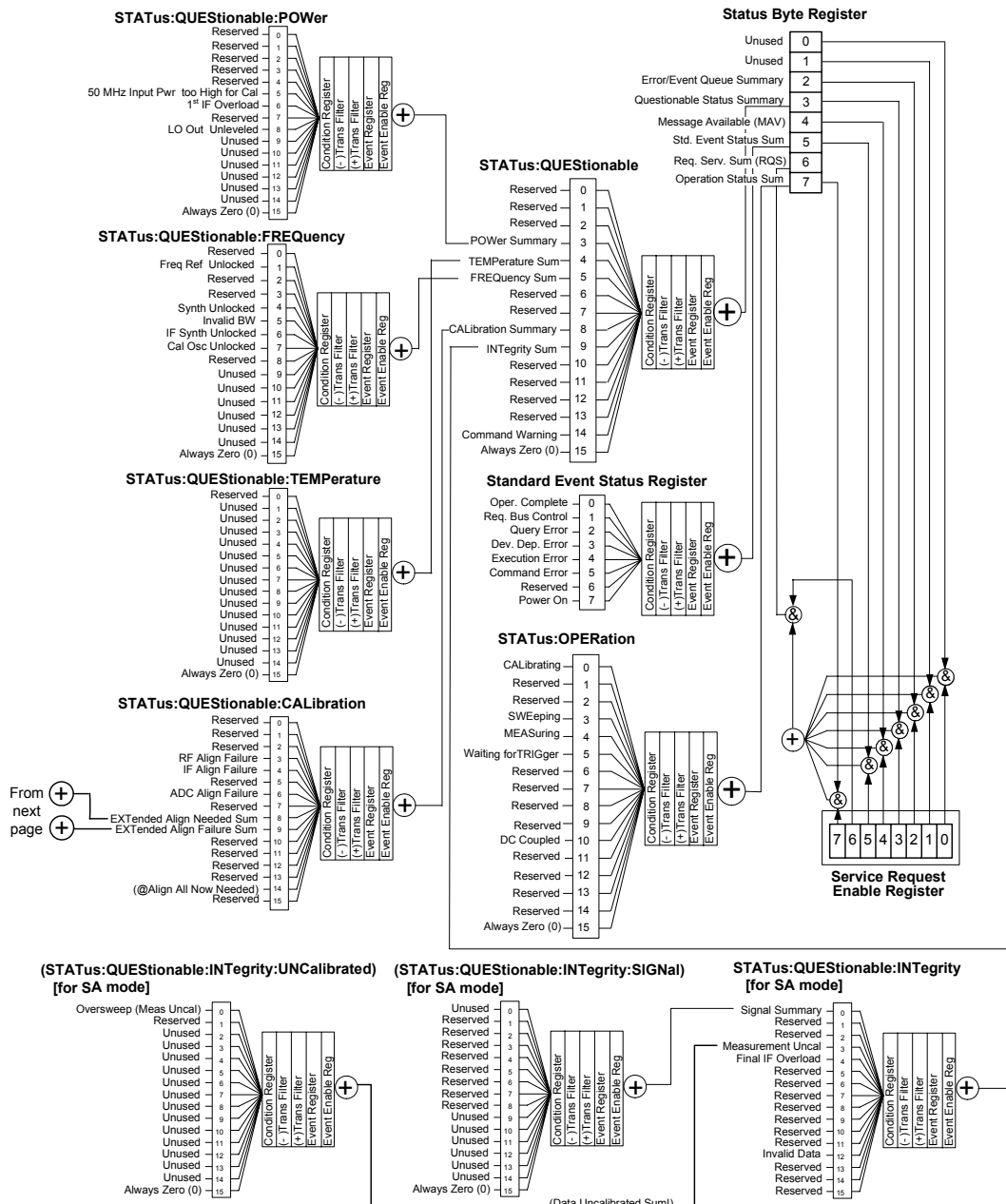

PSA Core Status Register System (Page 2 of 2)

(@#STATus:QUEStionable:CALibration:EXTEnded:FAILure)

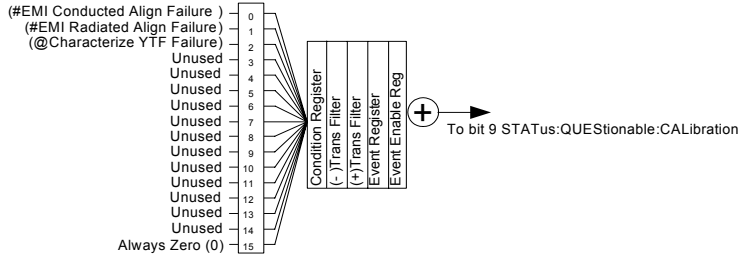

(@#STATus:QUEStionable:CALibration:EXTEnded:NEEDED)

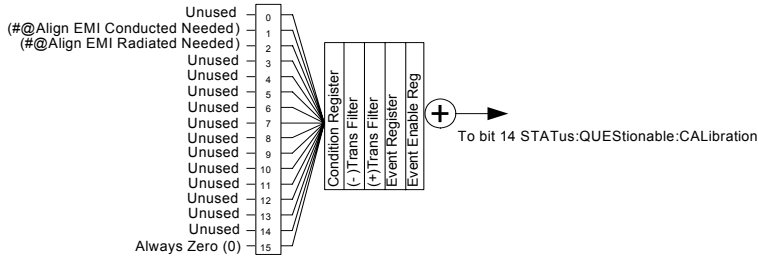

## E4406A Core Status Register System

### Preset Values

For All Registers: (-) Transition Filter = 0's  
(+) Transition Filter = 1's  
For STAT:QUES, STAT:OPER, & all OPER:INST:ISUM registers: Event Enable = 0's  
For all Other Registers: Event Enable = 1's  
Unused: All unused bits = 0

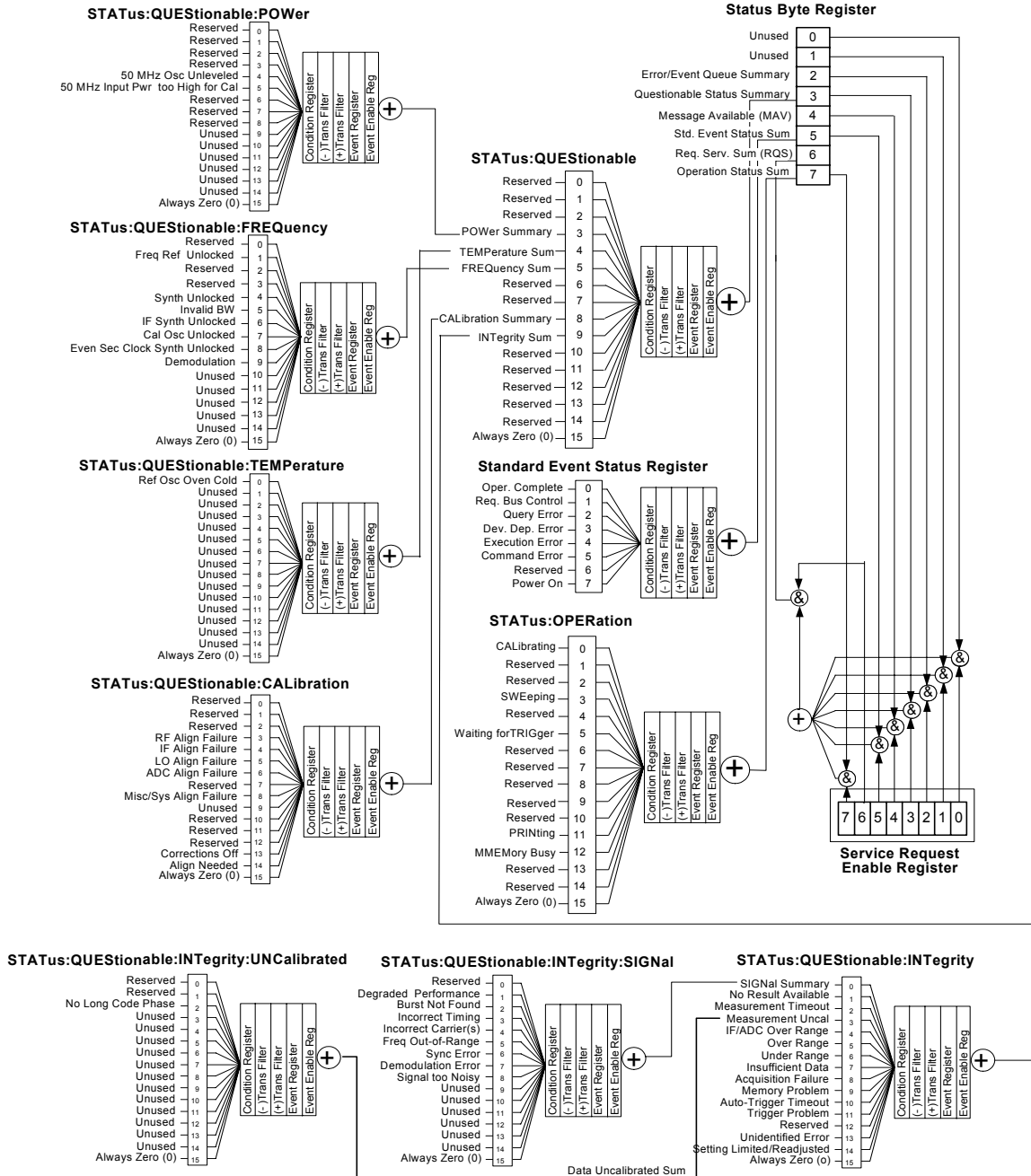

## Status Byte Register

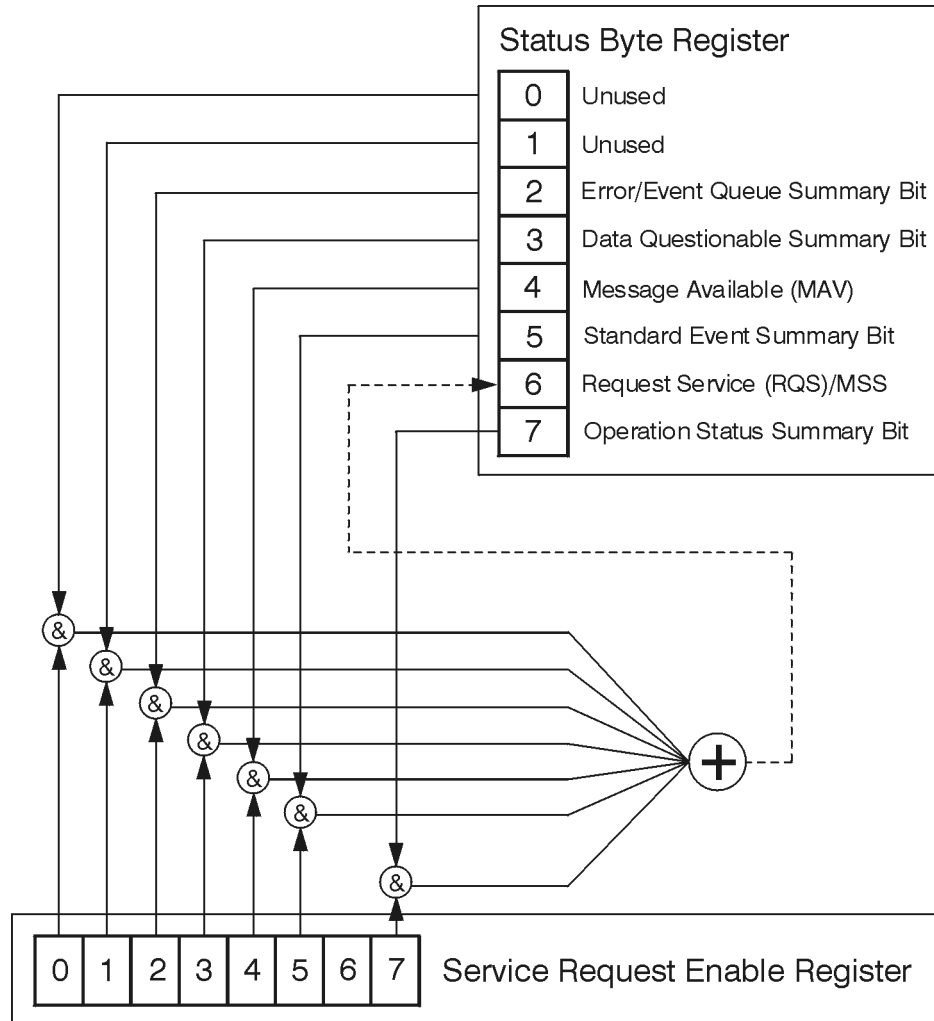

ck776a

The RQS bit is read and reset by a serial poll. The same bit position (MSS) is read, non-destructively by the \*STB? command. If you serial poll bit 6 it is read as RQS, but if you send \*STB it reads bit 6 as MSS. For more information refer to IEEE 488.2 standards, section 11.

	<b>Description</b>	Standard Operation Status Summary Bit	Request Service (RQS) Summary Bit	Standard Event Status Summary Bit	Message Available (MAV)	Data Questionable Status Summary Bit	Error/Event Queue Summary Bit	Unused	Unused
<b>Bit Number</b>	7	6	5	4	3	2	1	0	

\*STB?

### Status Byte Register

ck725a

Bit	Description
0, 1	These bits are always set to 0.
2	A 1 in this bit position indicates that the SCPI error queue is not empty which means that it contains at least one error message.
3	A 1 in this bit position indicates that the data questionable summary bit has been set. The data questionable event register can then be read to determine the specific condition that caused this bit to be set.
4	A 1 in this bit position indicates that the instrument has data ready in the output queue. There are no lower status groups that provide input to this bit.
5	A 1 in this bit position indicates that the standard event summary bit has been set. The standard event status register can then be read to determine the specific event that caused this bit to be set.
6	A 1 in this bit position indicates that the instrument has at least one reason to report a status change. This bit is also called the master summary status bit (MSS).
7	A 1 in this bit position indicates that the standard operation summary bit has been set. The standard operation event register can then be read to determine the specific condition that caused this bit to be set.

To query the status byte register, send the command \*STB? The response will be the *decimal* sum of the bits which are set to 1. For

example, if bit number 7 and bit number 3 are set to 1, the decimal sum of the 2 bits is 128 plus 8. So the decimal value 136 is returned. The \*STB command does not clear the status register

In addition to the status byte register, the status byte group also contains the service request enable register. This register lets you choose which bits in the status byte register will trigger a service request.

Send the \*SRE <number> command where <number> is the sum of the decimal values of the bits you want to enable plus the decimal value of bit 6. For example, assume that you want to enable bit 7 so that whenever the standard operation status register summary bit is set to 1 it will trigger a service request. Send the command \*SRE 192 (because  $192 = 128 + 64$ ). You must always add 64 (the numeric value of RQS bit 6) to your numeric sum when you enable any bits for a service request. The command \*SRE? returns the decimal value of the sum of the bits previously enabled with the \*SRE <number> command.

The service request enable register presets to zeros (0).

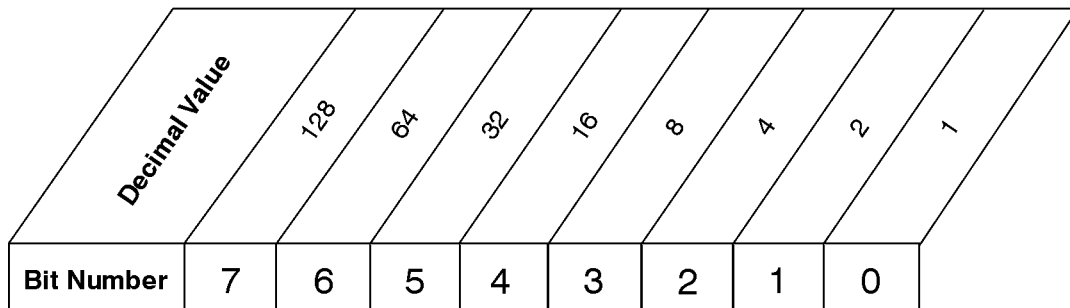

\*SRE <num>  
\*SRE?

### Service Request Enable Register

ck726a



## Standard Event Status Register

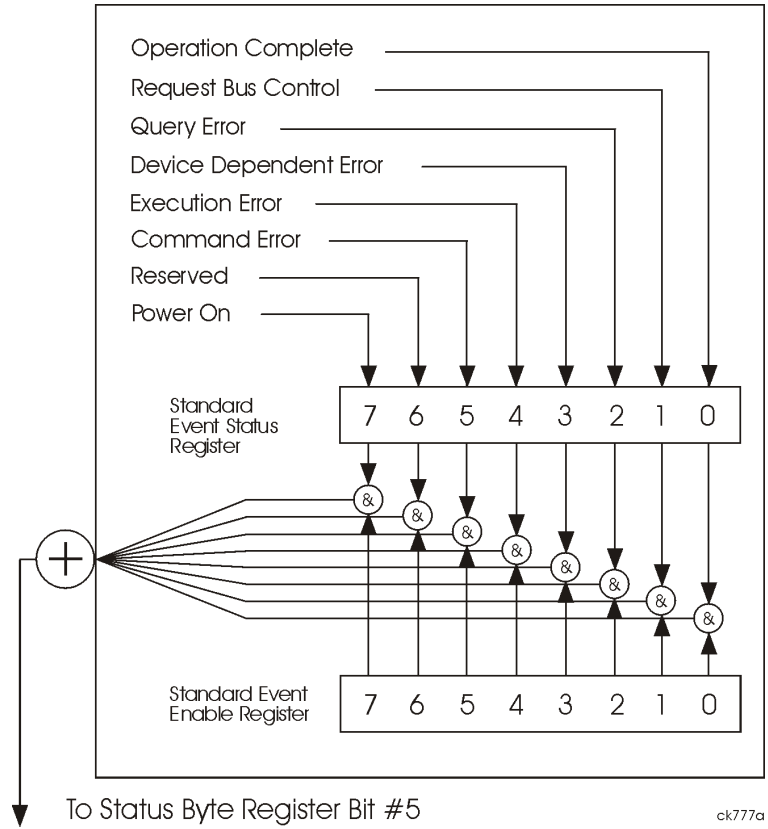

The standard event status register contains the following bits:

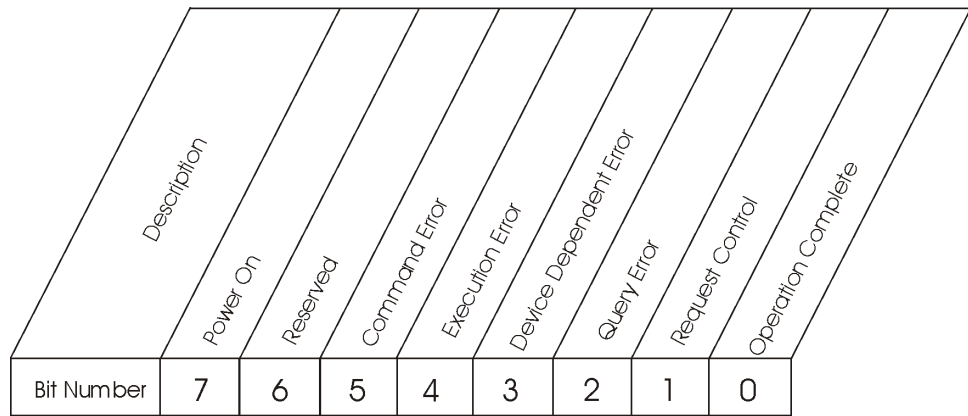

\*ESR?

Standard Event Status Register

ck727a

Bit	Description
0	A 1 in this bit position indicates that all pending operations were completed following execution of the *OPC command.
1	This bit is always set to 0. (The instrument does not request control.)
2	A 1 in this bit position indicates that a query error has occurred. Query errors have SCPI error numbers from -499 to -400.
3	A 1 in this bit position indicates that a device dependent error has occurred. Device dependent errors have SCPI error numbers from -399 to -300 and 1 to 32767.
4	A 1 in this bit position indicates that an execution error has occurred. Execution errors have SCPI error numbers from -299 to -200.
5	A 1 in this bit position indicates that a command error has occurred. Command errors have SCPI error numbers from -199 to -100.
6	Reserved
7	A 1 in this bit position indicates that the instrument has been turned off and then on.

The standard event status register is used to determine the specific event that set bit 5 in the status byte register. To query the standard event status register, send the command \*ESR?. The response will be the *decimal* sum of the bits which are enabled (set to 1). For example, if bit number 7 and bit number 3 are enabled, the decimal sum of the 2 bits is 128 plus 8. So the decimal value 136 is returned.

In addition to the standard event status register, the standard event status group also contains a standard event status enable register. This register lets you choose which bits in the standard event status register will set the summary bit (bit 5 of the status byte register) to 1. Send the \*ESE <number> command where <number> is the sum of the decimal values of the bits you want to enable. For example, to enable bit 7 and bit 4 so that whenever either of those bits is set to 1, the standard event status summary bit of the status byte register will be set to 1, send the command \*ESE 144 (128 + 16). The command \*ESE? returns the decimal value of the sum of the bits previously enabled with the \*ESE <number> command.

The standard event status enable register presets to zeros (0).

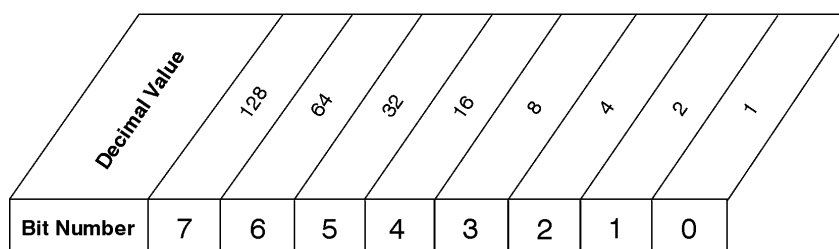

\*ESE <num>  
\*ESE?

Standard Event Status Enable Register

ck728a

## Operation and Questionable Status Registers

The operation and questionable status registers are registers that monitor the overall instrument condition. They are accessed with the `STATUS:OPERation` and `STATUS:QUEStionable` commands in the `STATUS` command subsystem. See the Section “E4406A Core Status Register System” on page 125 “PSA Core Status Register System (Page 1 of 2)” on page 123.

### Operation Status Register

The operation status register monitors the current instrument measurement state. It checks to see if the instrument is calibrating, sweeping, or waiting for a trigger. For more information see the `*OPC?` command located in the IEEE Common Commands section.

Bit	Condition	Operation
0	Calibrating	The instrument is busy executing its automatic alignment process
3	Sweeping	The instrument is busy taking a sweep.
5	Waiting for trigger	The instrument is waiting for the trigger conditions to be met, then it will trigger a sweep or measurement.

### Questionable Status Register

The questionable status register monitors the instrument’s condition to see if anything questionable has happened to it. It is looking for anything that might cause an error or a bad measurement like a hardware problem, an out of calibration situation, or a unusual signal. All the bits are summary bits from lower-level event registers.

Bit	Condition	Operation
3	Power summary	The instrument hardware has detected a power unlevelled condition.
4	Temperature summary	The instrument is still warming up.
5	Frequency summary	The instrument hardware has detected an unlocked condition or a problem with the external frequency reference.
8	Calibration summary	The instrument has detected a hardware problem while doing the automatic internal alignment process.
9	Integrity summary	The instrument has detected a questionable measurement condition such as: bad timing, bad signal/data, timeout problem, signal overload, or “meas uncal”.



- CFIT or curve fit - applies curve fitting routines to the data. <soffset> and <length> are required to define the data that you want. <roffset> is an optional parameter for the desired order of the curve equation. The query will return the following values: the x-offset (in seconds) and the curve coefficients ((order + 1) values).

MAX, MEAN, MIN, RMS, SAMP, SDEV and PPH return one data value for each specified region (or <length>) of trace data, for as many regions as possible until you run out of trace data (using <roffset> to specify regions). Or they return the number regions you specify (using <rlimit>) ignoring any data beyond that.

- MAXimum - returns the maximum data point for the specified region(s) of trace data. For I/Q trace data, the maximum magnitude of the I/Q pairs is returned.
- MEAN - returns the arithmetic mean of the data point values for the specified region(s) of trace data. See [“Mean Value of Data Points for Specified Region\(s\)” on page 133](#). For I/Q trace data, the mean of the magnitudes of the I/Q pairs is returned. See [“Mean Value of I/Q Data Pairs for Specified Region\(s\)” on page 133](#).

Note: If the original trace data is in dB, this function returns the arithmetic mean of those log values, not log of the mean power, which is a more useful value.

**Equation 4-1 Mean Value of Data Points for Specified Region(s)**

$$\text{MEAN} = \frac{1}{n} \sum_{X_i \in \text{region}(s)} X_i$$

where  $X_i$  is a data point value, and  $n$  is the number of data points in the specified region(s).

**Equation 4-2 Mean Value of I/Q Data Pairs for Specified Region(s)**

$$\text{MEAN} = \frac{1}{n} \sum_{X_i \in \text{region}(s)} |X_i|$$

where  $|X_i|$  is the magnitude of an I/Q pair, and  $n$  is the number of I/Q pairs in the specified region(s).

- MINimum - returns the minimum data point for the specified region(s) of trace data For I/Q trace data, the minimum magnitude of

the I/Q pairs is returned.

- **RMS** - returns the arithmetic rms of the data point values for the specified region(s) of trace data. See “[RMS Value of Data Points for Specified Region\(s\)](#)” on page 134.

For I/Q trace data, the rms of the magnitudes of the I/Q pairs is returned. See “[RMS Value of I/Q Data Pairs for Specified Region\(s\)](#)” on page 134.

Note: This function is very useful for I/Q trace data. However, if the original trace data is in dB, this function returns the rms of the log values which is not usually needed.

**Equation 4-3 RMS Value of Data Points for Specified Region(s)**

$$\text{RMS} = \sqrt{\frac{1}{n} \sum_{X_i \in \text{region}(s)} X_i^2}$$

where  $X_i$  is a data point value, and  $n$  is the number of data points in the specified region(s).

**Equation 4-4 RMS Value of I/Q Data Pairs for Specified Region(s)**

$$\text{RMS} = \sqrt{\frac{1}{n} \sum_{X_i \in \text{region}(s)} X_i X_i^*}$$

where  $X_i$  is the complex value representation of an I/Q pair,  $X_i^*$  its conjugate complex number, and  $n$  is the number of I/Q pairs in the specified region(s).

Once you have the rms value for a region of I/Q trace data, you may want to calculate the mean power. You must convert this rms I/Q value (peak volts) to power in dB.

$$10 \times \log[10 \times (\text{rms value})^2]$$

- **SAMPlE** - returns the first data value for the specified region(s) of trace data. For I/Q trace data, the first I/Q pair is returned.
- **SDEViation** - returns the arithmetic standard deviation for the data point values for the specified region(s) of trace data. See “[Standard Deviation of Data Point Values for Specified Region\(s\)](#)” on page 135.

For I/Q trace data, the standard deviation of the magnitudes of the I/Q pairs is returned. See “[Standard Deviation of I/Q Data Pair Values for Specified Region\(s\)](#)” on page 135.

**Equation 4-5 Standard Deviation of Data Point Values for Specified Region(s)**

$$\text{SDEV} = \sqrt{\frac{1}{n} \sum_{X_i \in \text{region}(s)} (X_i - \bar{X})^2}$$

where  $X_i$  is a data point value,  $\bar{X}$  is the arithmetic mean of the data point values for the specified region(s), and  $n$  is the number of data points in the specified region(s).

**Equation 4-6 Standard Deviation of I/Q Data Pair Values for Specified Region(s)**

$$\text{SDEV} = \sqrt{\frac{1}{n} \sum_{X_i \in \text{region}(s)} (|X_i| - \bar{X})^2}$$

where  $|X_i|$  is the magnitude of an I/Q pair,  $\bar{X}$  is the mean of the magnitudes for the specified region(s), and  $n$  is the number of data points in the specified region(s).

- PPH - returns the pairs of rms power (dBm) and arithmetic mean phase (radian) for every specified region and frequency offset (Hz). The number of pairs is defined by the specified number of regions. Assuming this command can be used for I/Q vector (n=0) in Waveform (time domain) measurement and all parameters are specified by data point in PPH.

The rms power of the specified region may be expressed as:

$$\text{Power} = 10 \times \log [10 \times (\text{RMS I/Q value})] + 10.$$

$$\text{The RMS I/Q value (peak volts)} = \sqrt{\frac{1}{n} \sum_{X_i \in \text{region}} X_i X_i^*}$$

where  $X_i$  is the complex value representation of an I/Q pair,  $X_i^*$  its conjugate complex number, and  $n$  is the number of I/Q pairs in the specified region.

The arithmetic mean phase of the specified region may be expressed as:

$$\text{Phase} = \frac{1}{n} \sum_{Y_i \in \text{region}} Y_i$$

Where  $Y_i$  is the unwrapped phase of I/Q pair with applying frequency correction and  $n$  is the number of I/Q pairs in the specified region.

The frequency correction is made by the frequency offset calculated by the arithmetic mean of every specified region's frequency offset. Each frequency offset is calculated by the least square method against the unwrapped phase of I/Q pair.

**Figure 4-2 Sample Trace Data - Constant Envelope**

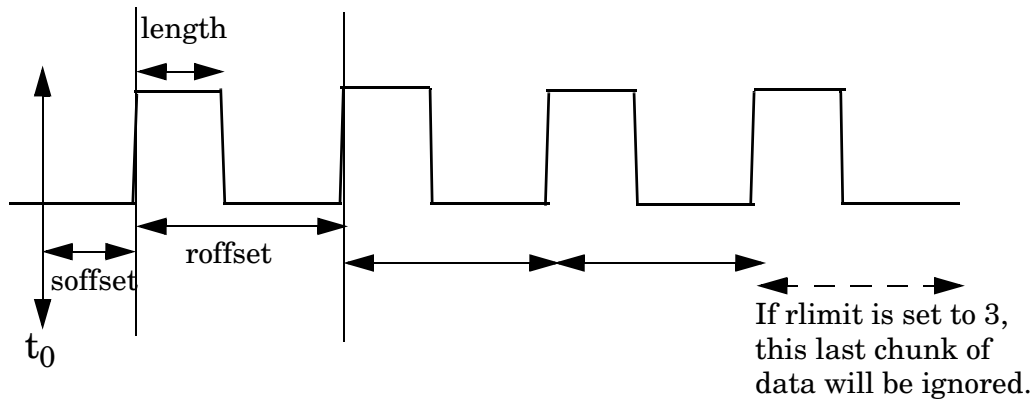

**Figure 4-3 Sample Trace Data - Not Constant Envelope**

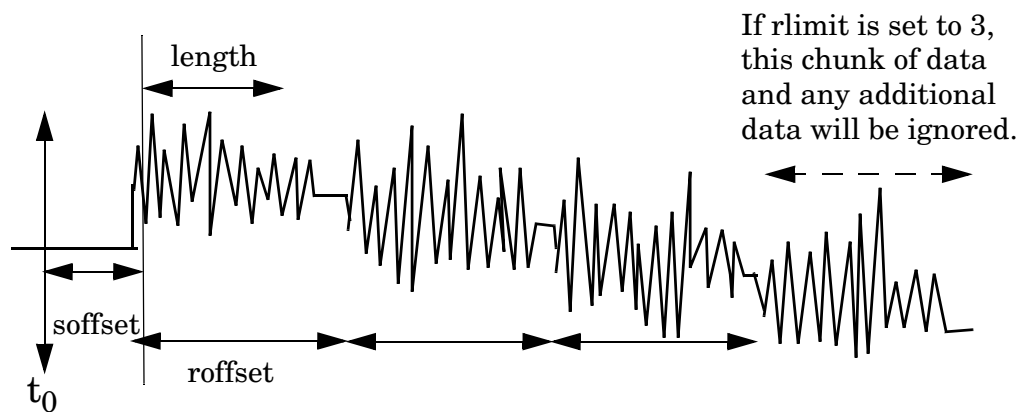

<soffset> - start offset is an optional real number (in seconds). It specifies the amount of data at the beginning of the trace that will be ignored before the decimation process starts. It is the time from the start of the trace to the point where you want to start using the data. The default value is zero.



<length> - is an optional real number (in seconds). It defines how much data will be compressed into one value. This parameter has a default value equal to the current trace length.

<roffset> - repeat offset is an optional real number (in seconds). It defines the beginning of the next field of trace elements to be compressed. This is relative to the beginning of the previous field. This parameter has a default value equal to the <length> variable.

<rlimit> - repeat limit is an optional integer. It specifies the number of data items that you want returned. It will ignore any additional items beyond that number. You can use the Start offset and the Repeat limit to pick out exactly what part of the data you want to use. The default value is all the data.

Example: To query the mean power of a set of GSM bursts:

1. Set the waveform measurement sweep time to acquire at least one burst.
2. Set the triggers such that acquisition happens at a known position relative to a burst.
3. Then query the mean burst levels using,  
**CALC:DATA2:COMP? MEAN, 24e-6, 526e-6** (These parameter values correspond to GSM signals, where 526e-6 is the length of the burst in the slot and you just want 1 burst.)

---

**NOTE** There is a more detailed example in the “Improving the Speed of Your Measurements” section in the PSA Series *User’s and Programmer’s Reference*. There is also a sample program in the Programming Fundamentals chapter of that book, and a copy of it is on the documentation CD-ROM.

---

Remarks: The optional parameters must be entered in the specified order. For example, if you want to specify <length>, you must also specify <soffset>.

This command uses the data in the format specified by FORMat:DATA, returning either binary or ASCII data.

History: Added in revision A.03.00

Added in revision A.03.00

Changed in revision A.05.00

Measurement	Available Traces	Markers Available?
ACP - adjacent channel power (Basic, cdmaOne, cdma2000, W-CDMA, iDEN, NADC, PDC modes)	no traces (n=0) <sup>a</sup> for I/Q points	no markers
BER - bit error rate (iDEN mode)	no traces (n=0) <sup>a</sup> for I/Q data	no markers

Measurement	Available Traces	Markers Available?
CDPower - code domain power (cdmaOne mode)	POWer ( $n=2$ ) <sup>a</sup> TIMing ( $n=3$ ) <sup>a</sup> PHASe ( $n=4$ ) <sup>a</sup> ( $n=0$ ) <sup>a</sup> for I/Q points	yes
CDPower - code domain power (cdma2000, W-CDMA modes)	CDPower ( $n=2$ ) <sup>a</sup> EVM ( $n=5$ ) <sup>a</sup> MERRor ( $n=6$ ) <sup>a</sup> PERRor ( $n=7$ ) <sup>a</sup> SPOWer ( $n=9$ ) <sup>a</sup> CPOWer ( $n=10$ ) <sup>a</sup> ( $n=0$ ) <sup>a</sup> for I/Q points	yes
CHPower - channel power (Basic, cdmaOne, cdma2000, W-CDMA modes)	SPECTrum ( $n=2$ ) <sup>a</sup> ( $n=0$ ) <sup>a</sup> for I/Q points	no markers
CSPur - spurs close (cdmaOne mode)	SPECTrum ( $n=2$ ) <sup>a</sup> ULIMit ( $n=3$ ) <sup>a</sup> ( $n=0$ ) <sup>a</sup> for I/Q points	yes
EEVM - EDGE error vector magnitude (EDGE mode)	EVMerror ( $n=2$ ) <sup>a</sup> MERRor ( $n=3$ ) <sup>a</sup> PERRor ( $n=4$ ) <sup>a</sup> ( $n=0$ ) <sup>a</sup> for I/Q points	yes
EORFspectr - EDGE output RF spectrum (EDGE mode)	RFEMod ( $n=2$ ) <sup>a</sup> RFESwitching ( $n=3$ ) <sup>a</sup> SPEMod ( $n=4$ ) <sup>a</sup> LIMMod ( $n=5$ ) <sup>a</sup> ( $n=0$ ) <sup>a</sup> for I/Q points	yes, only for a single offset  yes, only for multiple offsets
EPVTime - EDGE power versus time (EDGE mode)	RFENvelope ( $n=2$ ) <sup>a</sup> UMASk ( $n=3$ ) <sup>a</sup> LMASk ( $n=4$ ) <sup>a</sup> ( $n=0$ ) <sup>a</sup> for I/Q points	yes

Measurement	Available Traces	Markers Available?
ETSPur - EDGE transmit band spurs (EDGE mode)	SPECTrum ( $n=2$ ) <sup>a</sup> ULIMit ( $n=3$ ) <sup>a</sup> ( $n=0$ ) <sup>a</sup> for I/Q points	yes
EVM - error vector magnitude (NADC, PDC modes)	EVM ( $n=2$ ) <sup>a</sup> MERRor ( $n=3$ ) <sup>a</sup> PERRor ( $n=4$ ) <sup>a</sup> ( $n=0$ ) <sup>a</sup> for I/Q points	yes
EVMQpsk - QPSK error vector magnitude (cdma2000, W-CDMA modes)	EVM ( $n=2$ ) <sup>a</sup> MERRor ( $n=3$ ) <sup>a</sup> PERRor ( $n=4$ ) <sup>a</sup> ( $n=0$ ) <sup>a</sup> for I/Q points	yes
IM - intermodulation (cdma2000, W-CDMA modes)	SPECTrum ( $n=2$ ) <sup>a</sup> ( $n=0$ ) <sup>a</sup> for I/Q points	yes
MCPower - multi-carrier power (W-CDMA mode)	no traces ( $n=0$ ) <sup>a</sup> for I/Q points	no markers
OBW - occupied bandwidth (cdmaOne, cdma2000, iDEN, PDC, W-CDMA modes)	no traces ( $n=0$ ) <sup>a</sup> for I/Q points	no markers
ORFSpectrum - output RF spectrum (GSM, EDGE mode)	RFEMod ( $n=2$ ) <sup>a</sup> RFESwitching ( $n=3$ ) <sup>a</sup> SPEMod ( $n=4$ ) <sup>a</sup> LIMMod ( $n=5$ ) <sup>a</sup> ( $n=0$ ) <sup>a</sup> for I/Q points	yes, only for a single offset  yes, only for multiple offsets
PFERror - phase and frequency error (GSM, EDGE mode)	PERRor ( $n=2$ ) <sup>a</sup> PFERror ( $n=3$ ) <sup>a</sup> RFENvelope ( $n=4$ ) <sup>a</sup> ( $n=0$ ) <sup>a</sup> for I/Q points	yes
PStatistic - power statistics CCDF (Basic, cdma2000, W-CDMA modes)	MEASured ( $n=2$ ) <sup>a</sup> GAUSian ( $n=3$ ) <sup>a</sup> REFerence ( $n=4$ ) <sup>a</sup> ( $n=0$ ) <sup>a</sup> for I/Q points	yes

Measurement	Available Traces	Markers Available?
PVTime - power versus time (GSM, EDGE, Service modes)	RFENvelope ( $n=2$ ) <sup>a</sup> UMASk ( $n=3$ ) <sup>a</sup> LMASk ( $n=4$ ) <sup>a</sup> ( $n=0$ ) <sup>a</sup> for I/Q points	yes
RHO - modulation quality (cdmaOne, cdma2000, W-CDMA mode)	( $n=0$ ) <sup>a</sup> for I/Q points EVM ( $n=2$ ) <sup>a</sup> MERRor ( $n=3$ ) <sup>a</sup> PERRor ( $n=4$ ) <sup>a</sup> ( $n=0$ ) <sup>a</sup> for I/Q points	yes
SEMask - spectrum emissions mask (cdma2000, W-CDMA mode)	SPECTrum ( $n=2$ ) <sup>a</sup> ( $n=0$ ) <sup>a</sup> for I/Q points	yes
TSPur - transmit band spurs (GSM, EDGE mode)	SPECTrum ( $n=2$ ) <sup>a</sup> ULIMit ( $n=3$ ) <sup>a</sup> ( $n=0$ ) <sup>a</sup> for I/Q points	yes
TXPower - transmit power (GSM, EDGE mode)	RFENvelope ( $n=2$ ) <sup>a</sup> IQ ( $n=8$ ) <sup>a</sup> ( $n=0$ ) <sup>a</sup> for I/Q points	yes
SPECTrum - (frequency domain) (all modes)	RFENvelope ( $n=2$ ) <sup>a</sup> for Service mode IQ ( $n=3$ ) <sup>a</sup> SPECTrum ( $n=4$ ) <sup>a</sup> ASPEctrum ( $n=7$ ) <sup>a</sup> ( $n=0$ ) <sup>a</sup> for I/Q points	yes
WAVEform - (time domain) (all modes)	RFENvelope ( $n=2$ ) <sup>a</sup> (also for Signal Envelope trace) IQ ( $n=5$ ) <sup>a</sup> ( $n=0$ ) <sup>a</sup> for I/Q points	yes

a. The  $n$  number indicates the sub-opcode that corresponds to this trace. Detailed descriptions of the trace data can be found in the MEASure subsystem documentation by looking up the sub-opcode for the appropriate measurement.

## Calculate Peaks of Trace Data

**:CALCulate:DATA<n>:PEAKs?**  
**<threshold>,<excursion>[,AMPLitude|FREQuency|TIME]**

Returns a list of peaks for the designated trace data *n* for the currently selected measurement. The peaks must meet the requirements of the peak threshold and excursion values.

The command can only be used with specific *<n>* (sub-opcode) values, for measurement results that are trace, or scalar, data. See the table above for the appropriate sub-opcodes. Both real and complex traces can be searched, but complex traces are converted to magnitude in dBm. Sub-opcode *n=0*, is the raw trace data which cannot be searched for peaks. Sub-opcode *n=1*, is the scalar data which also cannot be searched for peaks.

Threshold - is the level below which trace data peaks are ignored

Excursion - To be defined as a peak, the signal must rise above the threshold by a minimum amplitude change (excursion). Excursion is measured from the lowest point above the threshold (of the rising edge of the peak), to the highest signal point that begins the falling edge. If a signal valley is higher than the threshold, then the excursion is referenced to that valley, and a peak is only defined if the signal following that valley exceeds the excursion.

Amplitude - lists the peaks in order of descending amplitude, so the highest peak is listed first. This is the default peak order listing if the optional parameter is not specified.

Frequency - lists the peaks in order of occurrence, left to right across the x-axis

Time - lists the peaks in order of occurrence, left to right across the x-axis

Example: Select the spectrum measurement.

Use **CALC:DATA4:PEAK? -40,10,FREQ** to identify the peaks above -40 dBm, with excursions of at least 10 dB, in order of increasing frequency.

Query Results: Returns a list of floating-point numbers. The first value in the list is the number of peak points that follow. A peak point consists of two values: a peak amplitude followed by the its corresponding frequency (or time).

If no peaks are found the peak list will consist of only the number of peaks, (0).

The peak list is limited to 100 peaks. Peaks in excess of 100 are ignored.

Remarks: This command uses the data setting specified by the

FORMat:DATA command and can return real 32-bit, real 64-bit, or ASCII data. The default data format is ASCII.

## **CALCulate:MARKers Subsystem**

Markers can be put on your displayed measurement data to supply information about specific points on the data. Some of the things that markers can be used to measure include: precise frequency at a point, minimum or maximum amplitude, and the difference in amplitude or frequency between two points.

When using the marker commands you must specify the measurement in the SCPI command. We recommend that you use the marker commands only on the current measurement. Many marker commands will return invalid results, when used on a measurement that is not current. (This is true for commands that do more than simply setting or querying an instrument parameter.) No error is reported for these invalid results.

You must make sure that the measurement is completed before trying to query the marker value. Using the MEASure or READ command, before the marker command, forces the measurement to complete before allowing the next command to be executed.

Each measurement has its own instrument state for marker parameters. Therefore, if you exit the measurement, the marker settings in each measurement are saved and are then recalled when you change back to that measurement.

### **Basic Mode - <measurement> key words**

- CCDF - markers available
- SPECTrum - markers available
- WAVeform - markers available

### **Example:**

Suppose you are using the Spectrum measurement in your measurement personality. To position marker 2 at the maximum peak value of the trace that marker 2 is currently on, the command is:

```
:CALCulate:SPECTrum:MARKer2:MAXimum
```

You must make sure that the measurement is completed before trying to query the marker value. Use the MEASure or READ command before using the marker command. This forces the measurement to complete before allowing the next command to be executed.

## Markers All Off on All Traces

**:CALCulate:<measurement>:MARKer:AOff**

Turns off all markers on all the traces in the specified measurement.

Example:       **CALC:SPEC:MARK:AOff**

Remarks:       The keyword for the current measurement must be specified in the command. (Some examples include: SPECTrum, WAVeform)

Front Panel

Access:         **Marker, More, Marker All Off**

## Marker Function Result

**:CALCulate:<measurement>:MARKer [1] | 2 | 3 | 4:FUNCTION:RESult?**

Queries the result of the currently active marker function. The measurement must be completed before querying the marker. A particular measurement may not have all the types of markers available.

The marker must have already been assigned to a trace. Use

**:CALCulate:<measurement>:MARKer [1] | 2 | 3 | 4:TRACe** to assign a marker to a particular trace.

Example:       **CALC:SPEC:MARK:FUNC:RES?**

Remarks:       The keyword for the current measurement must be specified in the command. (Some examples include: SPECTrum, WAVeform)

Front Panel

Access:         **Marker, Marker Function**

## Marker Peak (Maximum) Search

**:CALCulate:<measurement>:MARKer [1] | 2 | 3 | 4:MAXimum**

Places the selected marker on the highest point on the trace that is assigned to that particular marker number.

The marker must have already been assigned to a trace. Use

**:CALCulate:<measurement>:MARKer [1] | 2 | 3 | 4:TRACe** to assign a marker to a particular trace.

Example:       **CALC:SPEC:MARK1:MAX**

Remarks:       The keyword for the current measurement must be specified in the command. (Some examples include: SPECTrum, WAVeform)



Front Panel  
Access: **Search**

### Marker Peak (Minimum) Search

**:CALCulate:<measurement>:MARKer [1] | 2 | 3 | 4:MINimum**

Places the selected marker on the lowest point on the trace that is assigned to that particular marker number.

The marker must have already been assigned to a trace. Use **:CALCulate:<measurement>:MARKer [1] | 2 | 3 | 4:TRACe** to assign a marker to a particular trace.

Example: **CALC:SPEC:MARK2 MIN**

Remarks: The keyword for the current measurement must be specified in the command. (Some examples include: SPECTrum, WAVeform)

### Marker Mode

*PSA Series (Basic, cdmaOne, cdma2000, W-CDMA, GSM/EDGE, NADC, PDC modes):*

**:CALCulate:<measurement>:MARKer [1] | 2 | 3 | 4:MODE  
POSITION|DELTA**

*PSA Series (Phase Noise mode only):*

**:CALCulate:<measurement>:MARKer [1] | 2 | 3 | 4:MODE  
POSITION|DELTA|RMSDegree|RMSRadian|RFM|RMSJitter|OFF**

**:CALCulate:<measurement>:MARKer [1] | 2 | 3 | 4:MODE?**

Selects the type of marker to be a normal position-type marker or a delta marker. A specific measurement may not have both types of markers. For example, several measurements only have position markers

PSA Phase Noise Mode: Selects the type of marker to be a normal position-type marker, a delta marker or an RMS measurement marker.

The marker must have already been assigned to a trace. Use **:CALCulate:<measurement>:MARKer [1] | 2 | 3 | 4:TRACe** to assign a marker to a particular trace.

Example: **CALC:SPEC:MARK:MODE DELTA**

Remarks: For the delta mode only markers 1 and 2 are valid.  
  
The keyword for the current measurement must be specified in the command. (Some examples include: SPECTrum, WAVeform)

Programming Commands  
**CALCulate Subsystem**

Front Panel

Access: **Marker, Marker [Delta]**

### Marker On/Off

```
:CALCulate:<measurement>:MARKer [1] | 2 | 3 | 4 [:STATe] OFF|ON|0|1
:CALCulate:<measurement>:MARKer [1] | 2 | 3 | 4 [:STATe] ?
```

Turns the selected marker on or off.

The marker must have already been assigned to a trace. Use `:CALCulate:<measurement>:MARKer [1] | 2 | 3 | 4:TRACe` to assign a marker to a particular trace.

Example:        **CALC:SPEC:MARK2: on**

Remarks:        The keyword for the current measurement must be specified in the command. (Some examples include: SPECTrum, AREFERENCE, CFLocation, WAVeform)

The WAVeform measurement only has two markers available.

Front Panel

Access:        **Marker, Select then Marker Normal or Marker On Off**

### Marker to Trace

```
:CALCulate:<measurement>:MARKer [1] | 2 | 3 | 4:TRACe <trace_name>
:CALCulate:<measurement>:MARKer [1] | 2 | 3 | 4:TRACe?
```

Assigns the specified marker to the designated trace. Not all types of measurement data can have markers assigned to them.

Example:        With the WAVeform measurement selected, a valid command is **CALC:SPEC:MARK2:TRACE rfenvelope**.

Range:        The names of valid traces are dependent upon the selected measurement. See the following table for the available trace names. The trace name assignment is independent of the marker number.

Remarks:        The keyword for the current measurement must be specified in the command. (Some examples include: SPECTrum, WAVeform)

Front Panel

Access:        **Marker, Marker Trace**

Measurement	Available Traces	Markers Available?
ACP - adjacent channel power (Basic, cdmaOne, cdma2000, W-CDMA, NADC, PDC modes)	no traces $(n=0)^a$ for I/Q points	no markers
BER - bit error rate	no traces	no markers

Measurement	Available Traces	Markers Available?
CDPower - code domain power (cdmaOne mode)	POWer ( $n=2$ ) <sup>a</sup> TIMing ( $n=3$ ) <sup>a</sup> PHASe ( $n=4$ ) <sup>a</sup> ( $n=0$ ) <sup>a</sup> for I/Q points	yes
CDPower - code domain power (cdma2000, W-CDMA, 1xEV-DO modes)	CDPower ( $n=2$ ) <sup>a</sup> EVM ( $n=5$ ) <sup>a</sup> MERRor ( $n=6$ ) <sup>a</sup> PERRor ( $n=7$ ) <sup>a</sup> SPOWer ( $n=9$ ) <sup>a</sup> CPOWer ( $n=10$ ) <sup>a</sup> ( $n=0$ ) <sup>a</sup> for I/Q points	yes
CHPower - channel power (Basic, cdmaOne, cdma2000, W-CDMA, 1xEV-DO modes)	SPECtrum ( $n=2$ ) <sup>a</sup> ( $n=0$ ) <sup>a</sup> for I/Q points	no markers
CSPur - spurs close (cdmaOne mode)	SPECtrum ( $n=2$ ) <sup>a</sup> ULIMit ( $n=3$ ) <sup>a</sup> ( $n=0$ ) <sup>a</sup> for I/Q points	yes
EEVM - EDGE error vector magnitude (EDGE mode)	EVMerror ( $n=2$ ) <sup>a</sup> MERRor ( $n=3$ ) <sup>a</sup> PERRor ( $n=4$ ) <sup>a</sup> ( $n=0$ ) <sup>a</sup> for I/Q points	yes
EORFspectr - EDGE output RF spectrum (EDGE mode)	RFEMod ( $n=2$ ) <sup>a</sup> RFESwitching ( $n=3$ ) <sup>a</sup> SPEMod ( $n=4$ ) <sup>a</sup> LIMMod ( $n=5$ ) <sup>a</sup> ( $n=0$ ) <sup>a</sup> for I/Q points	yes, only for a single offset  yes, only for multiple offsets

Measurement	Available Traces	Markers Available?
EPVTime - EDGE power versus time (EDGE mode)	RFENvelope ( $n=2$ ) <sup>a</sup> UMASk ( $n=3$ ) <sup>a</sup> LMASk ( $n=4$ ) <sup>a</sup> ( $n=0$ ) <sup>a</sup> for I/Q points	yes
ETSPur - EDGE transmit band spurs (EDGE mode)	SPECTrum ( $n=2$ ) <sup>a</sup> ULIMit ( $n=3$ ) <sup>a</sup> ( $n=0$ ) <sup>a</sup> for I/Q points	yes
EVM - error vector magnitude (NADC, PDC modes)	EVM ( $n=2$ ) <sup>a</sup> MERRor ( $n=3$ ) <sup>a</sup> PERRor ( $n=4$ ) <sup>a</sup> ( $n=0$ ) <sup>a</sup> for I/Q points	yes
EVMQpsk - QPSK error vector magnitude (cdma2000, W-CDMA, 1xEV-DO modes)	EVM ( $n=2$ ) <sup>a</sup> MERRor ( $n=3$ ) <sup>a</sup> PERRor ( $n=4$ ) <sup>a</sup> ( $n=0$ ) <sup>a</sup> for I/Q points	yes
IM - intermodulation (cdma2000, W-CDMA, 1xEV-DO modes)	SPECTrum ( $n=2$ ) <sup>a</sup> ( $n=0$ ) <sup>a</sup> for I/Q points	yes
MCPower - multi-carrier power (W-CDMA mode)	no traces ( $n=0$ ) <sup>a</sup> for I/Q points	no markers
OBW - occupied bandwidth (cdmaOne, cdma2000, PDC, W-CDMA, 1xEV-DO modes)	no traces ( $n=0$ ) <sup>a</sup> for I/Q points	no markers
ORFSpectrum - output RF spectrum (GSM, EDGE mode)	RFEMod ( $n=2$ ) <sup>a</sup> RFESwitching ( $n=3$ ) <sup>a</sup> SPEMod ( $n=4$ ) <sup>a</sup> LIMMod ( $n=5$ ) <sup>a</sup> ( $n=0$ ) <sup>a</sup> for I/Q points	yes, only for a single offset  yes, only for multiple offsets

Measurement	Available Traces	Markers Available?
PFErRor - phase and frequency error (GSM, EDGE mode)	PERRor ( $n=2$ ) <sup>a</sup> PFERror ( $n=3$ ) <sup>a</sup> RFENvelope ( $n=4$ ) <sup>a</sup> ( $n=0$ ) <sup>a</sup> for I/Q points	yes
PStAtistic - power statistics CCDF (Basic, cdma2000, W-CDMA, 1xEV-DO modes)	MEASured ( $n=2$ ) <sup>a</sup> GAUSSian ( $n=3$ ) <sup>a</sup> REFerence ( $n=4$ ) <sup>a</sup> ( $n=0$ ) <sup>a</sup> for I/Q points	yes
PVTime - power versus time (GSM, EDGE, 1xEV-DO, modes)	RFENvelope ( $n=2$ ) <sup>a</sup> UMASk ( $n=3$ ) <sup>a</sup> LMASk ( $n=4$ ) <sup>a</sup> ( $n=0$ ) <sup>a</sup> for I/Q points	yes
RHO - modulation quality (cdmaOne, cdma2000, W-CDMA, 1xEV-DO mode)	( $n=0$ ) <sup>a</sup> for I/Q points EVM ( $n=2$ ) <sup>a</sup> MERRor ( $n=3$ ) <sup>a</sup> PERRor ( $n=4$ ) <sup>a</sup> ( $n=0$ ) <sup>a</sup> for I/Q points	yes
SEMAsk - spectrum emissions mask (cdma2000, W-CDMA, 1xEV-DO mode)	SPECtrum ( $n=2$ ) <sup>a</sup> ( $n=0$ ) <sup>a</sup> for I/Q points	yes
TSPur - transmit band spurs (GSM, EDGE mode)	SPECtrum ( $n=2$ ) <sup>a</sup> ULIMit ( $n=3$ ) <sup>a</sup> ( $n=0$ ) <sup>a</sup> for I/Q points	yes
TXPower - transmit power (GSM, EDGE mode)	RFENvelope ( $n=2$ ) <sup>a</sup> IQ ( $n=8$ ) <sup>a</sup> ( $n=0$ ) <sup>a</sup> for I/Q points	yes

Measurement	Available Traces	Markers Available?
SPECTrum - (frequency domain) (all modes)	RFENvelope ( $n=2$ ) <sup>a</sup> for IQ ( $n=3$ ) <sup>a</sup> SPECTrum ( $n=4$ ) <sup>a</sup> ASPECTrum ( $n=7$ ) <sup>a</sup> ( $n=0$ ) <sup>a</sup> for I/Q points	yes
WAVEform - (time domain) (all modes)	RFENvelope ( $n=2$ ) <sup>a</sup> (also for Signal Envelope trace) IQ ( $n=5$ ) <sup>a</sup> ( $n=0$ ) <sup>a</sup> for I/Q points	yes

- a. The  $n$  number indicates the sub-opcode that corresponds to this trace. Detailed descriptions of the trace data can be found in the MEASure subsystem documentation by looking up the sub-opcode for the appropriate measurement.

### Marker X Value

**:CALCulate:<measurement>:MARKer [1] | 2 | 3 | 4:X <param>**

**:CALCulate:<measurement>:MARKer [1] | 2 | 3 | 4:X?**

Position the designated marker on its assigned trace at the specified X value. The parameter value is in X-axis units (which is often frequency or time).

The marker must have already been assigned to a trace. Use **:CALCulate:<measurement>:MARKer [1] | 2 | 3 | 4:TRACe** to assign a marker to a particular trace.

The query returns the current X value of the designated marker. The measurement must be completed before querying the marker.

Example: **CALC:SPEC:MARK2:X 1.2e6 Hz**

Range: For Phase Noise mode: Graph Start Offset and Stop Offset frequencies.

Default Unit: Matches the units of the trace on which the marker is positioned

Remarks: The keyword for the current measurement must be specified in the command. (Some examples include: LPLot, ACP, CFLocation, WAVEform)

Front Panel

Access: **Marker, <active marker>, RPG**

### Marker X Position

**:CALCulate:<measurement>:MARKer [1] | 2 | 3 | 4:X:POSition  
<integer>**

**:CALCulate:<measurement>:MARKer [1] | 2 | 3 | 4:X:POSition?**

Position the designated marker on its assigned trace at the specified X position. A trace is composed of a variable number of measurement points. This number changes depending on the current measurement conditions. The current number of points must be identified before using this command to place the marker at a specific location.

The marker must have already been assigned to a trace. Use **:CALCulate:<measurement>:MARKer [1] | 2 | 3 | 4:TRACe** to assign a marker to a particular trace.

The query returns the current X position for the designated marker. The measurement must be completed before querying the marker.

Example: **CALC:SPEC:MARK:X:POS 500**

Range: 0 to a maximum of (3 to 920,000)

Remarks: The keyword for the current measurement must be specified in the command. (Some examples include: SPECTrum, WAVeform)

Front Panel

Access: **Marker, <active marker>, RPG**

### Marker Readout Y Value

**:CALCulate:<measurement>:MARKer [1] | 2 | 3 | 4:Y?**

Readout the current Y value for the designated marker on its assigned trace. The value is in the Y-axis units for the trace (which is often dBm).

The marker must have already been assigned to a trace. Use **:CALCulate:<measurement>:MARKer [1] | 2 | 3 | 4:TRACe** to assign a marker to a particular trace.

The measurement must be completed before querying the marker.

Example: **CALC:SPEC:MARK1:Y?**

Default Unit: Matches the units of the trace on which the marker is positioned

Remarks: The keyword for the current measurement must be specified in the command. (Some examples include: LPLot, ACP, CFLocation, WAVeform)





---

## CALibration Subsystem

These commands control the self-alignment and self-diagnostic processes.

Numeric values for bit patterns can be entered using decimal or hexadecimal representations. (i.e. 0 to 32767 is equivalent to #H0 to #H7FFF) See the SCPI Basics information about using bit patterns for variable parameters.

### Wideband IF External Corrections

```
:CALibration:WBIF:ECORrection OFF|ON|0|1
```

```
:CALibration:WBIF:ECORrection?
```

For PSA Option 122 or 140. Turns on/off external corrections. Use the MMEMory file handling commands for external correction files. This functionality is used by the Option 235 External Calibration software.

Factory Preset: Off

Remarks: You must be in the Basic mode to use this command.  
Use INSTRument:SElect to set the mode.

History: Added with PSA revision A.06.00

### Wideband IF External Correction File Selection

```
:CALibration:WBIF:ECORrection:FILE <file name>
```

```
:CALibration:WBIF:ECORrection:FILE?
```

For PSA Option 122 or 140. Selects the file of external correction data that will be applied to the measurements. This functionality is used by the Option 235 External Calibration software.

Example: CAL:WBIF:ECOR:FILE 'A:\CORR022404.AMP'

Remarks: You must be in the Basic mode to use this command.  
Use INSTRument:SElect to set the mode.

History: Added with PSA revision A.06.00

## CONFigure Subsystem

The CONFigure commands are used with several other commands to control the measurement process. The full set of commands are described in the section “[MEASure Group of Commands](#)” on page 175.

Selecting measurements with the CONFigure/FETCh/MEASure/READ commands sets the instrument state to the defaults for that measurement and to make a single measurement. Other commands are available for each measurement to allow you to change: settings, view, limits, etc. Refer to:

```
SENSe:<measurement>, SENSe:CHANnel, SENSe:CORRection,
SENSe:DEFaults, SENSe:DEViation, SENSe:FREQuency,
SENSe:PACKet, SENSe:POWer, SENSe:RADio, SENSe:SYNC
CALCulate:<measurement>, CALCulate:CLIMits
DISPlay:<measurement>
TRIGger
```

The INITiate[:IMMEDIATE] or INITiate:REStart commands will initiate the taking of measurement data without resetting any of the measurement settings that you have changed from their defaults.

### Configure the Selected Measurement

```
:CONFigure:<measurement>
```

A CONFigure command must specify the desired measurement. It will set the instrument settings for that measurement’s standard defaults, but should not initiate the taking of data. The available measurements are described in the MEASure subsystem.

---

**NOTE**

If CONFigure initiates the taking of data, the data should be ignored. Other SCPI commands can be processed immediately after sending CONFigure. You do not need to wait for the CONF command to complete this 'false' data acquisition.

---

### Configure Query

```
:CONFigure?
```

The CONFigure query returns the name of the current measurement.

---

## DISPlay Subsystem

The DISPlay controls the selection and presentation of textual, graphical, and TRACe information. Within a DISPlay, information may be separated into individual WINDows.

### Power Statistics CCDF - X-Axis Scale/Div

`:DISPlay:CCDF:WINDow:TRACe:X[:SCALE]:PDIVision <rel_ampl>`

`:DISPlay:CCDF:WINDow:TRACe:X[:SCALE]:PDIVision?`

Allows you to enter a value (in dB) to change the horizontal scale.

Factory Preset: 2 dB per division

Range: 0.1 dB to 20 dB per division

Restrictions

and Notes: If the Scale Coupling default is On, this value is automatically determined by the measurement result. When you set a value manually, Scale Coupling automatically changes to Off.

History: Added for PSA revision A.09.00.

### Select Display Format

`:DISPlay:FORMat:TILE`

Selects the viewing format that displays multiple windows of the current measurement data simultaneously. Use `DISP:FORM:ZOOM` to return the display to a single window.

Remarks: You must be in the Basic, cdmaOne,cdma2000, 1xEV-DO, W-CDMA, GSM (w/EDGE), NADC, or PDC mode to use this command. Use `INSTRument:SElect` to set the mode

Front Panel

Access: **Zoom** (toggles between Tile and Zoom)

## Select Display Format

**:DISPlay:FORMat:ZOOM**

Selects the viewing format that displays only one window of the current measurement data (the current active window). Use DISP:FORM:TILE to return the display to multiple windows.

Remarks: You must be in the Basic, cdmaOne,cdma2000, 1xEV-DO, W-CDMA, GSM (w/EDGE), NADC, or PDC mode to use this command. Use INSTRument:SElect to set the mode

Front Panel

Access: **Zoom** (toggles between Tile and Zoom)

## Spectrum - Y-Axis Scale/Div

**:DISPlay:SPECTrum[n]:WINDow[m]:TRACe:Y[:SCALE]:PDIVision  
 <power>**

**:DISPlay:SPECTrum[n]:WINDow[m]:TRACe:Y[:SCALE]:PDIVision?**

Sets the amplitude reference level for the y-axis.

n – selects the view, the default is Spectrum.

m – selects the window within the view. The default is 1.

— n=1, m=1 Spectrum

— n=1, m=2 I/Q Waveform

— n=1, m=2 I and Q Waveform (Basic, W-CDMA, cdma2000)

— n=1, m=3 numeric data (Service mode, E4406A only)

— n=1, m=4 RF envelope (Service mode, E4406A only)

— n=2, m=1 I Waveform (Option B7C, E4406A only)

— n=2, m=2 Q Waveform (Option B7C, E4406A only)

— n=3, m=1 I/Q Polar (Basic, W-CDMA, cdma2000)

— n=4, m=1 Linear Spectrum (Basic, W-CDMA, cdma2000)

Factory Preset: 10 dB per division, for Spectrum

100 mV per division, for I/Q Waveform

Range: 0.1 dB to 20 dB per division, for Spectrum

1 nV to 20 V per division, for I/Q Waveform

Default Unit: 10 dB per division, for Spectrum

Remarks: May affect input attenuator setting.  
You must be in Basic, cdmaOne, cdma2000, 1xEV-DO, W-CDMA GSM w/EDGE, NADC, or PDC mode. Set the mode with INSTRument:SElect.

Front Panel  
Access: When in Spectrum measurement: **Amplitude Y Scale, Scale/Div.**

History: Added revision A.02.00

## Spectrum - Y-Axis Reference Level

```
:DISPlay:SPECTrum[n]:WINDow[m]:TRACe:Y[:SCALe]:RLEVel  
<power>
```

```
:DISPlay:SPECTrum[n]:WINDow[m]:TRACe:Y[:SCALe]:RLEVel?
```

Sets the amplitude reference level for the y-axis.

n, selects the view, the default is RF envelope.

- n=1, m=1 Spectrum
- n=1, m=2 I/Q Waveform
- n=1, m=2 I and Q Waveform (Basic, W-CDMA, cdma2000)
- n=1, m=3 numeric data (Service mode, E4406A only)
- n=1, m=4 RF envelope (Service mode, E4406A only)
- n=2, m=1 I Waveform (Option B7C, E4406A only)
- n=2, m=2 Q Waveform (Option B7C, E4406A only)
- n=3, m=1 I/Q Polar (Basic, W-CDMA, cdma2000)
- n=4, m=1 Linear Spectrum (Basic, W-CDMA, cdma2000)

m – selects the window within the view. The default is 1.

Factory Preset: 0 dBm, for Spectrum

Range: –250 to 250 dBm, for Spectrum

Default Unit: dBm, for Spectrum

Remarks: May affect input attenuator setting.  
For E4406A to use this command, the appropriate mode should be selected with INSTRument:SElect.  
You must be in Basic, cdmaOne, cdma2000, 1xEV-DO, W-CDMA GSM w/EDGE, NADC, or PDC mode. Set the mode with INSTRument:SElect.

Front Panel

Access: When in Spectrum measurement: **Amplitude Y Scale, Ref Level**

History: Added revision A.02.00

### Turn a Trace Display On/Off

`:DISPlay:TRACe [n] [:STATe] OFF|ON|0|1`

`:DISPlay:TRACe [n] [:STATe] ?`

Controls whether the specified trace is visible or not.

*n* is a sub-opcode that is valid for the current measurement. See the “MEASure Group of Commands” on page 175 for more information about sub-opcodes.

Factory Preset: On

Range: The valid traces and their sub-opcodes are dependent upon the selected measurement. See the following table.

The trace name assignment is independent of the window number.

Remarks: You must be in the Basic, cdmaOne,cdma2000, 1xEV-DO, W-CDMA, GSM (w/EDGE), NADC, or PDC mode to use this command. Use INSTRument:SElect to set the mode

Front Panel

Access: **Display, Display Traces**

Measurement	Available Traces	Markers Available?
ACP - adjacent channel power (Basic, cdmaOne, cdma2000, W-CDMA, iDEN (E4406A only), NADC, PDC modes)	no traces $(n=0)^a$ for I/Q points	no markers
BER - bit error rate (iDEN mode, E4406A only)	no traces $(n=0)^a$ for I/Q data	no markers
CDPower - code domain power (cdmaOne mode)	POWER $(n=2)^a$ TIMing $(n=3)^a$ PHASe $(n=4)^a$ $(n=0)^a$ for I/Q points	yes

Measurement	Available Traces	Markers Available?
CDPower - code domain power (cdma2000, 1xEV-DO, W-CDMA modes)	( $n=0$ ) <sup>a</sup> for I/Q raw data CDPower ( $n=2$ ) <sup>a</sup> EVM ( $n=5$ ) <sup>a</sup> MERRor ( $n=6$ ) <sup>a</sup> PERRor ( $n=7$ ) <sup>a</sup> SPOWer ( $n=9$ ) <sup>a</sup> CPOWer ( $n=10$ ) <sup>a</sup>	yes
CHPower - channel power (Basic, cdmaOne, cdma2000, 1xEV-DO, W-CDMA modes)	SPECtrum ( $n=2$ ) <sup>a</sup> ( $n=0$ ) <sup>a</sup> for I/Q raw data	no markers
CSPur - spurs close (cdmaOne mode)	SPECtrum ( $n=2$ ) <sup>a</sup> ULIMit ( $n=3$ ) <sup>a</sup> ( $n=0$ ) <sup>a</sup> for I/Q points	yes
EEVM - EDGE error vector magnitude (EDGE mode)	EVMerror ( $n=2$ ) <sup>a</sup> MERRor ( $n=3$ ) <sup>a</sup> PERRor ( $n=4$ ) <sup>a</sup> ( $n=0$ ) <sup>a</sup> for I/Q points	yes
EORFspectr - EDGE output RF spectrum (EDGE mode)	RFEMod ( $n=2$ ) <sup>a</sup> RFESwitching ( $n=3$ ) <sup>a</sup> SPEMod ( $n=4$ ) <sup>a</sup> LIMMod ( $n=5$ ) <sup>a</sup> ( $n=0$ ) <sup>a</sup> for I/Q points	yes, only for a single offset  yes, only for multiple offsets
EPVTime - EDGE power versus time (EDGE mode)	RFENvelope ( $n=2$ ) <sup>a</sup> UMASk ( $n=3$ ) <sup>a</sup> LMASk ( $n=4$ ) <sup>a</sup> ( $n=0$ ) <sup>a</sup> for I/Q points	yes



Measurement	Available Traces	Markers Available?
ETSPur - EDGE transmit band spurs (EDGE mode)	SPECTrum ( $n=2$ ) <sup>a</sup> ULIMit ( $n=3$ ) <sup>a</sup> ( $n=0$ ) <sup>a</sup> for I/Q points	yes
EVM - error vector magnitude (NADC, PDC modes)	EVM ( $n=2$ ) <sup>a</sup> MERRor ( $n=3$ ) <sup>a</sup> PERRor ( $n=4$ ) <sup>a</sup> ( $n=0$ ) <sup>a</sup> for I/Q points	yes
EVMQpsk - QPSK error vector magnitude (cdma2000, 1xEV-DO, W-CDMA modes)	EVM ( $n=2$ ) <sup>a</sup> MERRor ( $n=3$ ) <sup>a</sup> PERRor ( $n=4$ ) <sup>a</sup> ( $n=0$ ) <sup>a</sup> for I/Q raw data	yes
IM - intermodulation (cdma2000, 1xEV-DO, W-CDMA modes)	SPECTrum ( $n=2$ ) <sup>a</sup> ( $n=0$ ) <sup>a</sup> for I/Q raw data	yes
MCPower - multi-carrier power (W-CDMA mode)	no traces ( $n=0$ ) <sup>a</sup> for I/Q points	no markers
OBW - occupied bandwidth (cdmaOne, cdma2000, 1xEV-DO, iDEN (E4406A only), PDC, W-CDMA modes)	no traces ( $n=0$ ) <sup>a</sup> for I/Q raw data	no markers
ORFSpectrum - output RF spectrum (GSM, EDGE mode)	RFEMod ( $n=2$ ) <sup>a</sup> RFESwitching ( $n=3$ ) <sup>a</sup> SPEMod ( $n=4$ ) <sup>a</sup> LIMMod ( $n=5$ ) <sup>a</sup> ( $n=0$ ) <sup>a</sup> for I/Q points	yes, only for a single offset  yes, only for multiple offsets
PFERror - phase and frequency error (GSM, EDGE mode)	PERRor ( $n=2$ ) <sup>a</sup> PFERror ( $n=3$ ) <sup>a</sup> RFENvelope ( $n=4$ ) <sup>a</sup> ( $n=0$ ) <sup>a</sup> for I/Q points	yes

Measurement	Available Traces	Markers Available?
PSTatistic - power statistics CCDF (Basic, cdma2000, 1xEV-DO, W-CDMA modes)	MEASured ( $n=2$ ) <sup>a</sup> GAUSian ( $n=3$ ) <sup>a</sup> REFerence ( $n=4$ ) <sup>a</sup> ( $n=0$ ) <sup>a</sup> for I/Q points	yes
PVTime - power versus time (GSM, EDGE, 1xEV-DO, Service (E4406A only) modes)	( $n=0$ ) <sup>a</sup> for I/Q raw data RFENvelope ( $n=2$ ) <sup>a</sup> UMASk ( $n=3$ ) <sup>a</sup> LMASk ( $n=4$ ) <sup>a</sup>	yes
RHO - modulation quality (cdmaOne, cdma2000, W-CDMA mode)	( $n=0$ ) <sup>a</sup> for I/Q raw data EVM ( $n=2$ ) <sup>a</sup> MERRor ( $n=3$ ) <sup>a</sup> PERRor ( $n=4$ ) <sup>a</sup> ( $n=5$ ) <sup>a</sup> for I/Q corrected trace data	yes
RHO - modulation quality (1xEV-DO mode)	( $n=0$ ) <sup>a</sup> for I/Q raw data ( $n=1$ ) <sup>a</sup> for various summary results EVM ( $n=2$ ) <sup>a</sup> MERRor ( $n=3$ ) <sup>a</sup> PERRor ( $n=4$ ) <sup>a</sup> ( $n=5$ ) <sup>a</sup> for I/Q corrected trace data	yes
SEMask - spectrum emissions mask (cdma2000, 1xEV-DO, W-CDMA mode)	SPECtrum ( $n=2$ ) <sup>a</sup> ( $n=0$ ) <sup>a</sup> for I/Q raw data	yes
TSPur - transmit band spurs (GSM, EDGE mode)	SPECtrum ( $n=2$ ) <sup>a</sup> ULIMit ( $n=3$ ) <sup>a</sup> ( $n=0$ ) <sup>a</sup> for I/Q points	yes

Measurement	Available Traces	Markers Available?
TXPower - transmit power (GSM, EDGE mode)	RFENvelope ( $n=2$ ) <sup>a</sup> IQ ( $n=8$ ) <sup>a</sup> ( $n=0$ ) <sup>a</sup> for I/Q points	yes
SPECTrum - (frequency domain) (all modes)	RFENvelope ( $n=2$ ) <sup>a</sup> for Service mode (E4406A only) IQ ( $n=3$ ) <sup>a</sup> SPECTrum ( $n=4$ ) <sup>a</sup> ASPECTrum ( $n=7$ ) <sup>a</sup> ( $n=0$ ) <sup>a</sup> for I/Q raw data	yes
WAVEform - (time domain) (all modes)	RFENvelope ( $n=2$ ) <sup>a</sup> (also for Signal Envelope trace) IQ ( $n=5$ ) <sup>a</sup> ( $n=0$ ) <sup>a</sup> for I/Q raw data	yes

a. The  $n$  number indicates the sub-opcode that corresponds to this trace. Detailed descriptions of the trace data can be found in the MEASure subsystem documentation by looking up the sub-opcode for the appropriate measurement.

## Waveform - Y-Axis Scale/Div

```
:DISPlay:WAVEform [n] :WINDow [m] :TRACe:Y[:SCALE]:PDIVision
<power>
```

```
:DISPlay:WAVEform [n] :WINDow [m] :TRACe:Y[:SCALE]:PDIVision?
```

Sets the scale per division for the y-axis.

$n$ , selects the view, the default is RF envelope.

$n=1$ ,  $m=1$  RF envelope

$n=2$ ,  $m=1$  I/Q Waveform

$n=2$ ,  $m=1$  I and Q Waveform (Option B7C, E4406A only)

$n=4$ ,  $m=1$  I/Q Polar (Basic, W-CDMA, cdma2000)

$n=5$ ,  $m=1$  Linear Envelope (Option B7C, E4406A only)

m, selects the window within the view. The default is 1.

Factory Preset: 10 dBm, for RF envelope

Range: .1 dB to 20 dB, for RF envelope

Default Unit: dBm, for RF envelope

Remarks: May affect input attenuator setting.

You must be in Basic, cdmaOne, cdma2000, 1xEV-DO, W-CDMA GSM w/EDGE, NADC, or PDC mode. Set the mode with INSTRUMENT:SElect.

Front Panel

Access: When in Waveform measurement: **Amplitude Y Scale, Scale/Div.**

History: Added revision A.02.00

## Waveform - Y-Axis Reference Level

```
:DISPlay:WAVEform[n] :WINDow[m] :TRACe:Y[:SCALe] :RLEVel  
<power>
```

```
:DISPlay:WAVEform[n] :WINDow[m] :TRACe:Y[:SCALe] :RLEVel?
```

Sets the amplitude reference level for the y-axis.

n, selects the view, the default is RF envelope.

n=1, m=1 RF envelope

n=2, m=1 I/Q Waveform

n=2, m=1 I and Q Waveform (Option B7C, E4406A only)

n=4, m=1 I/Q Polar (Basic, W-CDMA, cdma2000)

n=5, m=1 Linear Envelope (Option B7C, E4406A only)

m, selects the window within the view. The default is 1.

Factory Preset: 0 dBm, for RF envelope

Range: -250 to 250 dBm, for RF envelope

Default Unit: dBm, for RF envelope

Remarks: May affect input attenuator setting.

You must be in Basic, cdmaOne, cdma2000, 1xEV-DO, W-CDMA GSM w/EDGE, NADC, or PDC mode. Set the mode with INSTRUMENT:SElect.

Front Panel Access: When in Waveform measurement:  
**Amplitude Y Scale, Ref Level**

History: Added revision A.02.00

---

## FETCh Subsystem

The FETCh? queries are used with several other commands to control the measurement process. These commands are described in the section on the “MEASure Group of Commands” on page 175. These commands apply only to measurements found in the MEASURE menu.

This command puts selected data from the most recent measurement into the output buffer (new data is initiated/measured). Use FETCh if you have already made a good measurement and you want to look at several types of data (different [n] values) from the single measurement. FETCh saves you the time of re-making the measurement. You can only fetch results from the measurement that is currently active.

If you need to make a new measurement, use the READ command, which is equivalent to an INITiate[:IMMEDIATE] followed by a FETCh.

:FETCh <meas>? will return valid data only when the measurement is in one of the following states:

- idle
- initiated
- paused

### Fetch the Current Measurement Results

**:FETCh:<measurement> [n] ?**

A FETCh? command must specify the desired measurement. It will return the valid results that are currently available, but will not initiate the taking of any new data. You can only fetch results from the measurement that is currently selected. The code number n selects the kind of results that will be returned. The available measurements and data results are described in the “MEASure Group of Commands” on page 175.

### Query Deep Capture Data (Remote Command Only)

**:FETCh:TCAPture?**

This query returns the contents of the wide bandwidth IF capture buffer. Prior to issuing this query, the capture buffer must be filled using the command :INIT:TCAP. If there is no valid data in the capture buffer, the command :FETCh:TCAP will return no data and the error “-230: Data corrupt or stale” will be placed in the error queue.

The query command (:FETC:TCAP) returns the following data:

```
<real>,<real>,<integer>,NORMAL|SWAPPED,<definite block  
length data>
```

The first returned parameter is the scale factor that must be applied to the returned data to convert the IQ samples to volts. The second parameter is the sample rate used to collect the data. The third parameter is the number of bytes in each IQ sample point pair. The size of each individual I or Q sample is half this number. The fourth parameter specifies the order of the I and Q samples in the data. If the parameter is NORMAL, the data is presented in IQ pairs. If the parameter is SWAPPED, the data is ordered as QI pairs. The final parameter is the capture buffer data. The data is formatted as a standard definite block length transfer. Each I or Q sample point is an integer value whose size is specified by the third parameter. Each point is in internal units and must be multiplied by the scale factor, given by the first parameter, in order to convert the data to volts. The sample points are always given in “most significant byte first” byte order. This command is unaffected by the :FORM:NORM command.

## FORMat Subsystem

The FORMat subsystem sets a data format for transferring numeric and array information. For PSA the TRACe[:DATA] command is affected by FORMat subsystem commands.

### Byte Order

**:FORMat:BORDER** NORMAl | SWAPped

**:FORMat:BORDER?**

Selects the binary data byte order for numeric data transfer. In normal mode the most significant byte is sent first. In swapped mode the least significant byte is first. (PCs use the swapped order.) Binary data byte order functionality does not apply to ASCII.

Factory Preset: Normal

Remarks: You must be in the Spectrum Analysis, Basic, cdma2000, 1xEV-DO, W-CDMA, GSM (w/EDGE), NADC, PDC, or Noise Figure mode to use this command. Use INSTRument:SElect to set the mode.

### Numeric Data Format

PSA/VSA: Basic, cdmaOne, cdma2000, 1xEV-DO, W-CDMA, GSM, EDGE, NADC, PDC modes:

**:FORMat[:DATA]** ASCii | REAL, 32 | REAL, 64

**:FORMat[:DATA]?**

PSA Spectrum Analysis mode only:

**:FORMat[:TRACe] [:DATA]**

ASCii | INTeger, 16 | INTeger, 32 | REAL, 32 | REAL, 64 | UINTEger, 16

**:FORMat[:TRACe] [:DATA]?**

**:FORMat[:TRACe] [:DATA]** ASCii | REAL[, 32]

**:FORMat[:TRACe] [:DATA]?**

This command controls the format of data input/output, that is, any data transfer across any remote port. The REAL and ASCII formats will format data in the current display units. The format of state data cannot be changed. It is always in a machine readable format only.

ASCII - Amplitude values are in ASCII, in amplitude units, separated by commas. ASCII format requires more memory than the binary formats. Therefore, handling large amounts of this type of data, will take more time and storage space.

Integer,16 - Binary 16-bit integer values in internal units (dBm), in a definite length block. \*\*PSA, SA mode only.

Integer,32 - Binary 32-bit integer values in internal units (dBm), in a definite length block.

Real,32 or Real,64 - Binary 32-bit (or 64-bit) real values in amplitude unit, in a definite length block. Transfers of real data are done in a binary block format.

A definite length block of data starts with an ASCII header that begins with # and indicates how many additional data points are following in the block. Suppose the header is #512320.

- The first digit in the header (5) tells you how many additional digits/bytes there are in the header.
- The 12320 means 12 thousand, 3 hundred, 20 data bytes follow the header.
- Divide this number of bytes by your selected data format bytes/point, either 8 (for real 64), or 4 (for real 32). In this example, if you are using real 64 then there are 1540 points in the block.

Example:       FORM REAL,64

Factory Preset: Real,32 for Spectrum Analysis mode

ASCII for Basic, cdmaOne, cdma2000, 1xEV-DO,  
W-CDMA, GSM with EDGE, NADC, PDC and Noise  
Figure modes

Remarks:       The acceptable settings for this command change for  
the different modes as described above.



## INITiate Subsystem

The INITiate subsystem is used to initiate a trigger for a sweep or measurement. “Measurement” refers to the functions found under the MEASURE front panel key or in the [“MEASure Group of Commands” on page 175](#). Refer also to the TRIGger and ABORt subsystems for related commands.

### Take New Data Acquisition for Selected Measurement

**:INITiate:<measurement>**

This command initiates a trigger cycle for the measurement specified, but does not return data. The valid measurement names are described in the MEASure subsystem.

If your selected measurement is not currently active, the instrument will change to the measurement in your INIT:<meas> command and initiate a trigger cycle.

This command is not available for the one-button measurements in the Spectrum Analysis mode.

Example:       INIT:ACP

### Continuous or Single Measurements

**:INITiate:CONTinuous OFF|ON|0|1**

**:INITiate:CONTinuous?**

Selects whether the trigger system is continuously initiated, or not.

This command affects the sweep in Spectrum Analysis mode, and affects measurement triggering when in a measurement. A “measurement” refers to any of the functions under the MEASURE key.

#### NOTE

This command operates in the same manner whether you are triggering a sweep cycle, or triggering a measurement cycle.

- When ON, at the completion of each sweep/measurement cycle the sweep/measurement system immediately initiates another sweep/measurement cycle.
- When OFF, the sweep/measurement system remains in the “idle” state until INITiate:CONTinuous is set to ON or an :INITiate[:IMMediate] command is received. On receiving the :INITiate[:IMMediate] command, a single sweep/measurement occurs followed by a return to the “idle” state.

- The query returns 1 or 0 into the output buffer. 1 is returned when there is continuous sweeping/measurement triggering. 0 is returned when there is single sweeping/measurement triggering.

Example:       INIT:CONT ON

Factory Preset: On (Off is usually recommended for remote operation.)

Front Panel

Access:       **Sweep** (Spectrum Analysis mode)  
              **Meas Control** (other measurement modes)  
              **Single**

## Take New Data Acquisitions

**:INITiate[:IMMediate]**

The command causes the system to exit the “idle” state and go to the “initiated” state. Once the trigger conditions are met, the sweep/measurement will start.

The instrument must be in the single sweep/measurement mode. The command is ignored if:

- INIT:CONT is ON
- a measurement is selected (any function under the MEASURE key), but it is not waiting in the “idle” state.

It then completes one full trigger cycle and returns to the “idle” state on completion of the sweep/measurement. (If you have selected averaging, or are in a measurement, it may average several sweeps/measurements. So there can be multiple data acquisitions, with multiple trigger events, for one full trigger cycle.)

Use the TRIGger[:SEQuence]:SOURce EXT command to select the external trigger source. If you are making a measurement (using a function from the MEASure subsystem), you may need to use a [:SENSE]:<meas>:TRIGger:SOURce command to select the desired trigger.

Use :FETCh:<meas>? to transfer a measurement result from memory to the output buffer. Refer to individual commands in the FETCh subsystem for more information.

While the system is in the “initiated” state, additional :INIT command(s) will restart the sweep/measurement. If averaging is on, the averaging will be reset.

Example:       INIT:IMM

Remarks:       See also the \*TRG command and the TRIGger subsystem.

Front Panel

Access:         **Single**  
**Meas Control, Restart**

## Restart the Measurement

**:INITiate:REStart**

This command applies to measurements found in the MEASURE menu. It restarts the current measurement from the “idle” state regardless of its current operating state. It is equivalent to:

INITiate[:IMMEDIATE]

ABORt (for continuous measurement mode)

Example:       INIT:REST

Front Panel

Access:         **Restart**  
  
or  
**Meas Control, Restart**

## Capture Time Data

**:INITiate:TCAPture**

Initiates the recording of data while in the Spectrum or Waveform measurements. You must have PSA Option 122 or 140 installed and have the wideband path selected SENSE:SPECTrum:IFPath WIDE or SENSE:WAVEform:IFPath WIDE.

Example:       INIT:TCAP

Remarks:       You must be in the Basic mode to use this command. Use INSTRument:SElect to set the mode.

History:        Added with PSA revision A.06.00

Front Panel

Access:         **Meas Control, Capture Setup, Capture**

---

## INSTrument Subsystem

This subsystem includes commands for querying and selecting instrument measurement (personality option) modes.

### Catalog Query

**:INSTrument:CATalog?**

Returns a comma separated list of strings which contains the names of all the installed applications. These names can only be used with the `INST:SELECT` command.

Example:        `INST:CAT?`

Query response: "CDMA,PNOISE"

### Select Application by Number

**:INSTrument:NSElect <integer>**

**:INSTrument:NSElect?**

Select the measurement mode by its instrument number. The actual available choices depends upon which applications are installed in the instrument.

- 1 = SA (PSA)
- 1 = SERVICE (E4406)
- 3 = GSM (E4406)
- 4 = CDMA (cdmaOne) (E4406/PSA)
- 5 = NADC (E4406/PSA)
- 6 = PDC (E4406/PSA)
- 8 = BASIC (E4406/PSA)
- 9 = WCDMA (W-CDMA with HSDPA/HSUPA) (E4406/PSA)
- 10 = CDMA2K (cdma2000 with 1xEV-DV) (E4406/PSA)
- 11 = IDEN (E4406)
- 12 = WIDEN (E4406)
- 13 = EDGE GSM (E4406/PSA)
- 14 = PNOISE (phase noise) (PSA)
- 15 = CMDA1XEV (1xEV-D0) (E4406/PSA)
- 18 = WLAN (PSA)
- 211 = TDSCDMA (PSA)
- 212 = TDDEMOD (PSA)
- 219 = NFIGURE (noise figure) (PSA)
- 231 = LINK (89600 VSA Link software)
- 233 = MRECEIVE (PSA)
- 239 = EMC (EMC Analyzer) (PSA)
- 241 = DMODULATION (PSA)

**NOTE**

If you are using the SCPI status registers and the analyzer mode is changed, the status bits should be read, and any errors resolved, prior to switching modes. Error conditions that exist prior to switching modes cannot be detected using the condition registers after the mode change. This is true unless they recur after the mode change, although transitions of these conditions can be detected using the event registers.

Changing modes resets all SCPI status registers and mask registers to their power-on defaults. Hence, any event or condition register masks must be re-established after a mode change. Also note that the power up status bit is set by any mode change, since that is the default state after power up.

Example:           INST:NSEL 4

Factory Preset: Persistent state with factory default of 1 (PSA/ESA)

Range:             1 to x, where x depends upon which applications are installed.

Front Panel

Access:            **MODE**

## Select Application

PSA Series:

```
:INSTRument [:SElect]  

SA | PNOISE | BASIC | CDMA | CDMA2K | EDGE GSM | NADC  

PDC | WCDMA | CDMA1XEV | NFIGURE | WLAN | MRECEIVE  

| TDSCDMA | TDDEMOD | EMC | DEMODIULATION
```

```
:INSTRument [:SElect] ?
```

Select the measurement mode. The actual available choices depend upon which modes (measurement applications) are installed in the instrument. A list of the valid choices is returned with the INST:CAT? query.

Once an instrument mode is selected, only the commands that are valid for that mode can be executed.

- 1 = SA (PSA)
- 1 = SERVICE (E4406)
- 3 = GSM (E4406)
- 4 = CDMA (cdmaOne) (E4406/PSA)
- 5 = NADC (E4406/PSA)
- 6 = PDC (E4406/PSA)
- 8 = BASIC (E4406/PSA)
- 9 = WCDMA (W-CDMA with HSDPA/HSUPA) (E4406/PSA)

- 10 = CDMA2K (cdma2000 with 1xEV-DV) (E4406/PSA)
- 11 = IDEN (E4406)
- 12 = WIDEN (E4406)
- 13 = EDGE GSM (E4406/PSA)
- 14 = PNOISE (phase noise) (PSA)
- 15 = CMDA1XEV (1xEV-D0) (E4406/PSA)
- 18 = WLAN (PSA)
- 211 = TDSCDMA (PSA)
- 212 = TDDEMOD (PSA)
- 219 = NFIGURE (noise figure) (PSA)
- 231 = LINK (89600 VSA Link software)
- 233 = MRECEIVE (PSA)
- 239 = EMC (EMC Analyzer) (PSA)
- 241 = DMODULATION (PSA)

---

**NOTE**

If you are using the status bits and the analyzer mode is changed, the status bits should be read, and any errors resolved, prior to switching modes. Error conditions that exist prior to switching modes cannot be detected using the condition registers after the mode change. This is true unless they recur after the mode change, although transitions of these conditions can be detected using the event registers.

Changing modes resets all SCPI status registers and mask registers to their power-on defaults. Hence, any event or condition register masks must be re-established after a mode change. Also note that the power up status bit is set by any mode change, since that is the default state after power up.

---

Example:       PSA Series instruments: INST:SEL CDMA

Factory Preset:  
                  Persistent state with factory default of Spectrum Analyzer mode

Front Panel  
Access:        **MODE**

## MEASure Group of Commands

This group includes the CONFIgure, FETCh, MEASure, and READ commands that are used to make measurements and return results. The different commands can be used to provide fine control of the overall measurement process, like changing measurement parameters from their default settings. Most measurements should be done in single measurement mode, rather than measuring continuously.

The SCPI default for the format of any data output is ASCII. The format can be changed to binary with FORMat:DATA which transports faster over the bus.

## Command Interactions: MEASure, CONFIgure, FETCh, INITiate and READ

Each one-button measurement has a group of commands that work together to make the measurement fast, but flexible.

**Figure 1** Measurement Group of Commands

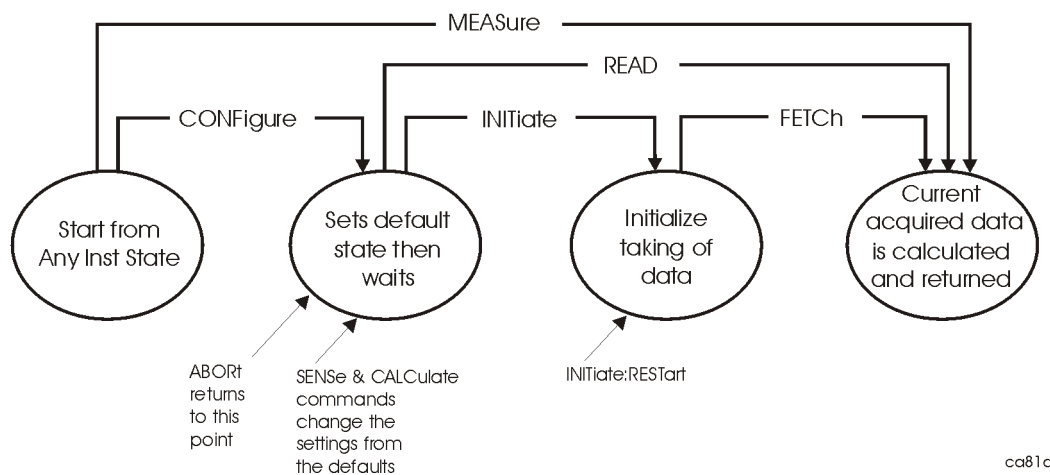

### Measure Commands:

**:MEASure:<measurement> [n] ?**

This is a fast single-command way to make a measurement using the factory default instrument settings. These are the settings and units that conform to the Mode Setup settings (e.g. radio standard) that you have currently selected.

- Stops the current measurement (if any) and sets up the instrument for the specified measurement using the factory defaults
- Initiates the data acquisition for the measurement
- Blocks other SCPI communication, waiting until the measurement is complete before returning results.
- If the function does averaging, it is turned on and the number of averages is set to 10.
- After the data is valid it returns the scalar results, or the trace data, for the specified measurement. The type of data returned may be defined by an [n] value that is sent with the command.

The scalar measurement results will be returned if the optional [n] value is not included, or is set to 1. If the [n] value is set to a value other than 1, the selected trace data results will be returned. See each command for details of what types of scalar results or trace data results are available.

ASCII is the default format for the data output. (Older versions of Spectrum Analysis and Phase Noise mode measurements only use ASCII.) The binary data formats should be used for handling large blocks of data since they are smaller and faster than the ASCII format. Refer to the FORMat:DATA command for more information.

If you need to change some of the measurement parameters from the factory default settings you can set up the measurement with the CONFigure command. Use the commands in the SENSE:<measurement> and CALCulate:<measurement> subsystems to change the settings. Then you can use the READ? command to initiate the measurement and query the results. See [Figure 1](#).

If you need to repeatedly make a given measurement with settings other than the factory defaults, you can use the commands in the SENSE:<measurement> and CALCulate:<measurement> subsystems to set up the measurement. Then use the READ? command to initiate the measurement and query results.

Measurement settings persist if you initiate a different measurement and then return to a previous one. Use READ:<measurement>? if you want to use those persistent settings. If you want to go back to the default settings, use MEASure:<measurement>?.



**Configure Commands:**

**:CONFigure:<measurement>**

This command stops the current measurement (if any) and sets up the instrument for the specified measurement using the factory default instrument settings. It sets the instrument to single measurement mode but should not initiate the taking of measurement data unless INIT:CONTinuous is ON. If you change any measurement settings after using the CONFigure command, the READ command can be used to initiate a measurement without changing the settings back to their defaults. In Spectrum Analysis mode the CONFigure command also turns the averaging function on and sets the number of averages to 10 for all measurements.

The CONFigure? query returns the current measurement name.

**Fetch Commands:**

**:FETCh:<measurement> [n] ?**

This command puts selected data from the most recent measurement into the output buffer. Use FETCh if you have already made a good measurement and you want to return several types of data (different [n] values, e.g. both scalars and trace data) from a single measurement. FETCh saves you the time of re-making the measurement. You can only FETCh results from the measurement that is currently active, it will not change to a different measurement.

If you need to get new measurement data, use the READ command, which is equivalent to an INITiate followed by a FETCh.

The scalar measurement results will be returned if the optional [n] value is not included, or is set to 1. If the [n] value is set to a value other than 1, the selected trace data results will be returned. See each command for details of what types of scalar results or trace data results are available. The binary data formats should be used for handling large blocks of data since they are smaller and transfer faster than the ASCII format. (FORMat:DATA)

FETCh may be used to return results other than those specified with the original READ or MEASure command that you sent.

**INITiate Commands:**

**:INITiate:<measurement>**

This command is not available for measurements in all the instrument modes:

- Initiates a trigger cycle for the specified measurement, but does not output any data. You must then use the FETCh<meas> command to return data. If a measurement other than the current one is specified, the instrument will switch to that measurement and then initiate it.  
 For example, suppose you have previously initiated the ACP measurement, but now you are running the channel power measurement. If you send INIT:ACP? it will change from channel power to ACP and will initiate an ACP measurement.
- Does not change any of the measurement settings. For example, if you have previously started the ACP measurement and you send INIT:ACP? it will initiate a new ACP measurement using the same instrument settings as the last time ACP was run.
- If your selected measurement is currently active (in the idle state) it triggers the measurement, assuming the trigger conditions are met. Then it completes one trigger cycle. Depending upon the measurement and the number of averages, there may be multiple data acquisitions, with multiple trigger events, for one full trigger cycle. It also holds off additional commands on GPIB until the acquisition is complete.

### READ Commands:

**:READ:<measurement> [n] ?**

- Does not preset the measurement to the factory default settings. For example, if you have previously initiated the ACP measurement and you send READ:ACP? it will initiate a new measurement using the same instrument settings.
- Initiates the measurement and puts valid data into the output buffer. If a measurement other than the current one is specified, the instrument will switch to that measurement before it initiates the measurement and returns results.

For example, suppose you have previously initiated the ACP measurement, but now you are running the channel power measurement. Then you send READ:ACP? It will change from channel power back to ACP and, using the previous ACP settings, will initiate the measurement and return results.

- Blocks other SCPI communication, waiting until the measurement is complete before returning the results

If the optional [n] value is not included, or is set to 1, the scalar measurement results will be returned. If the [n] value is set to a value other than 1, the selected trace data results will be returned. See each command for details of what types of scalar results or trace data results are available. The binary data formats should be used when handling large blocks of data since they are smaller and faster than the ASCII format. (FORMat:DATA)

## Current Measurement Query (Remote Command Only)

This command returns the name of the measurement that is currently running.

**Remote  
Command:**

:CONFigure?

Example:        CONF?

## Test Current Results Against all Limits (Remote Command Only)

Queries the status of the current measurement limit testing. It returns a 0 if the measured results pass when compared with the current limits. It returns a 1 if the measured results fail any limit tests.

**Remote  
Command:**

:CALCulate:CLIMits:FAIL?

Example:        CALC:CLIM:FAIL?

## Power Statistics CCDF Measurement

The general functionality of CONFigure, FETCh, MEASure, and READ are described at the beginning of this section. See the SENSE:PStat commands for more measurement related commands.

:CONFigure:CCDF

:INITiate:CCDF

:FETCh:CCDF [n] ?

:READ:CCDF [n] ?

:MEASure:CCDF [n] ?

Front Panel

Access: **Measure, Power Stat CCDF)**

### Measurement Results Available

n	Results Returned
0	Returns unprocessed I/Q trace data, as a series of trace point values, in volts. The I values are listed first in each pair, using the 0 through even-indexed values. The Q values are the odd-indexed values.
Not specified or 1	Returns 11 scalar results: <ol style="list-style-type: none"> <li>1. Average input power (in dBm)</li> <li>2. Probability at the average input level (in %)</li> <li>3. Power level that has 10% of the power</li> <li>4. Power level that has 1% of the power</li> <li>5. Power level that has 0.1% of the power</li> <li>6. Power level that has 0.01% of the power</li> <li>7. Power level that has 0.001% of the power</li> <li>8. Power level that has 0.0001% of the power</li> <li>9. Peak power relative to average (in dB)</li> <li>10. Peak power (in dBm)</li> <li>11. Count</li> </ol>

<b>n</b>	<b>Results Returned</b>
2	<p>Returns a series of 5001 floating the current measured power stat trace. This is the probability at particular power levels (average power) in the following order:</p> <ol style="list-style-type: none"> <li>1. Probability at 0.0 dB power</li> <li>2. Probability at 0.01 dB power</li> <li>3. Probability at 0.02 dB power</li> <li>...</li> <li>5000. Probability at 49.99 dB power</li> <li>5001. Probability at 50.00 dB power</li> </ol>
3	<p>Returns a series of 5001 floating point numbers (in %) that represent the Gaussian trace. This is the probability at particular power levels (average power) in the following order:</p> <ol style="list-style-type: none"> <li>1. Probability at 0.0 dB power</li> <li>2. Probability at 0.01 dB power</li> <li>3. Probability at 0.02 dB power</li> <li>...</li> <li>5000. Probability at 49.99 dB power</li> <li>5001. Probability at 50.00 dB power</li> </ol>
4	<p>Returns a series of 5001 floating point numbers (in %) that represent the user-definable reference trace. This is the probability at particular power levels (average power) in the following order:</p> <ol style="list-style-type: none"> <li>1. Probability at 0.0 dB power</li> <li>2. Probability at 0.01 dB power</li> <li>3. Probability at 0.02 dB power</li> <li>...</li> <li>5000. Probability at 49.99 dB power</li> <li>5001. Probability at 50.00 dB power</li> </ol>

## Spectrum (Frequency Domain) Measurement

This measures the amplitude of your input signal with respect to the frequency. It provides spectrum analysis capability using FFT (fast Fourier transform) measurement techniques. You must be in the Basic, cdmaOne, cdma2000, 1xEV-DO, W-CDMA, GSM (w/EDGE), NADC, or PDC mode to use these commands. Use INSTRument:SElect, to select the mode.

The general functionality of CONFigure, FETCh, MEASure, and READ are described at the beginning of this section. See the SENSE:SPECTrum commands for more measurement related commands.

```
:CONFigure:SPECTrum  
:INITiate:SPECTrum  
:FETCh:SPECTrum [n] ?  
:READ:SPECTrum [n] ?  
:MEASure:SPECTrum [n] ?
```

Front Panel

Access: **Measure, Spectrum (Freq Domain)**

After the measurement is selected, press **Restore Meas Defaults** to restore factory defaults.

### Measurement Results Available

n	Results Returned
0	Returns unprocessed I/Q trace data, as a series of trace point values, in volts. The I values are listed first in each pair, using the 0 and even-indexed values. The Q values are the odd-indexed values.

n	Results Returned
n=1 (or not specified)	<p>Returns the following scalar results:</p> <ol style="list-style-type: none"> <li>1. <b>FFT peak</b> is the FFT peak amplitude.</li> <li>2. <b>FFT frequency</b> is the FFT frequency of the peak amplitude.</li> <li>3. <b>FFT points</b> is the Number of points in the FFT spectrum.</li> <li>4. <b>First FFT frequency</b> is the frequency of the first FFT point of the spectrum.</li> <li>5. <b>FFT spacing</b> is the frequency spacing between the FFT points of the spectrum.</li> <li>6. <b>Time domain points</b> is the number of points in the time domain trace used for the FFT. The number of points doubles if the data is complex instead of real. See the time domain scaler description below.</li> <li>7. <b>First time point</b> is the time of the first time domain point, where time zero is the trigger event. (Also called, trigger error offset.)</li> <li>8. <b>Time spacing</b> is the time spacing between the time domain points. The time spacing value doubles if the data is complex instead of real. See the time domain scaler description below.</li> <li>9. <b>Time domain</b> returns a 1 if time domain is complex (I/Q) and complex data will be returned. It returns a 0 if the data is real. (raw ADC samples) When this value is 1 rather than 0 (complex vs. real data), the time domain points and the time spacing scalers both increase by a factor of two.</li> <li>10. <b>Scan time</b> is the total scan time of the time domain trace used for the FFT. The total scan time = (time spacing) X (time domain points – 1)</li> <li>11. <b>Current average count</b> is the current number of data measurements that have already been combined, in the averaging calculation.</li> </ol>
3	Returns the I and Q trace data. It is represented by I and Q pairs (in volts) versus time.
4	Returns spectrum trace data. That is, the trace of log-magnitude versus frequency. (The trace is computed using a FFT.)
6	Not used.
7	Returns the averaged spectrum trace data. That is, the trace of the averaged log-magnitude versus frequency.
8	Not used.
11, cdma2000, 1xEV-DO, W-CDMA, Basic modes only	Returns linear spectrum trace data values in Volts RMS.

<b>n</b>	<b>Results Returned</b>
12, cdma2000, 1xEV-DO, W-CDMA, Basic modes only	Returns averaged linear spectrum trace data values in Volts RMS.



## Waveform (Time Domain) Measurement

This measures the amplitude of your input signal with respect to time. It provides time domain analysis capability using FFT (fast Fourier transform) measurement techniques. You must be in the Basic, cdmaOne, cdma2000, 1xEV-DO, W-CDMA, GSM (w/EDGE), NADC, or PDC mode to use these commands. Use INSTRument:SElect, to select the mode.

The general functionality of CONFigure, FETCh, MEASure, and READ are described at the beginning of this section. See the SENSE:WAVEform commands for more measurement related commands.

```
:CONFigure:WAVEform
:INITiate:WAVEform
:FETCh:WAVEform [n] ?
:READ:WAVEform [n] ?
:MEASure:WAVEform [n] ?
```

Front Panel

Access: **Measure, Waveform (Time Domain)**

After the measurement is selected, press **Restore Meas Defaults** to restore factory defaults.

### Measurement Results Available

<b>n</b>	<b>Results Returned</b>
0 (see also 5)	Returns unprocessed I/Q trace data, as a series of trace point values, in volts. The I values are listed first in each pair, using the 0 through even-indexed values. The Q values are the odd-indexed values.

n	Results Returned
n=1 (or not specified)	<p>Returns the following scalar results:</p> <ol style="list-style-type: none"> <li>1. <b>Sample time</b> is a floating point number representing the time between samples when using the trace queries (n=0,2,etc).</li> <li>2. <b>Mean power</b> is the mean power (in dBm). This is either the power across the entire trace, or the power between markers if the markers are enabled. If averaging is on, the power is for the latest acquisition.</li> <li>3. <b>Mean power averaged</b> is the power (in dBm) for N averages, if averaging is on. This is either the power across the entire trace, or the power between markers if the markers are enabled. If averaging is on, the power is for the latest acquisition. If averaging is off, the value of the mean power averaged is the same as the value of the mean power.</li> <li>4. <b>Number of samples</b> is the number of data points in the captured signal. This number is useful when performing a query on the signal (i.e. when n=0,2,etc.).</li> <li>5. <b>Peak-to-mean ratio</b> has units of dB. This is the ratio of the maximum signal level to the mean power. Valid values are only obtained with averaging turned off. If averaging is on, the peak-to-mean ratio is calculated using the highest peak value, rather than the displayed average peak value.</li> <li>6. <b>Maximum value</b> is the maximum of the most recently acquired data (in dBm).</li> <li>7. <b>Minimum value</b> is the minimum of the most recently acquired data (in dBm).</li> </ol>
2	<p>Returns trace point values of the entire captured signal envelope trace data. These data points are floating point numbers representing the power of the signal (in dBm). There are N data points, where N is the <b>number of samples</b>. The period between the samples is defined by the <b>sample time</b>.</p>

## SENSE Subsystem

These commands are used to set the instrument state parameters so that you can measure a particular input signal. Some SENSE commands are only for use with specific measurements found under the MEASURE key menu or the [“MEASURE Group of Commands” on page 175](#). The measurement must be active before you can use these commands.

The SCPI default for the format of any data output is ASCII. The format can be changed to binary with FORMat:DATA which transports faster over the bus.

### Power Stat CCDF Measurement

Commands for querying the power statistics measurement results and for setting to the default values are found in the [“MEASURE Group of Commands” on page 175](#). The equivalent front panel keys for the parameters described in the following commands, are found under the **Meas Setup** key, after the Power Stat CCDF measurement has been selected from the **MEASURE** key menu.

#### Power Statistics CCDF—Reference Trace

```
[ :SENSE ] :CCDF:REFERENCE [ :STATe ] OFF | ON | 0 | 1
[ :SENSE ] :CCDF:REFERENCE [ :STATe ] ?
```

Allows you to toggle the reference trace display on or off.

Factory Preset: Off

State Saved Yes

History: Added in PSA revision A.09.00.

#### Power Statistics CCDF—Gaussian Line

```
[ :SENSE ] :CCDF:GAUSSian [ :STATe ] OFF | ON | 0 | 1
[ :SENSE ] :CCDF:GAUSSian [ :STATe ] ?
```

Allows you to toggle the Gaussian trace display on or off.

Factory Preset: On

State Saved Yes

History: Added in PSA revision A.09.00.

### Power Statistics CCDF—Channel Bandwidth

[ :SENSe ] :CCDF:BAWdwidth|BWIDth<freq>

[ :SENSe ] :CCDF:BAWdwidth|BWIDth?

Allows you to set the measurement bandwidth according to the channel bandwidth.

Factory Preset: 5 MHz

State Saved Yes

Min 10 kHz

Max Hardware dependent: Option 122 - 80.0000 MHz;  
Option 140 - 40.0000 MHz

Resolution 1 Hz

Coupling Meas BW = Sample Rate divided by 1.25

History: Added in PSA revision A.09.00.

### Power Statistics CCDF—Sweep Time

[ :SENSe ] :CCDF:SWEep:TIME<time>

[ :SENSe ] :CCDF:SWEep:TIME?

Sets the number of data points that will be used as the measurement interval.

Factory Preset: 1.0 ms

State Saved Yes

History: Added in PSA revision A.09.00.

### Power Statistics CCDF—Wideband IF Gain

[ :SENSe ] :CCDF:WBIF:IFGain<integer>

[ :SENSe ] :CCDF:WBIF:IFGain?

Sets the gain for the wideband IF path. Increasing the gain can increase the amplitude of small signals, as long as you don't overdrive the hardware. Wideband gain should usually be adjusted after setting the input attenuation.

Factory Preset: 0 dB

State Saved Yes

Range: -12 to +12 dB

Resolution 2 dB

History: Added in PSA revision A.09.00.

### Power Statistics CCDF—WBIF Filter Type

```
[ :SENSe ] :CCDF:WBIF:FILTer [ :TYPE ]
NONE | RCOSine | RRCosine | NYQuist | RNYQuist | GAUSSian
```

```
[ :SENSe ] :CCDF:WBIF:FILTer [ :TYPE ] ?
```

Sets the filter type/shape for the wideband IF filter.

NONE - Applies no filtering. Therefore it ignores the filter alpha and filter bandwidth settings.

RCOSine - raised cosine filter, where the filter alpha is set using SENSE:CCDF:WBIF:FILTer:ALPHA.

RRCosine - root raised cosine filter, where the filter alpha is set using SENSE:CCDF:WBIF:FILTer:ALPHA.

NYQuist - Nyquist filter shape.

RNYQuist - This root Nyquist filter has very abrupt cutoffs (that is, a very small filter alpha).

GAUSSian - Gaussian shape, where the filter bandwidth is set using SENSE:CCDF:WBIF:FILTer:BANDwidth|BWIDth. The filter alpha setting (SENSE:CCDF:WBIF:FILTer:ALPHA) is ignored with gaussian selected.

Factory Preset: NONE

State Saved Yes

History: Added in PSA revision A.09.00.

### Power Statistics CCDF—WBIF Filter Alpha

```
[ :SENSe ] :CCDF:WBIF:FILTer:ALPHA <value>
```

```
[ :SENSe ] :CCDF:WBIF:FILTer:ALPHA?
```

Specifies the Channel filter alpha for cosine and Nyquist filters applied within the wideband digital IF. This filter alpha is the ratio of transition bandwidth divided by 2, to filter bandwidth. The value is dimensionless.

Factory Preset: 0.3

State Saved Yes

Range: 0.01 to 1.00

Resolution 0.01

History: Added in PSA revision A.09.00.

### Power Statistics CCDF—WBIF Filter BW

```
[ :SENSe ] :CCDF:WBIF:FILTeR:BA NDwidth|BWIDth <value>
```

```
[ :SENSe ] :CCDF:WBIF:FILTeR:BA NDwidth|BWIDth?
```

Sets the bandwidth for the wideband IF filter. This specifies the bandwidth as a fraction of the sample rate.

Factory Preset: 0.5

Range: 0.01 to 1.00

Resolution 0.01

History: Added in PSA revision A.09.00.

### Power Statistics CCDF—Sample Rate

```
[ :SENSe ] :CCDF:SRATe <freq>
```

```
[ :SENSe ] :CCDF:SRATe?
```

Sets the sampling rate. This parameter is coupled with Meas BW. Changes to either Sample Rate or Meas BW will affect both parameters.

Factory Preset: 125.0 kHz

Range: 12.5 kHz to 100 MHz

Resolution: 0.0000001 Hz

Coupling: Sample Rate = Meas BW times 1.25

History: Added in PSA revision A.09.00.

### Power Statistics CCDF—Block Size

```
[ :SENSe ] :CCDF:BSIZe <integer>
```

```
[ :SENSe ] :CCDF:BSIZe?
```

Shows the number of samples within one Meas Interval.

Factory Preset: 2728

State Saved Yes

Range: 0 to 900000

Resolution: 1

Coupling:           Block Size = Sample Rate times Meas Interval + 1  
History:            Added in PSA revision A.09.00.

### Power Statistics CCDF—WBIF ADC Correction

`[ :SENSe ] :CCDF:WBIF:ADCCorrect OFF | ON | 0 | 1`

`[ :SENSe ] :CCDF:WBIF:ADCCorrect?`

Factory Preset: On

Saved State Yes

Couplings/

Dependencies This parameter is coupled with ADC Correction of other measurements.

History: Added in PSA revision A.09.00.

### Power Statistics CCDF—WBIF Flatness Correction

`[ :SENSe ] :CCDF:WBIF:FLATness OFF | ON | 0 | 1`

`[ :SENSe ] :CCDF:WBIF:FLATness?`

Turns IF flatness corrections on and off for the Option 122 or 140 wideband IF. The standard narrowband IF flatness control uses `SENSe:SPECTrum:BANDwidth | BWIDth:IF:FLATness`. This is an advanced control that normally does not need to be changed. And the setting is global, so it also affects the `WAVEform` measurement.

Factory Preset: ON

State Saved: Yes

Couplings/

Dependencies This parameter is coupled with WBIF Flatness of other measurements.

History: Added in PSA revision A.09.00.

### Power Statistics CCDF—WBIF ADC Dither

`[ :SENSe ] :CCDF:WBIF:ADC:DITHer OFF | ON | 0 | 1`

`[ :SENSe ] :CCDF:WBIF:ADC:DITHer?`

Turns the wideband dither signal on or off. The “ADC dither” refers to the introduction of noise to the digitized steps of the analog-to-digital converter; the result is an improvement in amplitude accuracy. Use of the ADC dither, however, reduces dynamic range by approximately 3 dB. It should only be turned off when measuring a noise-like signal and the 1 to 2 dB extra dynamic range is needed.

This control is independent of the narrowband ADC dither.

Factory Preset: On



State Saved: Yes  
History: Added in PSA revision A.09.00.

### Power Statistics CCDF—Trigger Interpolation

`[ :SENSE ] :CCDF:TRIGGER:INTERpolate OFF | ON | 0 | 1`

`[ :SENSE ] :CCDF:TRIGGER:INTERpolate?`

Turns the Trigger Interpolation function on or off.

Factory Preset: On

State Saved Yes

History Added in PSA revision A.09.00.

### Power Statistics CCDF—Trigger Source

`[ :SENSE ] :CCDF:TRIGGER:SOURCE`

`IMMEDIATE | IF | EXTERNAL [1] | EXTERNAL2 | FRAME | LINE |`

`[ :SENSE ] :CCDF:TRIGGER:SOURCE?`

Used to select the trigger source for the measurement.

Factory Preset: Free Run (Immediate)

State Saved Yes

History Added in PSA revision A.09.00.

### Power Statistics CCDF—Measurement Preset

`[ :SENSE ] :CCDF:RESTORE:DEFAULTS`

The Measurement Preset functionality restores all of the measurement parameters to their default values.

History Added in PSA revision A.09.00.

## Correction for RF Port External Attenuation

```
[[:SENSe]:CORRection[:RF]:LOSS <rel_power>
```

```
[[:SENSe]:CORRection[:RF]:LOSS?
```

Set the correction equal to the external attenuation used when measuring the device under test.

Factory Preset: 0 dB

Range: -50 to +50 dB

Default Unit: dB

Remarks: You must be in the Basic mode to use this command.  
Use INSTRument:SElect to set the mode.

Value is global to Basic mode.

Front Panel

Access: **Input, Ext Atten**

## Select the Input Signal

```
[[:SENSe]:FEED RF|AREFErence|IFALign|WBALign
```

```
[[:SENSe]:FEED?
```

Selects the input signal. The default input signal is taken from the front panel RF input port. For calibration and testing purposes the input signal can be taken from an internal 321.4 MHz IF alignment signal or an internal 50 MHz amplitude reference source.

RF selects the signal from the front panel RF INPUT port.

AREFErence selects the internal 50 MHz amplitude reference signal.

IFALign selects the internal, 321.4 MHz, IF alignment signal.

WBALign selects the internal IF alignment signal for the wide bandwidth hardware path.

(PSA with Option 122 or 140 in Basic mode)

Factory Preset: RF

Front Panel

Access: **Input, Input Port**

Remarks: You must be in the Basic, cdmaOne, cdma2000, 1xEV-DO, W-CDMA, GSM, EDGE, NADC, or PDC mode to use this command. Use INSTRument:SElect to set the mode.

History: PSA modified in version A.06.00.

## Select Live or Recorded Input Data

```
[ :SENSe ] :FEED:DATA INPut | RECOreded
```

```
[ :SENSe ] :FEED:DATA?
```

The wideband digitizer, Option 122 or 140, must be installed. When you select input while using recorded data, the command cancels the recording, deletes the data, and returns the instrument to measuring the selected input. The input selection is set using `SENSe:FEED:DATA`. (usually the RF input).

If you select recorded data when you were using the input, you must have valid recorded data available. Use `INITiate:TCAPture` to record data.

The query returns `INPut` or `RECOreded` to indicate whether the data currently being used is live from the designated input or is pre-recorded data from memory.

Factory Preset: Input

Remarks: You must be in the Basic mode to use this command.  
Use `INSTRument:SElect` to set the mode.

Front Panel

Access: **Input, Input Data**

History: Add to PSA with firmware rev A.06.00

## RF Power Commands

### RF Port Input Attenuation

```
[ :SENSe ] :POWER [ :RF ] :ATTenuation <rel_power>
```

```
[ :SENSe ] :POWER [ :RF ] :ATTenuation?
```

Set the RF input attenuator. This value is set at its auto value if RF input attenuation is set to auto.

Factory Preset: 0 dB

Range: 0 to 40 dB

Default Unit: dB

Front Panel

Access: **Input, Input Atten**

### RF Port Power Range Auto

```
[ :SENSe ] :POWER [ :RF ] :RANGe:AUTO OFF | ON | 0 | 1
```

`[ :SENSe ] :POWer [ :RF ] :RANGe :AUTO?`

Select the RF port power range to be set either automatically or manually.

ON - power range is automatically set as determined by the actual measured power level at the start of a measurement.

OFF - power range is manually set

Factory Preset: ON

Remarks: You must be in the cdmaOne, GSM, EDGE, NADC, PDC, cdma2000, W-CDMA, mode to use this command. Use INSTRument:SElect to set the mode.

Front Panel

Access: **Input, Max Total Pwr (at UUT)**

### RF Port Power Range Maximum Total Power

`[ :SENSe ] :POWer [ :RF ] :RANGe [ :UPPer ] <power>`

`[ :SENSe ] :POWer [ :RF ] :RANGe [ :UPPer ] ?`

Set the maximum expected total power level at the radio unit under test. This value is ignored if RF port power range is set to auto. External attenuation required above 30 dBm.

Factory Preset: -15.0 dBm

Range: -100.0 to 80.0 dBm for EDGE, GSM  
-100.0 to 27.7 dBm for cdmaOne  
-200.0 to 50.0 dBm for NADC, PDC  
-200.0 to 100.0 dBm for cdma2000, W-CDMA

Default Unit: dBm

Remarks: Global to the current mode. This is coupled to the RF input attenuation

You must be in the cdmaOne, GSM, EDGE, NADC, PDC, cdma2000, or W-CDMA mode to use this command. Use INSTRument:SElect to set the mode.

Front Panel

Access: **Input, Max Total Pwr (at UUT)**

## Spectrum (Frequency-Domain) Measurement

Commands for querying the spectrum measurement results and for setting to the default values are found in the “[MEASure Group of Commands](#)” on page 175. The equivalent front panel keys for the parameters described in the following commands, are found under the **Meas Setup** key, after the **Spectrum (Freq Domain)** measurement has been selected from the **MEASURE** key menu.

### Spectrum—Data Acquisition Packing

```
[ :SENSE ] :SPECTrum:ACQuisition:PACKing
AUTO | LONG | MEDium | SHORT
```

```
[ :SENSE ] :SPECTrum:ACQuisition:PACKing?
```

Select the amount of data acquisition packing. This is an advanced control that normally does not need to be changed.

Factory Preset: AUTO

Remarks: You must be in the Basic, Analog Modulation, cdmaOne, cdma2000, 1xEV-DO, W-CDMA, GSM, EDGE, NADC, or PDC mode to use this command. Use INSTRument:SElect to set the mode.

### Spectrum—ADC Dither Control

```
[ :SENSE ] :SPECTrum:ADC:DITHer [ :STATE ] AUTO | ON | OFF | 2 | 1 | 0
```

```
[ :SENSE ] :SPECTrum:ADC:DITHer [ :STATE ] ?
```

Turn the ADC dither on or off. This is an advanced control that normally does not need to be changed. The “ADC dither” refers to the introduction of noise to the digitized steps of the analog-to-digital converter; the result is an improvement in amplitude accuracy.

The wideband ADC dither (Option 122 or 140) uses  
SENSE:SPECTrum:WBIF:ADC:DITHer.

Factory Preset: AUTO

Remarks: You must be in the Basic, Analog Modulation, cdmaOne, cdma2000, 1xEV-DO, W-CDMA, GSM, EDGE, NADC, or PDC mode to use this command. Use INSTRument:SElect to set the mode.

## Spectrum—ADC Range

```
[ :SENSe] :SPECTrum:ADC:RANGe  
AUTO | APEak | APLock | NONE | P0 | P6 | P12 | P18
```

```
[ :SENSe] :SPECTrum:ADC:RANGe?
```

Select the range for the gain-ranging that is done in front of the ADC. This is an advanced control that normally does not need to be changed. Auto peak ranging is the default for this measurement. If you are measuring a CW signal please see the description below.

- **AUTO** - automatic range  

For FFT spectrums - auto ranging should not be not be used. An exception to this would be if you know that your signal is “bursty”. Then you might use auto to maximize the time domain dynamic range as long as you are not very interested in the FFT data.
- **Auto Peak (APEak)** - automatically peak the range  

For CW signals, the default of auto-peak ranging can be used, but a better FFT measurement of the signal can be made by selecting one of the manual ranges that are available: M6, P0 - P24. Auto peaking can cause the ADC range gain to move monotonically down during the data capture. This movement should have negligible effect on the FFT spectrum, but selecting a manual range removes this possibility. Note that if the CW signal being measured is close to the auto-ranging threshold, the noise floor may shift as much as 6 dB from sweep to sweep.
- **Auto Peak Lock (APLock)** - automatically peak lock the range  

For CW signals, auto-peak lock ranging may be used. It will find the best ADC measurement range for this particular signal and will not move the range as auto-peak can. Note that if the CW signal being measured is close to the auto-ranging threshold, the noise floor may shift as much as 6 dB from sweep to sweep. For “bursty” signals, auto-peak lock ranging should not be used. The measurement will fail to operate, since the wrong (locked) ADC range will be chosen often and overloads will occur in the ADC.
- **NONE** - turns off any auto-ranging without making any changes to the current setting.
- **M6** - (12-bit ADC E4406A) manually selects an ADC range that subtracts 6 dB of fixed gain across the range. Manual ranging is best for CW signals.
- **P0 to P18** - manually selects ADC ranges that add 0 to 18 dB of fixed gain across the range. Manual ranging is best for CW signals.
- **P0 to 24** - (12-bit ADC E4406A) manually selects ADC ranges that

add 0 to 24 dB of fixed gain across the range. Manual ranging is best for CW signals.

Factory Preset: APEak

Remarks: You must be in the Basic, Analog Modulation, cdmaOne, cdma2000, 1xEV-DO, W-CDMA, GSM, EDGE, NADC, or PDC mode to use this command. Use INSTRument:SElect to set the mode.

### Spectrum—Automatic Analog Anti-alias Filter

```
[ :SENSe ] :SPECTrum:AFILter:AUTO OFF|ON|0|1
```

```
[ :SENSe ] :SPECTrum:AFILter:AUTO?
```

For Option 122 or 140 only. Sets the anti-alias filter selection to be done automatically or manually for measurements using the wideband IF path. It should be left on for calibrated measurements. When on, it uses the 80 MHz filter (Opt 122) or the 40 MHz filter (Opt 140) for measurements with bandwidths greater than 36 MHz. Otherwise it uses the 36 MHz filter.

Factory Preset: On

Remarks: You must be in the Basic mode to use this command. Use INSTRument:SElect to set the mode.

History: Added in PSA revision A.06.00.

### Spectrum—Average Clear

```
[ :SENSe ] :SPECTrum:AVERAge:CLEar
```

The average data is cleared and the average counter is reset.

Remarks: You must be in the Basic, Analog Modulation, cdmaOne, cdma2000, 1xEV-DO, W-CDMA, GSM, EDGE, NADC, or PDC mode to use this command. Use INSTRument:SElect to set the mode.

### Spectrum—Number of Averages

```
[ :SENSe ] :SPECTrum:AVERAge:COUNT <integer>
```

```
[ :SENSe ] :SPECTrum:AVERAge:COUNT?
```

Set the number of 'sweeps' that will be averaged. After the specified number of 'sweeps' (average counts), the averaging mode (terminal control) setting determines the averaging action.

Factory Preset: 25

Range: 1 to 10,000



Remarks: You must be in the Basic, Analog Modulation, cdmaOne, cdma2000, 1xEV-DO, W-CDMA, GSM, EDGE, NADC, or PDC mode to use this command. Use INSTRUMENT:SElect to set the mode.

### Spectrum—Averaging State

```
[ :SENSE ] :SPECTrum:AVERage [ :STATe ] OFF | ON | 0 | 1
```

```
[ :SENSE ] :SPECTrum:AVERage [ :STATe ] ?
```

Turn averaging on or off.

Factory Preset: On

Remarks: You must be in the Basic, Analog Modulation, cdmaOne, cdma2000, 1xEV-DO, W-CDMA, GSM, EDGE, NADC, or PDC mode to use this command. Use INSTRUMENT:SElect to set the mode.

### Spectrum—Number of Time Averages

```
[ :SENSE ] :SPECTrum:AVERage:TACount <integer>
```

```
[ :SENSE ] :SPECTrum:AVERage:TACount ?
```

Set the number of time averages to be made when using the Option 122 or 140 wideband hardware. This averaging is much faster than the standard averaging. It is done before any measurement application averaging is done.

Factory Preset: 1

Range: 1 to 524288

Couplings/

Dependencies: To use this hardware averaging:

- The trigger source must be Frame.
- The signal should be a repetitive (periodic) signal.
- The number of samples in the measurement acquisition must be < 16384.

Remarks: You must be in the Basic mode to use this command. Use INSTRUMENT:SElect to set the mode.

History: Added for PSA revision A.06.00.

## Spectrum—Averaging Termination Control

```
[ :SENSe ] :SPECTrum:AVERAge:TCONTRol EXPONential | REPeat  
[ :SENSe ] :SPECTrum:AVERAge:TCONTRol?
```

Select the type of termination control used for the averaging function. This determines the averaging action after the specified number of ‘sweeps’ (average count) is reached.

EXPONential - Each successive data acquisition after the average count is reached, is exponentially weighted and combined with the existing average.

REPeat - After reaching the average count, the averaging is reset and a new average is started.

Factory Preset: EXPONential

Remarks: You must be in the Basic, Analog Modulation, cdmaOne, cdma2000, 1xEV-DO, W-CDMA, GSM, EDGE, NADC, or PDC mode to use this command. Use INSTRUMENT:SELEct to set the mode.

## Spectrum—Averaging Type

```
[ :SENSe ] :SPECTrum:AVERAge:TYPE  
LOG | MAXimum | MINimum | RMS | SCALar  
[ :SENSe ] :SPECTrum:AVERAge:TYPE?
```

Select the type of averaging.

LOG – The log of the power is averaged. (This is also known as video averaging.)

MAXimum – The maximum values are retained.

MINimum – The minimum values are retained.

RMS – The power is averaged, providing the rms of the voltage.

SCALar – The voltage is averaged.

Factory Preset: LOG

Remarks: You must be in the Basic, Analog Modulation, cdmaOne, cdma2000, 1xEV-DO, W-CDMA, GSM, EDGE, NADC, or PDC mode to use this command. Use INSTRUMENT:SELEct to set the mode.

### Spectrum—Select Pre-FFT Bandwidth

```
[ :SENSE ] :SPECTrum: BANDwidth | BWIDth: IF: AUTO OFF | ON | 0 | 1
```

```
[ :SENSE ] :SPECTrum: BANDwidth | BWIDth: IF: AUTO?
```

Select auto or manual control of the pre-FFT BW.

Factory Preset: Auto, 1.55 MHz

Auto, 10 MHz for wideband IF path  
(SENSE:SPECTrum:IFPath WIDE)

Couplings/

Dependencies: If you have a wideband option (122 or 140) and the wideband IF path is selected, then the sample rate =  $1.25 \times$  IF bandwidth.

Remarks: You must be in the Basic, Analog Modulation, cdmaOne, cdma2000, 1xEV-DO, W-CDMA, GSM, EDGE, NADC, or PDC mode to use this command. Use INSTRument:SElect to set the mode.

Front Panel

Access: **Measure, Spectrum, Meas Setup, More, Advanced, Pre-FFT BW.**

History: Modified in PSA revision A.06.00.

### Spectrum—IF Flatness Corrections

```
[ :SENSE ] :SPECTrum: BANDwidth | BWIDth: IF: FLATness OFF | ON | 0 | 1
```

```
[ :SENSE ] :SPECTrum: BANDwidth | BWIDth: IF: FLATness?
```

Turns IF flatness corrections on and off for the pre-FFT narrowband IF. The wideband IF flatness control for Options 122 and 140 uses SENSE:SPECTrum:WBIF:FLATness.

Factory Preset: ON

Remarks: You must be in the Basic, Analog Modulation, cdmaOne, cdma2000, 1xEV-DO, W-CDMA, GSM, EDGE, NADC, or PDC mode to use this command. Use INSTRument:SElect to set the mode.

Front Panel

Access: **Measure, Spectrum, Meas Setup, More, Advanced, Pre-FFT BW**

### Spectrum—Pre-ADC Bandpass Filter

```
[ :SENSe ] :SPECTrum: BANDwidth | BWIDth: PADC OFF | ON | 0 | 1  
[ :SENSe ] :SPECTrum: BANDwidth | BWIDth: PADC ?
```

### Spectrum—Pre-FFT BW

```
[ :SENSe ] :SPECTrum: BANDwidth | BWIDth: PFFT [ :SIZE ] <freq>  
[ :SENSe ] :SPECTrum: BANDwidth | BWIDth: PFFT [ :SIZE ] ?
```

Set the pre-FFT bandwidth. This is an advanced control that normally does not need to be changed.

Frequency span, resolution bandwidth, and the pre-FFT bandwidth settings are normally coupled. If you are not auto-coupled, there can be combinations of these settings that are not valid.

Factory Preset: 1.55 MHz

1.25 MHz for cdmaOne

Range: 1 Hz to 10.0 MHz

Remarks: You must be in the Basic, Analog Modulation, cdmaOne, cdma2000, 1xEV-DO, W-CDMA, GSM, EDGE, NADC, or PDC mode to use this command. Use INSTRument:SELEct to set the mode.

### Spectrum—Pre-FFT BW Filter Type

```
[ :SENSe ] :SPECTrum: BANDwidth | BWIDth: PFFT: TYPE FLAT | GAUSSian  
[ :SENSe ] :SPECTrum: BANDwidth | BWIDth: PFFT: TYPE ?
```

Select the type of pre-FFT filter that is used. This is an advanced control that normally does not need to be changed.

Flat top (FLAT)- a filter with a flat amplitude response, which provides the best amplitude accuracy.

GAUSSian - a filter with Gaussian characteristics, which provides the best pulse response.

Factory Preset: FLAT

Couplings/

Dependencies: From the front panel this functionality is not available (key is greyed out), but this command will change the setting.

Remarks: You must be in the Basic, Analog Modulation, cdmaOne, cdma2000, 1xEV-DO, W-CDMA, GSM, EDGE, NADC, or PDC mode to use this command. Use INSTRUMENT:SELEct to set the mode.

History: PSA: modified with revision A.06.00

### Spectrum—Resolution BW

```
[ :SENSE ] :SPECTrum: BANDwidth | BWIDth [ :RESolution ] <freq>
```

```
[ :SENSE ] :SPECTrum: BANDwidth | BWIDth [ :RESolution ] ?
```

Set the resolution bandwidth for the FFT. This is the bandwidth used for resolving the FFT measurement. It is not the pre-FFT bandwidth. This value is ignored if the function is auto-coupled.

Frequency span, resolution bandwidth, and the pre-FFT bandwidth settings are normally coupled. If you are not auto-coupled, there can be combinations of these settings that are not valid.

Factory Preset: 20.0 kHz

Range: 0.10 Hz to 3.0 MHz

Remarks: You must be in the Basic, Analog Modulation, cdmaOne, cdma2000, 1xEV-DO, W-CDMA, GSM, EDGE, NADC, or PDC mode to use this command. Use INSTRUMENT:SELEct to set the mode.

### Spectrum—Resolution BW Auto

```
[ :SENSE ] :SPECTrum: BANDwidth | BWIDth [ :RESolution ] :AUTO  
OFF | ON | 0 | 1
```

```
[ :SENSE ] :SPECTrum: BANDwidth | BWIDth [ :RESolution ] :AUTO?
```

Select auto or manual control of the resolution BW. The automatic mode couples the resolution bandwidth setting to the frequency span.

Factory Preset: ON

Remarks: You must be in the Basic, Analog Modulation, cdmaOne, cdma2000, W-CDMA, GSM, EDGE, NADC, or PDC mode to use this command. Use INSTRUMENT:SELEct to set the mode.

## Spectrum—Decimation of Spectrum Display

```
[ :SENSe ] :SPECTrum:DECimate [ :FACTor ] <integer>
```

```
[ :SENSe ] :SPECTrum:DECimate [ :FACTor ] ?
```

Sets the amount of data decimation done by the hardware and/or the software. Decimation by *n* keeps every *n*th sample, throwing away each of the remaining samples in the group of *n*. For example, decimation by 3 keeps every third sample, throwing away the two in between. Similarly, decimation by 5 keeps every fifth sample, throwing away the four in between.

Using zero (0) decimation selects the automatic mode. The measurement will then automatically choose decimation by “1” or “2” as is appropriate for the bandwidth being used.

This is an advanced control that normally does not need to be changed.

Factory Preset: 0

Range: 0 to 1,000, where 0 sets the function to automatic

Remarks: You must be in the Basic, Analog Modulation, cdmaOne, cdma2000, 1xEV-DO, W-CDMA, GSM, EDGE, NADC, or PDC mode to use this command. Use INSTRument:SElect to set the mode.

## Spectrum—FFT Length

```
[ :SENSe ] :SPECTrum:FFT:LENGth <integer>
```

```
[ :SENSe ] :SPECTrum:FFT:LENGth?
```

Set the FFT length. This value is only used if length control is set to manual. The value must be greater than or equal to the window length value. Any amount greater than the window length is implemented by zero-padding. This is an advanced control that normally does not need to be changed.

Factory Preset: 1024

Range: min, depends on the current setting of the spectrum window length

max, 1,048,576

Remarks: You must be in the Basic, Analog Modulation, cdmaOne, cdma2000, 1xEV-DO, W-CDMA, GSM, EDGE, NADC, or PDC mode to use this command. Use INSTRument:SElect to set the mode.

### Spectrum—FFT Length Auto

```
[ :SENSE ] :SPECTrum:FFT:LENGth:AUTO OFF | ON | 0 | 1
```

```
[ :SENSE ] :SPECTrum:FFT:LENGth:AUTO?
```

Select auto or manual control of the FFT and window lengths.

This is an advanced control that normally does not need to be changed.

On - the window lengths are coupled to resolution bandwidth, window type (FFT), pre-FFT bandwidth (sample rate) and SENSE:SPECTrum:FFT:RBWPoints.

Off - lets you set SENSE:SPECTrum:FFT:LENGth and SENSE:SPECTrum:FFT:WINDow:LENGth.

Factory Preset: ON

Remarks: You must be in the Basic, Analog Modulation, cdmaOne, cdma2000, 1xEV-DO, W-CDMA, GSM, EDGE, NADC, or PDC mode to use this command. Use INSTRument:SElect to set the mode.

### Spectrum—FFT Minimum Points in Resolution BW

```
[ :SENSE ] :SPECTrum:FFT:RBWPoints <real>
```

```
[ :SENSE ] :SPECTrum:FFT:RBWPoints?
```

Set the minimum number of data points that will be used inside the resolution bandwidth. The value is ignored if length control is set to manual. This is an advanced control that normally does not need to be changed.

Factory Preset: 1.30

Range: 0.1 to 100

Remarks: You must be in the Basic, Analog Modulation, cdmaOne, cdma2000, 1xEV-DO, W-CDMA, GSM, EDGE, NADC, or PDC mode to use this command. Use INSTRument:SElect to set the mode.

### Spectrum—FFT Window Delay

```
[ :SENSe ] :SPEctrum:FFT:WINDow:DELay <real>
```

```
[ :SENSe ] :SPEctrum:FFT:WINDow:DELay?
```

Set the FFT window delay to move the FFT window from its nominal position of being centered within the time capture. This function is not available from the front panel. It is an advanced control that normally does not need to be changed.

Factory Preset: 0

Range: -10.0 to +10.0s

Default Unit: seconds

Remarks: You must be in the Basic, Analog Modulation, cdmaOne, cdma2000, 1xEV-DO, W-CDMA, GSM, EDGE, NADC, or PDC mode to use this command. Use INSTRument:SElect to set the mode.

### Spectrum—FFT Window Length

```
[ :SENSe ] :SPEctrum:FFT:WINDow:LENGth <integer>
```

```
[ :SENSe ] :SPEctrum:FFT:WINDow:LENGth?
```

Set the FFT window length. This value is only used if length control is set to manual. This is an advanced control that normally does not need to be changed.

Factory Preset: 706

566 for Basic, WLAN, and Flexible Digital Modulation Analysis modes in PSA Series

Range: 8 to 1,048,576

Remarks: You must be in the Basic, Analog Modulation, cdmaOne, cdma2000, 1xEV-DO, W-CDMA, GSM, EDGE, NADC, or PDC mode to use this command. Use INSTRument:SElect to set the mode.

### Spectrum—FFT Window

```
[ :SENSe ] :SPEctrum:FFT:WINDow [ :TYPE ]
```

```
BH4Tap | BLACkman | FLATtop | GAUSSian | HAMMING | HANNing | KB70 | KB90 |  
KB110 | UNIFORM
```

```
[ :SENSe ] :SPEctrum:FFT:WINDow [ :TYPE ] ?
```

Select the FFT window type.



BH4Tap - Blackman Harris with 4 taps

BLACkman - Blackman

FLATtop - flat top, the default (for high amplitude accuracy)

GAUSSian - Gaussian with alpha of 3.5

HAMMing - Hamming

HANNing - Hanning

KB70, 90, and 110 - Kaiser Bessel with sidelobes at -70, -90, or -110 dBc

UNIFORM - no window is used. (This is the unity response.)

Factory Preset: FLATtop

Remarks: This selection affects the acquisition point quantity and the FFT size, based on the resolution bandwidth selected.

You must be in the Basic, Analog Modulation, cdmaOne, cdma2000, 1xEV-DO, W-CDMA, GSM, EDGE, NADC, or PDC mode to use this command. Use INSTRUMENT:SElect to set the mode.

## Spectrum—Frequency Span

[ :SENSE ] :SPECTrum:FREQUency:SPAN <freq>

[ :SENSE ] :SPECTrum:FREQUency:SPAN?

Set the frequency span to be measured.

Factory Preset: 1.0 MHz

10.0 MHz for Basic, WLAN and Flexible Digital Modulation Analysis modes in PSA Series

Range: 10 Hz to 10.0 MHz (15 MHz when Service mode is selected)

Default Unit: Hz

Remarks: The actual measured span will generally be slightly wider due to the finite resolution of the FFT.

You must be in the Basic, Analog Modulation, cdmaOne, cdma2000, 1xEV-DO, W-CDMA, GSM, EDGE, NADC, or PDC mode to use this command. Use INSTRUMENT:SElect to set the mode.

### Spectrum—Wideband IF Path Gain Selection

```
[ :SENSe ] :SPECTrum:IFGain <numeric>
```

```
[ :SENSe ] :SPECTrum:IFGain?
```

Sets the gain for the wideband IF path. You must have PSA Option 122 or 140 to use this command and you must have selected SENSE:SPECTrum:IFPath WIDE. Increasing the gain will improve sensitivity. Increasing the gain increases the amplitude of small signals but you must be careful not to overdrive the analyzer.

Factory Preset: 0 dB

Range: -12 to +12 dB

Remarks: You must be in the Basic mode to use this command.  
Use INSTRument:SElect to set the mode.

History: Added for PSA revision A.06.00.

### Spectrum—Wideband IF Path Selection

```
[ :SENSe ] :SPECTrum:IFPath NARRow|WIDE
```

```
[ :SENSe ] :SPECTrum:IFPath?
```

You must have Option 122 or 140 for this command. It selects either the wideband input hardware or the standard “narrowband” path.

Factory Preset: Narrow

Couplings/

Dependencies: Narrow is not available unless Option B7J is available.  
Narrow is not available for frequencies >3 GHz.

Remarks: You must be in the Basic mode to use this command.  
Use INSTRument:SElect to set the mode.

History: Added for PSA revision A.06.00.

### Spectrum—Sweep (Acquisition) Time

```
[ :SENSe ] :SPECTrum:SWEep:TIME [:VALue] <time>
```

```
[ :SENSe ] :SPECTrum:SWEep:TIME?
```

Set the sweep (measurement acquisition) time. It is used to specify the length of the time capture record. If the value you specify is less than the capture time required for the specified span and resolution bandwidth, the value is ignored. The value is set at its auto value when auto is selected. This is an advanced control that normally does not need to be changed.

Factory Preset: 18.83  $\mu$ s  
 Range: 100 ns to 10 s  
 Default Unit: seconds  
 Remarks: You must be in the Basic, Analog Modulation, cdmaOne, cdma2000, 1xEV-DO, W-CDMA, GSM, EDGE, NADC, or PDC mode to use this command. Use INSTRUMENT:SElect to set the mode.

### Spectrum—Sweep (Acquisition) Time Auto

```
[ :SENSE ] :SPECTrum:SWEep:TIME:AUTO OFF | ON | 0 | 1  

[ :SENSE ] :SPECTrum:SWEep:TIME:AUTO
```

Select auto or manual control of the sweep (acquisition) time. This is an advanced control that normally does not need to be changed.

AUTO - couples the Sweep Time to the Frequency Span and Resolution BW

Manual - the Sweep Time is uncoupled from the Frequency Span and Resolution BW.

Factory Preset: AUTO

Remarks: You must be in the Basic, Analog Modulation, cdmaOne, cdma2000, 1xEV-DO, W-CDMA, GSM, EDGE, NADC, or PDC mode to use this command. Use INSTRUMENT:SElect to set the mode.

### Spectrum—Trigger Source

```
[ :SENSE ] :SPECTrum:TRIGger:SOURce  

EXTernal [1] | EXTernal2 | FRAMe | IF | LINE | IMMEDIATE | RFBURSt  

[ :SENSE ] :SPECTrum:TRIGger:SOURce?
```

Select the trigger source used to control the data acquisitions.

EXTernal1 - front panel external trigger input

EXTernal2 - rear panel external trigger input

FRAMe - internal frame timer from front panel input

IF - internal IF envelope (video) trigger

LINE - internal line trigger

IMMEDIATE - the next data acquisition is immediately taken (also called free run)

RFBurst - wideband RF burst envelope trigger that has automatic level control for periodic burst signals

Factory Preset: IMMEDIATE (free run)

RFBurst, for GSM mode

Remarks: You must be in the Basic, Analog Modulation, cdmaOne, cdma2000, 1xEV-DO, W-CDMA, GSM, EDGE, NADC, or PDC mode to use this command. Use INSTRUMENT:SElect to set the mode.

### Spectrum—Wideband ADC Dither

```
[ :SENSe ] :SPECTrum:WBIF:ADC:DITHer OFF | ON | 0 | 1
```

```
[ :SENSe ] :SPECTrum:WBIF:ADC:DITHer?
```

Turns the wideband dither signal on/off for Option 122 or 140. The control is independent of the standard narrowband ADC dither (SENSe:SPECTrum:ADC:DITHer:STATe). The “ADC dither” refers to the introduction of noise to the digitized steps of the analog-to-digital converter; the result is an improvement in amplitude accuracy. Use of the ADC dither, however, reduces dynamic range by approximately 3 dB.

This is an advanced control that normally does not need to be changed. It should only be turned off when measuring a noise-like signal and the 1 to 2 dB extra dynamic range is needed.

Factory Preset: On

State Saved: Not saved in instrument state.

Remarks: You must be in the Basic mode to use this command. Use INSTRUMENT:SElect to set the mode.

History: Added in PSA revision A.06.00.

### Spectrum—Wideband ADC Corrections

```
[ :SENSe ] :SPECTrum:WBIF:ADCCorrect OFF | ON | 0 | 1
```

```
[ :SENSe ] :SPECTrum:WBIF:ADCCorrect?
```

For Option 122 or 140 only. Turning corrections on performs an ADC calibration to reduce the spectral image and applies the corrections. This is an advanced control that normally does not need to be changed and the setting is global, so it also affects the WAVEform measurement.

Factory Preset: On

Couplings/

Dependencies Changes to this setting also affect the WAVEform measurement.

Remarks: You must be in the Basic mode to use this command.  
Use INSTRument:SElect to set the mode.

History: Added in PSA revision A.06.00.

### Spectrum—Wideband IF Filter Alpha

```
[ :SENSe ] :SPECTrum:WBIF:FILTer:ALPHa <numeric>
```

```
[ :SENSe ] :SPECTrum:WBIF:FILTer:ALPHa?
```

Sets the filter alpha for the wideband IF filter. This functionality is only available with the wideband options (122 or 140) and works with the filter types described in `SENSe:SPECTrum:WBIF:TYPE`.

Factory Preset: 0.5

Range: 0.01 to 1.00

Remarks: You must be in the Basic mode to use this command.  
Use `INSTRument:SElect` to set the mode.

History: Added in PSA revision A.06.00.

### Spectrum—Wideband IF Filter Bandwidth

```
[ :SENSe ] :SPECTrum:WBIF:FILTer:BANDwidth|BWIDth <numeric>
```

```
[ :SENSe ] :SPECTrum:WBIF:FILTer:BANDwidth|BWIDth?
```

Sets the bandwidth for the wideband IF filter. This specifies the bandwidth as a fraction of the sample rate. Sample rate can be calculated by taking  $1/\text{Time Spacing}$ . The value of the Time Spacing scaler can be found using `MEASure:SPECTrum1?`

This functionality is only available with the wideband options (122 or 140). It uses the filter types described in `SENSe:SPECTrum:WBIF:TYPE`.

Factory Preset: 0.5

Range: 0.01 to 1.00

Remarks: You must be in the Basic mode to use this command.  
Use `INSTRument:SElect` to set the mode.

History: Added in PSA revision A.06.00.

### Spectrum—Wideband IF Filter Type

```
[ :SENSe ] :SPECTrum:WBIF:FILTer [ :TYPE ]
```

```
NONE | GAUSSian | NYQuist | RNYQuist | RCOSine | RRCosine
```

```
[ :SENSe ] :SPECTrum:WBIF:FILTer [ :TYPE ] ?
```

Sets the filter type/shape for the wideband IF filter. The wideband hardware is only available with Option 122 or 140.

NONE - Applies no filtering. Therefore it ignores the filter alpha and filter bandwidth settings.

**GAUSSian** - Gaussian shape, where the filter bandwidth is set using `SENSE:SPECTrum:WBIF:FILTer:BAWIDth|BWIDth`. The filter alpha setting (`SENSE:SPECTrum:WBIF:FILTer:ALPHA`) is ignored with gaussian selected.

**NYQuist** - Nyquist filter shape.

**RNYQuist** - This root Nyquist filter has very abrupt cutoffs (that is, a very small filter alpha).

**RCOSine** - raised cosine filter, where the filter alpha is set using `SENSE:SPECTrum:WBIF:FILTer:ALPHA`.

**RRCosine** - root raised cosine filter, where the filter alpha is set using `SENSE:SPECTrum:WBIF:FILTer:ALPHA`.

Factory Preset: None

Remarks: You must be in the Basic mode to use this command.  
Use `INSTRument:SELEct` to set the mode.

History: Added in PSA revision A.06.00.

### Spectrum—Wideband IF Flatness Corrections

`[ :SENSe ] :SPECTrum:WBIF:FLATness OFF | ON | 0 | 1`

`[ :SENSe ] :SPECTrum:WBIF:FLATness?`

Turns IF flatness corrections on and off for the Option 122 or 140 wideband IF. The standard narrowband IF flatness control uses `SENSE:SPECTrum:BAWIDth|BWIDth:IF:FLATness`. This is an advanced control that normally does not need to be changed. And the setting is global, so it also affects the **WAVE**form measurement.

Factory Preset: ON

State Saved: Not saved in instrument state.

Couplings/

Dependencies Changes to this setting also affect the **WAVE**form measurement.

Remarks: You must be in the Basic mode to use this command.  
Use `INSTRument:SELEct` to set the mode.

History: Added in PSA revision A.06.00.

Front Panel

Access: **Measure, Spectrum, Meas Setup, Wideband Setup, Wideband Advanced, Analog Filter**

## Time Capture Commands

### Current Time Capture Record

`[ :SENSe ] :TCAPture:CRECord?`

Returns the current record that being read from the data capture buffer.

Remarks: You must be in the Basic mode to use this command.  
Use `INSTRument:SElect` to set the mode.

History: Added with PSA revision A.06.00

### First Record of the Time Capture

`[ :SENSe ] :TCAPture:FRECord <integer>`

`[ :SENSe ] :TCAPture:FRECord?`

Specifies the first data record that will be routed to the input to be played back. Use `SENSe:FEED` to select the internal data buffer as the RF input.

Factory Preset: 2

Remarks: You must be in the Basic mode to use this command.  
Use `INSTRument:SElect` to set the mode.

History: Added with PSA revision A.06.00

### Last Record of the Time Capture

`[ :SENSe ] :TCAPture:LRECord <integer>`

`[ :SENSe ] :TCAPture:LRECord?`

Specifies the last data record that will be routed to the input to be played back. Use `SENSe:FEED` to select the internal data buffer as the RF input.

Factory Preset: 2

Remarks: You must be in the Basic mode to use this command.  
Use `INSTRument:SElect` to set the mode.

History: Added with PSA revision A.06.00

### Next Time Capture Record

`[ :SENSe ] :TCAPture:NRECord <integer>`

`[ :SENSe ] :TCAPture:NRECord?`



Specifies the next record that will be read from the data capture buffer.

Factory Preset: 2

Example: To read a complete capture buffer:

Command	Description
:INIT:TCAP	Triggers the capture.
:TCAT:NREC1	Ensures the readback starts at the first record. (If you don't do this, the first READ will return the second record.)
:READ:WAV0?	Reads back the time record from the waveform measurement. (Use READ:SPEC0? for the spectrum measurement.)
:INIT:TCAP;*OPC?	Triggers a capture and waits for completion. It is critical that both commands be on the same line for the waiting to work properly.

Remarks: You must be in the Basic mode to use this command. Use INSTRUMENT:SElect to set the mode.

History: Added with PSA revision A.06.00

### Set Time Capture Time

**[ :SENSE ] :TCAPture:TIME <numeric>**

**[ :SENSE ] :TCAPture:TIME?**

Specifies the length of time that data will be captured.

Factory Preset: 102.500 ms

Range: 120  $\mu$ s to 512 s

Remarks: You must be in the Basic mode to use this command. Use INSTRUMENT:SElect to set the mode.

History: Added with PSA revision A.06.00

## Waveform (Time-Domain) Measurement

Commands for querying the waveform measurement results and for setting to the default values are found in the “[MEASure Group of Commands](#)” on page 175. The equivalent front panel keys for the parameters described in the following commands, are found under the **Meas Setup** key, after the **Waveform (Time Domain)** measurement has been selected from the **MEASURE** key menu.

### Waveform—Data Acquisition Packing

```
[ :SENSe ] :WAVeform:ACQuisition:PACKing  
AUTO | LONG | MEDium | SHORt
```

```
[ :SENSe ] :WAVeform:ACQuisition:PACKing?
```

This is an advanced control that normally does not need to be changed.

Factory Preset: AUTO

Remarks: You must be in the Basic, Analog Modulation, cdmaOne, cdma2000, 1xEV-DO, W-CDMA, GSM, EDGE, NADC, or PDC mode to use this command. Use INSTRument:SElect to set the mode.

### Waveform—ADC Dither Control

```
[ :SENSe ] :WAVeform:ADC:DITHer [ :STATe ] AUTO | ON | OFF | 2 | 1 | 0
```

```
[ :SENSe ] :WAVeform:ADC:DITHer [ :STATe ] ?
```

Turn the ADC dither on or off. This is an advanced control that normally does not need to be changed. The “ADC dither” refers to the introduction of noise to the digitized steps of the analog-to-digital converter; the result is an improvement in amplitude accuracy.

The wideband ADC dither (Opt 122 or 140) uses  
SENSe:WAVeform:WBIF:ADC:DITHer.

Factory Preset: AUTO

Remarks: You must be in the Basic, Analog Modulation, cdmaOne, cdma2000, 1xEV-DO, W-CDMA, GSM, EDGE, NADC, or PDC mode to use this command. Use INSTRument:SElect to set the mode.

### Waveform—Pre-ADC Bandpass Filter

```
[ :SENSe ] :WAVeform:ADC:FILTer [ :STATe ] OFF | ON | 0 | 1
```

```
[ :SENSe ] :WAVeform:ADC:FILTer [ :STATe ] ?
```

Turn the pre-ADC bandpass filter on or off. This is an Advanced control

that normally does not need to be changed.

Preset: OFF

Remarks: You must be in the Basic, Analog Modulation, cdmaOne, cdma2000, 1xEV-DO, W-CDMA, GSM, EDGE, NADC, or PDC mode to use this command. Use INSTRUMENT:SELEct to set the mode.

### Waveform—ADC Range

```
[ :SENSe] :WAVeform:ADC:RANGe
AUTO | APEak | APLOck | GROund | NONE | P0 | P6 | P12 | P18
```

```
[ :SENSe] :WAVeform:ADC:RANGe?
```

Select the range for the gain-ranging that is done in front of the ADC. This is an Advanced control that normally does not need to be changed.

AUTO - automatic range

Auto Peak (APEak) - automatically peak the range

Auto Peak Lock (APLOck)- automatically peak lock the range

GROund - ground

NONE - (PSA and 14-bit ADC E4406A) turn off auto-ranging without making any changes to the current setting.

M6 - (12-bit ADC E4406A) subtracts 6 dB of fixed gain across the range

P0 to P18 - (PSA and 14-bit ADC E4406A) adds 0 to 18 dB of fixed gain across the range

P0 to P24 - (12-bit ADC E4406A) adds 0 to 24 dB of fixed gain across the range

Factory Preset: AUTO

Remarks: You must be in the Basic, Analog Modulation, cdmaOne, cdma2000, 1xEV-DO, W-CDMA, GSM, EDGE, NADC, or PDC mode to use this command. Use INSTRUMENT:SELEct to set the mode.

### Waveform—Automatic Analog Anti-alias Filter

```
[ :SENSe ] :WAVeform:AFILter:AUTO OFF | ON | 0 | 1
```

```
[ :SENSe ] :WAVeform:AFILter:AUTO?
```

For Option 122 or 140 only. Sets the anti-alias filter selection to be done automatically or manually for measurements using the wideband IF path. It should be left on for calibrated measurements. When on, it uses the 80 MHz filter (Opt 122) or the 40 MHz filter (Opt 140) for measurements with bandwidths greater than 36 MHz. Otherwise it uses the 36 MHz filter.

Factory Preset: On

Remarks: You must be in the Basic mode to use this command.  
Use INSTRument:SElect to set the mode.

History: Added in PSA revision A.06.00.

### Waveform—Analog Anti-alias Filter Selection

```
[ :SENSe ] :WAVeform:AFILter: F80 | F40 | F36
```

```
[ :SENSe ] :WAVeform:AFILter?
```

For Option 122 or 140 only. Manually selects the anti-alias filter that will be used for measurements using the wideband IF path.

Factory Preset: F80 (Opt 122), F40 (Opt 140)

Remarks: You must be in the Basic mode to use this command.  
Use INSTRument:SElect to set the mode.

History: Changed in PSA revision A.08.00.

### Waveform—Sample Period (Aperture) Setting

```
[ :SENSe ] :WAVeform:APERture?
```

Returns the time between samples (sample period or aperture). This value is based on current resolution bandwidth, filter type, and decimation factor. Sample rate is the reciprocal of the period.

Remarks: You must be in the Basic, Analog Modulation, cdmaOne, cdma2000, 1xEV-DO, W-CDMA, GSM, EDGE, NADC, or PDC mode to use this command. Use INSTRument:SElect to set the mode.

History: PSA added revision A.04.00.

### Waveform—Number of Averages

`[ :SENSE ] :WAVEform:AVERage:COUNT <integer>`

`[ :SENSE ] :WAVEform:AVERage:COUNT?`

Set the number of sweeps that will be averaged. After the specified number of sweeps (average counts), the averaging mode (terminal control) setting determines the averaging action.

Factory Preset: 10

Range: 1 to 10,000

Remarks: You must be in the Basic, Analog Modulation, cdmaOne, cdma2000, 1xEV-DO, W-CDMA, GSM, EDGE, NADC, or PDC mode to use this command. Use INSTRUMENT:SELEct to set the mode.

### Waveform—Averaging State

`[ :SENSE ] :WAVEform:AVERage [ :STATE ] OFF | ON | 0 | 1`

`[ :SENSE ] :WAVEform:AVERage [ :STATE ] ?`

Turn averaging on or off.

Factory Preset: OFF

Remarks: You must be in the Basic, Analog Modulation, cdmaOne, cdma2000, 1xEV-DO, W-CDMA, GSM, EDGE, NADC, or PDC mode to use this command. Use INSTRUMENT:SELEct to set the mode.

### Waveform—Number of Time Averages

`[ :SENSE ] :WAVEform:AVERage:TACount <integer>`

`[ :SENSE ] :WAVEform:AVERage:TACount?`

Sets the number of time averages to be made when using the Option 122 or 140 wideband hardware. This averaging is much faster than the standard averaging. It is done before any measurement application averaging is done.

Factory Preset: 1

Range: 1 to 524288

Couplings/

Dependencies: To use this hardware averaging:

- The trigger source must be Frame.
- The signal should be a repetitive (periodic) signal.
- The number of samples in the measurement acquisition must be < 16384.

Remarks: You must be in the Basic mode to use this command. Use INSTRument:SElect to set the mode.

History: Added for PSA revision A.06.00.

### Waveform—Averaging Termination Control

```
[ :SENSe ] :WAVeform:AVERage:TCONtrol EXPonential | REPEAT
```

```
[ :SENSe ] :WAVeform:AVERage:TCONtrol?
```

Select the type of termination control used for the averaging function. This determines the averaging action after the specified number of ‘sweeps’ (average count) is reached.

EXPonential - After the average count has been reached, each successive data acquisition is exponentially weighted and combined with the existing average.

REPEAT - After reaching the average count, the averaging is reset and a new average is started.

Factory Preset: EXPonential

Remarks: You must be in the Basic, Analog Modulation, cdmaOne, cdma2000, 1xEV-DO, W-CDMA, GSM, EDGE, NADC, or PDC mode to use this command. Use INSTRument:SElect to set the mode.

### Waveform—Averaging Type

```
[ :SENSe ] :WAVeform:AVERage:TYPE  
LOG | MAXimum | MINimum | RMS | SCALar
```

```
[ :SENSe ] :WAVeform:AVERage:TYPE?
```

Select the type of averaging.

LOG - The log of the power is averaged. (This is also known as video averaging.)

MAXimum - The maximum values are retained.

MINimum - The minimum values are retained.

RMS - The power is averaged, providing the rms of the voltage.

Factory Preset: RMS

Remarks: You must be in the Basic, Analog Modulation, cdmaOne, cdma2000, 1xEV-DO, W-CDMA, GSM, EDGE, NADC, or PDC mode to use this command. Use INSTRUMENT:SElect to set the mode.

### Waveform—Resolution BW

```
[ :SENSE ] :WAVEform:BANDwidth|BWIDth[:RESolution] <freq>
```

```
[ :SENSE ] :WAVEform:BANDwidth|BWIDth[:RESolution] ?
```

Set the resolution bandwidth. This value is ignored if the function is auto-coupled.

Factory Preset: 20.0 kHz for NADC, PDC, cdma2000, W-CDMA, Basic, Service (E4406A)  
500.0 kHz for GSM  
2.0 MHz for cdmaOne

Range: 1.0 kHz to 8.0 MHz when  
SENSE:WAV:BWID:RES:TYPE GAUSSian  
  
100 mHz to 10.0 MHz when  
SENSE:WAV:BWID:RES:TYPE FLATtop  
  
PSA: 10.0 Hz to 10 MHz, for Basic Mode  
  
PSA Option 122: 10 kHz to 80 MHz, for Basic Mode  
  
PSA Option 140: 10 kHz to 40 MHz, for Basic Mode

Remarks: You must be in the Basic, Analog Modulation, cdmaOne, cdma2000, 1xEV-DO, W-CDMA, GSM, EDGE, NADC, or PDC mode to use this command. Use INSTRUMENT:SElect to set the mode.

Bandwidths > 6.7 MHz will require a slight increase in measurement time.

History: PSA modified in revision A.06.00.

### Waveform—Query Actual Resolution Bandwidth

`[[:SENSe]:WAVEform:BANDwidth[:RESolution]:ACTual?`

Due to memory constraints the actual resolution bandwidth value may vary from the value entered by the user. For most applications the resulting difference in value is inconsequential but for some it is necessary to know the actual value; this query retrieves the actual resolution bandwidth value.

Remarks: You must be in the Basic, Analog Modulation, cdmaOne, cdma2000, 1xEV-DO, W-CDMA, GSM, EDGE, NADC, or PDC mode to use this command. Use INSTRument:SElect to set the mode.

### Waveform—Resolution BW Filter Type

`[[:SENSe]:WAVEform:BANDwidth|BWIDth[:RESolution]:TYPE  
FLATtop|GAUSSian`

`[[:SENSe]:WAVEform:BANDwidth|BWIDth[:RESolution]:TYPE?`

Select the type of Resolution BW filter that is used. This is an Advanced control that normally does not need to be changed.

FLATtop - a filter with a flat amplitude response, which provides the best amplitude accuracy.

GAUSSian - a filter with Gaussian characteristics, which provides the best pulse response.

Factory Preset: GAUSSian

Remarks: You must be in the Basic, Analog Modulation, cdmaOne, cdma2000, 1xEV-DO, W-CDMA, GSM, EDGE, NADC, or PDC mode to use this command. Use INSTRument:SElect to set the mode.

### Waveform—Wideband IF Data Block Size

`[[:SENSe]:WAVEform:BSIZE?`

For Option 122 or 140 only. The query returns the wideband IF sample data block size. Block size is coupled with the IF bandwidth and the measurement time. This value is ignored if the function is auto-coupled.

Factory Preset: 2728

Range: 1 to 1000001

Remarks: You must be in the Basic mode to use this command. Use INSTRument:SElect to set the mode.

History: Added in revision A.06.00.



### Waveform—Decimation of Waveform Display

`[ :SENSE ] :WAVEform:DECimate [ :FACTor ] <integer>`

`[ :SENSe ] :WAVEform:DECimate [ :FACTor ] ?`

Set the amount of data decimation done on the IQ data stream. For example, if 4 is selected, three out of every four data points will be thrown away. So every 4th data point will be kept.

Factory Preset: 1

Range: 1 to 4

Remarks: You must be in the Basic, Analog Modulation, cdmaOne, cdma2000, 1xEV-DO, W-CDMA, GSM, EDGE, NADC, or PDC mode to use this command. Use INSTRUMENT:SElect to set the mode.

### Waveform—Control Decimation of Waveform Display

`[ :SENSe ] :WAVEform:DECimate:STATe OFF | ON | 0 | 1`

`[ :SENSe ] :WAVEform:DECimate:STATe?`

Set the amount of data decimation done by the hardware in order to decrease the number of acquired points in a long capture time. This is the amount of data that the measurement ignores.

Factory Preset: OFF

Remarks: You must be in the Basic, Analog Modulation, cdmaOne, cdma2000, 1xEV-DO, W-CDMA, GSM, EDGE, NADC, or PDC mode to use this command. Use INSTRUMENT:SElect to set the mode.

### Waveform—Wideband IF Path Gain Selection

`[ :SENSe ] :WAVEform:IFGain <numeric>`

`[ :SENSe ] :WAVEform:IFGain?`

Sets the gain for the wideband IF path. You must have Option 122 or 140 to use this command and you must have selected SENSE:WAVEform:IFPath WIDE. Increasing the gain will improve sensitivity. Increasing the gain increases the amplitude of small signals but you must be careful not to overdrive the analyzer.

Factory Preset: 0 dB

Range: -12 to +12 dB

Remarks: You must be in the Basic mode to use this command. Use INSTRUMENT:SElect to set the mode.

History: Added for PSA revision A.06.00.

### Waveform—Wideband IF Path Selection

```
[ :SENSe ] :WAVeform:IFPath NARRow|WIDE
```

```
[ :SENSe ] :WAVeform:IFPath?
```

You must have Option 122 or 140 for this command. It selects either the wideband input hardware or the standard “narrowband” path.

Factory Preset: Narrow

Couplings/

Dependencies: Narrow is not available unless option B7J is available.

Narrow is not available for frequencies >3 GHz.

Remarks: You must be in the Basic mode to use this command.  
Use INSTRument:SElect to set the mode.

Remarks: You must be in the Basic mode to use this command.  
Use INSTRument:SElect to set the mode.

History: Added for PSA revision A.06.00.

### Waveform—Stop Calculation of Power Trace

```
[ :SENSe ] :WAVeform:NCPTrace OFF|ON|0|1
```

```
[ :SENSe ] :WAVeform:NCPTrace?
```

Disables computation of the power trace so the results are available faster. This turns off trace updates. It means that the scalar results are not available when querying MEASure:WAVeform1? Turning off the display DISPlay:ENABle OFF also increases the measurement speed.

Factory Preset On

Remarks: You must be in the Basic mode to use this command.  
Use INSTRument:SElect to set the mode.

History: Added for PSA revision A.06.00.

### Waveform—Sample Rate

```
[ :SENSe ] :WAVeform:SRATE <freq>
```

```
[ :SENSe ] :WAVeform:SRATE?
```

Manual setting for the sample rate of the Option 122 or 140 wideband IF hardware path that is coupled with the filter shape and bandwidth, and the maximum available captured data size. The IF bandwidth will be set to  $0.8 \times$  sample rate.

Factory Preset 100.0 MHz.

Range: 125 kHz to 100.0 MHz  
 Remarks: You must be in the Basic mode to use this command. Use INSTRument:SElect to set the mode.  
 History: Added for PSA revision A.06.00.

### Waveform—Sweep (Acquisition) Time

`[ :SENSE ] :WAVEform:SWEep:TIME <time>`

`[ :SENSE ] :WAVEform:SWEep:TIME?`

Set the measurement acquisition time. It is used to specify the length of the time capture record.

Factory Preset: 2.0 ms  
 100.0 ms, for Basic Mode  
 10.0 ms, for NADC, PDC

Range: 100 ns to 100 s

Default Unit: seconds

Remarks: You must be in the Basic, Analog Modulation, cdmaOne, cdma2000, 1xEV-DO, W-CDMA, GSM, EDGE, NADC, or PDC mode to use this command. Use INSTRument:SElect to set the mode.

### Waveform—Trigger Error Offset

`[ :SENSE ] :WAVEform:TRIGger:EOFFset?`

For PSA Option 122 or 140 only. This command returns the current value of the trigger error offset. During normal operation, the trigger interpolation makes the trigger error offset 0 seconds. Trigger interpolation can be turned off with `SENSE:WAVEform:TRIGger:INTerpolation`. Then you can query the error and remove it, if needed.

This is an advanced function that usually does not need to be changed. The functionality is only available when you are using the wideband IF hardware path and have an external trigger source. If you are using the SPECTrum measurement, the error offset value is one of the scaler values returned with `MEAS:SPEC1`. It is the “first time point” value.

Factory Preset: 0 seconds

Remarks: You must be in the Basic mode to use this command. Use INSTRument:SElect to set the mode.

History: Added in PSA revision A.06.00

### Waveform—Trigger Interpolation

```
[[:SENSe]:WAVeform:TRIGger:INTerpolation OFF|ON|0|1
```

```
[[:SENSe]:WAVeform:TRIGger:INTerpolation?
```

For PSA Option 122 or 140 only. During normal operation trigger interpolation is on and the trigger error offset is 0 seconds. At low sample rates the trigger interpolation can result in instrument unlock errors, so you may turn it off. If it is turned off, you can query the trigger offset with `SENSe:WAVeform:TRIGger:EOFFset?` This is an advanced function that usually does not need to be changed.

This function is only available when you are using the wideband IF hardware path and have an external trigger source.

Factory Preset: On

Remarks: You must be in the Basic mode to use this command.  
Use `INSTRument:SELEct` to set the mode.

History: Added with PSA revision A.06.00

### Waveform—Trigger Source

```
[[:SENSe]:WAVeform:TRIGger:SOURce EXTErnal [1] |  
EXTErnal2 | FRAME | IF | IMMEDIATE | LINE | RFBURSt
```

```
[[:SENSe]:WAVeform:TRIGger:SOURce?
```

Select the trigger source used to control the data acquisitions.

EXTErnal 1 - front panel external trigger input

EXTErnal 2 - rear panel external trigger input

FRAMe - internal frame timer from front panel input

IF - internal IF envelope (video) trigger

IMMEDIATE - the next data acquisition is immediately taken (also called free run)

LINE - internal line trigger

RFBURSt - wideband RF burst envelope trigger that has automatic level control for periodic burst signals (not available when using Option 122 or 140)

Factory Preset: IMMEDIATE (free run), for Basic, cdmaOne, NADC, PDC mode

RFBURSt, for GSM modes

Remarks: You must be in the Basic, Analog Modulation, cdmaOne, cdma2000, 1xEV-DO, W-CDMA, GSM, EDGE, NADC, or PDC mode to use this command. Use INSTRUMENT:SElect to set the mode.

### Waveform—Wideband ADC Dither

`[ :SENSe ] :WAVeform:WBIF:ADC:DITHer OFF | ON | 0 | 1`

`[ :SENSe ] :WAVeform:WBIF:ADC:DITHer?`

Turns the wideband dither signal on/off for Option 122 or 140. The control is independent of the standard narrowband ADC dither (SENSe:WAVeform:ADC:DITHer:STATe). The “ADC dither” refers to the introduction of noise to the digitized steps of the analog-to-digital converter; the result is an improvement in amplitude accuracy. Use of the ADC dither, however, reduces dynamic range by approximately 3 dB.

This is an advanced control that normally does not need to be changed. It should only be turned off when measuring a noise-like signal and the 1 to 2 dB extra dynamic range is needed.

Factory Preset: On

Remarks: You must be in the Basic mode to use this command. Use INSTRUMENT:SElect to set the mode.

History: Added in PSA revision A.06.00.

### Waveform—Wideband ADC Corrections

`[ :SENSe ] :WAVeform:WBIF:ADCCorrect OFF | ON | 0 | 1`

`[ :SENSe ] :WAVeform:WBIF:ADCCorrect?`

Turning corrections on performs an ADC calibration to reduce the spectral image and applies the corrections. This is an advanced control that normally does not need to be changed and the setting is global, so it also affects the SPECTrum measurement.

Factory Preset: On

State Saved: Not saved in instrument state.

Couplings/  
Dependencies Changes to this setting also affect the SPECTrum measurement.

Remarks: You must be in the Basic mode to use this command. Use INSTRUMENT:SElect to set the mode.

History: Added in PSA revision A.06.00.

### Waveform—Wideband IF Filter Alpha

```
[ :SENSe ] :WAVeform:WBIF:FILTer:ALPHA <numeric>
```

```
[ :SENSe ] :WAVeform:WBIF:FILTer:ALPHA?
```

Sets the bandwidth for the wideband IF filter. This specifies the bandwidth as a fraction of the sample rate, that can be queried using `SENSe:WAVeform:SRATe`. This functionality is only available with the wideband options (122 or 140) and works with the filter types described in `SENSe:WAVeform:WBIF:TYPE`.

Factory Preset: 0.3

Range: 0.01 to 1.00

Remarks: You must be in the Basic mode to use this command.  
Use `INSTRument:SElect` to set the mode.

History: Added for PSA revision A.06.00.

### Waveform—Wideband IF Filter Bandwidth

```
[ :SENSe ] :WAVeform:WBIF:FILTer:BANDwidth|BWIDth <numeric>
```

```
[ :SENSe ] :WAVeform:WBIF:FILTer:BANDwidth|BWIDth?
```

Sets the bandwidth for the wideband IF filter. This specifies the bandwidth as a fraction of the sample rate. Sample rate can be queried using `SENSe:WAVeform:SRATe`.

This functionality is only available with the wideband options (122 or 140). It works with the filter types described in `SENSe:WAVeform:WBIF:TYPE`.

Factory Preset: 0.5

Range: 0.01 to 1.00

Remarks: You must be in the Basic mode to use this command.  
Use `INSTRument:SElect` to set the mode.

History: Added for PSA revision A.06.00.

### Waveform—Wideband IF Filter Type

```
[ :SENSe ] :WAVeform:WBIF:FILTer [ :TYPE ]
```

```
NONE | GAUSSian | NYQuist | RNYQuist | RCOSine | RRCosine
```

```
[ :SENSe ] :WAVeform:WBIF:FILTer [ :TYPE ] ?
```

Sets the filter type/shape for the wideband IF filter. The wideband hardware is only available with Option 122 or 140.

NONE - Applies no filtering. Therefore it ignores the filter alpha and

filter bandwidth settings.

**GAUSSian** - Gaussian shape, where the filter bandwidth is set using `SENSE:SPECTrum:WBIF:FILTer:BAWIDth|BWIDth`. The filter alpha setting (`SENSE:SPECTrum:WBIF:FILTer:ALPHa`) is ignored with gaussian selected.

**NYQuist** - Nyquist filter shape.

**RNYQuist** - This root Nyquist filter has very abrupt cutoffs (that is, a very small filter alpha).

**RCOSine** - raised cosine filter, where the filter alpha is set using `SENSE:SPECTrum:WBIF:FILTer:ALPHa`.

**RRCosine** - root raised cosine filter, where the filter alpha is set using `SENSE:SPECTrum:WBIF:FILTer:ALPHa`.

Factory Preset: None

Remarks: You must be in the Basic mode to use this command. Use `INSTrument:SElect` to set the mode.

History: Added for PSA revision A.06.00.

### Waveform—Wideband IF Flatness Corrections

`[ :SENSe ] :WAVEform:WBIF:FLATness OFF | ON | 0 | 1`

`[ :SENSe ] :WAVEform:WBIF:FLATness?`

Turns IF flatness corrections on and off for the wideband IF (Option 122 or 140). This is an advanced control that normally does not need to be changed. And the setting is global, so it also affects the `SPECTrum` measurement.

Factory Preset: ON

State Saved: Not saved in instrument state.

Couplings/

Dependencies Changes to this setting also affect the `SPECTrum` measurement.

Remarks: You must be in the Basic mode to use this command. Use `INSTrument:SElect` to set the mode.

History: Added in PSA revision A.06.00.

Front Panel

Access: **Measure, Waveform, Meas Setup, Wideband Setup, Advanced, Analog Filter**

## TRIGger Subsystem

The Trigger Subsystem is used to set the controls and parameters associated with triggering the data acquisitions. Other trigger-related commands are found in the INITiate and ABORt subsystems.

The trigger parameters are global within a selected Mode. The commands in the TRIGger subsystem set up the way the triggers function, but selection of the trigger source is made from each measurement. There is a separate trigger source command in the SENSE:<meas> subsystem for each measurement. The equivalent front panel keys for the parameters described in the following commands, can be found under the **Mode Setup, Trigger** key.

### Automatic Trigger Control

```
:TRIGger[:SEquence]:AUTO:STATE OFF|ON|0|1
```

```
:TRIGger[:SEquence]:AUTO:STATE?
```

Turns the automatic trigger function on and off. This function causes a trigger to occur if the designated time has elapsed and no trigger occurred. It can be used with unpredictable trigger sources, like external or burst, to make sure a measurement is initiated even if a trigger doesn't occur. Use TRIGger[:SEquence]:AUTO[:TIME] to set the time limit.

Factory Preset  
and \*RST      Off for cdma2000, W-CDMA, NADC, PDC, 1xEV-DO

Front Panel  
Access      **Mode Setup, Trigger, Auto Trig**

### Automatic Trigger Time

```
:TRIGger[:SEquence]:AUTO[:TIME] <time>
```

```
:TRIGger[:SEquence]:AUTO[:TIME]?
```

After the measurement is activated the instrument will take a data acquisition immediately upon receiving a signal from the selected trigger source. If no trigger signal is received by the end of the time specified in this command, a data acquisition is taken anyway. TRIGger[:SEquence]:AUTO:STATE must be on.

Factory Preset: 100.0 ms

Range:            1.0 ms to 1000.0 s  
                  0.0 to 1000.0 s for cdma2000, W-CDMA, 1xEV-DO



Default Unit: seconds  
Front Panel  
Access **Mode Setup, Trigger, Auto Trig**

## External Trigger Delay

```
:TRIGger[:SEquence]:EXTernal[1]|2:DElay <time>
:TRIGger[:SEquence]:EXTernal[1]|2:DElay?
```

Set the trigger delay when using an external trigger. Set the trigger value to zero (0) seconds to turn off the delay.

EXT or EXT1 is the front panel trigger input.

EXT2 is the rear panel trigger input.

Factory Preset: 0.0 s  
Range: -100.0 ms to 500.0 ms  
Default Unit: seconds  
Front Panel  
Access: **Mode Setup, Trigger, Ext Rear (or Ext Front), Delay**

## External Trigger Level

```
:TRIGger[:SEquence]:EXTernal[1]|2:LEvel <voltage>
:TRIGger[:SEquence]:EXTernal[1]|2:LEvel?
```

Set the trigger level when using an external trigger input.

EXT or EXT1 is the front panel trigger input

EXT2 is the rear panel trigger input

Factory Preset: 2.0 V  
Range: -5.0 to +5.0 V  
Default Unit: volts  
Front Panel  
Access: **Mode Setup, Trigger, Ext Rear (or Ext Front), Level**

## External Trigger Slope

```
:TRIGger[:SEQuence]:EXTErnal[1]|2:SLOPe NEGative|POSitive
```

```
:TRIGger[:SEQuence]:EXTErnal[1]|2:SLOPe?
```

Sets the trigger slope of an external trigger input to either NEGative or POSitive.

EXT or EXT1 is the front panel trigger input.

EXT2 is the rear panel trigger input.

Factory Preset: Positive

Front Panel

Access: **Mode Setup, Trigger, Ext Rear (or Ext Front), Slope**

## Frame Trigger Adjust

```
:TRIGger[:SEQuence]:FRAMe:ADJust <time>
```

Lets you advance the phase of the frame trigger by the specified amount. It does not change the period of the trigger waveform. If the command is sent multiple times, it advances the phase of the frame trigger more each time it is sent.

Factory Preset: 0.0 s

Range: 0.0 to 10.0 s

Default Unit: seconds

Front Panel

Access: None

## Frame Trigger Period

```
:TRIGger[:SEQuence]:FRAMe:PERiod <time>
```

```
:TRIGger[:SEQuence]:FRAMe:PERiod?
```

Set the frame period that you want when using the external frame timer trigger. If the traffic rate is changed, the value of the frame period is initialized to the preset value.

Factory Preset: 250.0  $\mu$ s for Basic, cdmaOne

4.615383 ms, for GSM

26.666667 ms for cdma2000 and 1xEV-DO

10.0 ms (1 radio frame) for W-CDMA

20.0 ms with rate=full for NADC, PDC

40.0 ms with rate=half for NADC, PDC

Range: 0.0 ms to 559.0 ms for Basic, cdmaOne, GSM, EDGE, cdma2000, W-CDMA, 1xEV-DO  
1.0 ms to 559.0 ms for NADC, PDC

Default Unit: seconds

Front Panel  
Access: **Mode Setup, Trigger, Frame Timer, Period**

## Frame Trigger Sync Source

```
:TRIGger[:SEquence]:FRAMe:SYNC EXTFront|EXTRear|OFF
:TRIGger[:SEquence]:FRAMe:SYNC?
```

Selects the input port location for the external frame trigger that you are using.

Factory Preset: Off

Remarks: You must be in the Basic, cdmaOne, GSM, EDGE, NADC, PDC, Service mode to use this command. Use INSTRument:SElect to set the mode.

Front Panel  
Access: **Mode Setup, Trigger, Frame Timer, Sync Source**

History Changed firmware revision A.05.00.

## Frame Trigger Synchronization Offset

```
:TRIGger[:SEquence]:FRAMe:SYNC:OFFSet <time>
:TRIGger[:SEquence]:FRAMe:SYNC:OFFSet?
```

Lets you adjust the frame triggering with respect to the external trigger input that you are using.

Factory Preset: 0.0 s

Range: 0.0 to 10.0 s

Default Unit: seconds

Remarks: You must be in the Basic, cdmaOne, GSM, EDGE, NADC, PDC, Service mode to use this command. Use INSTRument:SElect to set the mode.

History: Revision A.03.27 or later

Front Pane Access: **Mode Setup, Trigger, Frame Timer, Offset**

## Trigger Holdoff

**:TRIGger[:SEquence]:HOLDoff <time>**

**:TRIGger[:SEquence]:HOLDoff?**

Set a value of the holdoff time between triggers. After a trigger, another trigger will not be allowed until the holdoff time expires. This parameter affects all trigger sources.

Factory Preset: 0.0 s

10.0 ms for NADC or PDC

Range: 0.0 to 500.0 ms

Default Unit: seconds

Front Panel

Access: **Mode Setup, Trigger, Trigger Holdoff**

## Video (IF) Trigger Delay

**:TRIGger[:SEquence]:IF:DElay <time>**

**:TRIGger[:SEquence]:IF:DElay?**

Set a value of the trigger delay of the IF (video) trigger (signal after the resolution BW filter).

Factory Preset: 0.0 s

Range: -100.0 ms to 500.0 ms

Default Unit: seconds

Front Panel

Access: **Mode Setup, Trigger, Video (IF Envlp), Delay**

## Video (IF) Trigger Level

**:TRIGger[:SEquence]:IF:LEVel <ampl>**

**:TRIGger[:SEquence]:IF:LEVel?**

Set the trigger level when using the IF (video) trigger.

Factory Preset: -6.0 dBm for cdmaOne, GSM, EDGE, Basic,  
cdma2000, W-CDMA, 1xEV-DO

-30.0 dBm for NADC, PDC

Range: -200.0 to 50.0 dBm

Default Unit: dBm

Front Panel  
 Access: **Mode Setup, Trigger, Video (IF Envlp), Level**

### Video (IF) Trigger Slope

**:TRIGger[:SEQuence]:IF:SLOPe** NEGative|POSitive

**:TRIGger[:SEQuence]:IF:SLOPe?**

Sets the trigger slope when using the IF (video) trigger, to either NEGative or POSitive.

Factory Preset: Positive

Front Panel  
 Access: **Mode Setup, Trigger, Video (IF Envlp), Slope**

### RF Burst Trigger Delay

**:TRIGger[:SEQuence]:RFBurst:DElay** <time>

**:TRIGger[:SEQuence]:RFBurst:DElay?**

Set the trigger delay when using the RF burst (wideband) trigger.

Factory Preset: 0.0  $\mu$ s

Range: -100.0 ms to 500.0 ms

Default Unit: seconds

Front Panel  
 Access: **Mode Setup, Trigger, RF Burst, Delay**

### RF Burst Trigger Level

**:TRIGger[:SEQuence]:RFBurst:LEVel** <rel\_power>

**:TRIGger[:SEQuence]:RFBurst:LEVel?**

Set the trigger level when using the RF Burst (wideband) Trigger. The value is relative to the peak of the signal. RF Burst is also known as RF Envelope.

Factory Preset: -6.0 dB

Range: -25.0 to 0.0 dB  
 -200.0 to 0.0 dB for NADC, PDC

Default Unit: dB

Front Panel Access: **Mode Setup, Trigger, RF Burst, Peak Level**

## RF Burst Trigger Slope

`:TRIGger[:SEQuence]:RFBurst:SLOPe NEGative|POSitive`

`:TRIGger[:SEQuence]:RFBurst:SLOPe?`

Set the trigger slope when using the RF Burst (wideband) Trigger.

Factory Preset: Positive

Remarks: You must be in the cdmaOne, cdma2000, W-CDMA mode to use this command. Use `:INSTrument:SElect` to set the mode.

Front Panel

Access: **Mode Setup, Trigger, RF Burst, Slope**

---

## 5 Concepts

This chapter provides details about the PSA Basic Mode measurements, and explains how the various measurements are performed by the instrument. Suggestions for optimizing and troubleshooting your setup are provided, along with a list of related Agilent documents that are referenced for further information.

## Spectrum (Frequency Domain) Measurement Concepts

### Purpose

The spectrum measurement provides spectrum analysis capability for the instrument. The control of the measurement was designed to be familiar to those who are accustomed to using swept spectrum analyzers.

This measurement is FFT (Fast Fourier Transform) based. The FFT-specific parameters are located in the **Advanced** menu. Also available under basic mode spectrum measurements is an I/Q window, which shows the I and Q signal waveforms in parameters of voltage versus time. The advantage of having an I/Q view available while in the spectrum measurement is that it allows you to view complex components of the same signal without changing settings or measurements.

### Measurement Method

The measurement uses digital signal processing to sample the input signal and convert it to the frequency domain. With the instrument tuned to a fixed center frequency, samples are digitized at a high rate, converted to I and Q components with DSP hardware, and then converted to the frequency domain with FFT software.

### Troubleshooting Hints

Changes made by the user to advanced spectrum settings, particularly to ADC range settings, can inadvertently result in spectrum measurements that are invalid and cause error messages to appear. Care needs to be taken when using advanced features.



---

## Waveform (Time Domain) Measurement Concepts

### Purpose

The waveform measurement is a generic measurement for viewing the input signal waveforms in the time domain. This measurement is how the instrument performs the zero span functionality found in traditional spectrum analyzers.

Basic mode waveform measurement data may be displayed using either a Signal Envelope window, or an I/Q window which shows the I and Q signal waveforms in parameters of voltage versus time. The advantage of having an I/Q view available while making a waveform measurement is that it allows you to view complex components of the same signal without changing settings or measurements.

For E4406A, an I/Q Polar display is also available to view the I and Q waveforms in a polar plot. This display shows the instantaneous relationship between the I and Q waveform voltages.

The waveform measurement can be used to perform general purpose power measurements in the time domain with excellent accuracy.

### Measurement Method

The instrument makes repeated power measurements at a set frequency, similar to the way a swept-tuned spectrum analyzer makes zero span measurements. The input analog signal is converted to a digital signal, which then is processed into a representation of a waveform measurement. The measurement relies on a high rate of sampling to create an accurate representation of a time domain signal.

---

## Power Stat CCDF Measurement Concepts

### Purpose

Many of the digitally modulated signals now look noise-like in the frequency domain. This means that statistical measurements of the signals can be a useful characterization. Power Complimentary Cumulative Distribution Function (CCDF) curves characterize the higher level power statistics of a digitally modulated signal. These curves can be useful in determining design parameters for digital communications systems.

### Measurement Method

The power measured in power statistics CCDF curves is actually instantaneous envelope power defined by the equation:

$$P = (I^2 + Q^2) / Z_0$$

Where I and Q are the quadrature voltage components of the waveform, and  $Z_0$  is the characteristic impedance.

A CCDF curve is defined by how much time the waveform spends at or above a given power level. The percent of time spent at or above the level defines the probability for that particular power level. For capturing a lower probability, down to 0.0001%, this measurement is made in the single mode by pressing the **Single** key on the front panel of the analyzer.

To make the power statistics CCDF measurement, the instrument uses digital signal processing (DSP) to sample the input signal in the channel bandwidth. The Gaussian distribution line as the band-limited Gaussian noise CCDF reference line, the user-definable reference trace, and the currently measured trace can be displayed on a semi-log graph. If the currently measured trace is above the user reference trace, it means that the higher peak power levels, against the average power, are included in the input signal.

### Troubleshooting Hints

The power statistics CCDF measurement can be affected by many factors. For example, modulation filtering, modulation format, combining the multiple signals at different frequencies, number of active codes, and correlation between symbols on different codes with spread spectrum systems will all affect the measurement results. These factors are all related to modulation and signal parameters. External factors such as signal compression and expansion by nonlinear components, group delay distortion from filtering, and power control within the observation interval also affect the measurement.

## PSA Options 122 and 140 Wideband Digitizer

This section describes several new features that are available with PSA Option 122 or 140 Wideband IF. It also describes some existing features that work differently and provides some hints for making measurements when using the Option 122 or 140 hardware.

PSA Options 122 and 140 offer 80 MHz or 40 MHz real time data capture, respectively. The acquisition system captures  $200 \times 10^6$  samples/sec. That data is then passed through a digital IQ converter that also applies flatness correction. At the output of the IQ converter, the data rate is  $100 \times 10^6$  complex samples per second. Following the IQ converter is an arbitrary resampler, so the system is able to provide any sample rate from 12.5 kHz to 100 MHz. If you are using the Waveform measurement in Basic mode, you can set the output sample rate directly. If you are using the Spectrum measurement, the sample rate is inferred from the requested span, and the sample rate is limited to 100 MHz divided by powers of two ( $2^x$ ).

Following the resampler is a user-selectable channel filter. The data flows from the channel filter to a DSP block that manages the triggering and storing into memory.

Note that when it is resampling the data, the instrument first applies a digital filter to remove signals and noise above the resampled Nyquist rate. This has the significant benefit of reducing the total noise per sample linearly with the sample rate reduction.

### Trigger System Differences

The triggering subsystem is shared by the Spectrum and Waveform measurements. They can have separate trigger types, but the trigger parameters and menus are shared. There are some differences between the triggering while in the standard narrow band operation and in the wideband operation. These are summarized below.

Table 5-1

**Options 122 and 140 Triggering Summary**

Trigger Type	Wideband Operation Functionality
Free Run	Same as narrowband operation.
Video	Same functionality as narrowband operation. In addition, the holdoff for negative slope triggers has been redefined.
RF Burst	Not available in wideband operation.

Table 5-1

Options 122 and 140 Triggering Summary

Trigger Type	Wideband Operation Functionality
External	Same functionality as narrowband operation. In addition, trigger errors due to internal clock boundaries are removed by interpolating the time trace prior to display.
Frame	Most functionality is different from narrowband operation.
Line	Same as narrowband operation.

### All Trigger Types

One significant difference is common to all the triggering types. Options 122 and 140 have a different trigger holdoff implementation. When using the standard narrow band IF path operation, selecting a trigger holdoff ensures that time between two consecutive triggers is at least the trigger holdoff.

When using wide band operation, selecting a trigger holdoff ensures that no trigger events occur in the holdoff period immediately before an acceptable trigger event. This is particularly useful when doing video trigger. It allows you to avoid triggering on events that are inside a pulse. You would enter a trigger holdoff that is slightly longer than the pulse width.

### Video Trigger

In wideband operation, the video trigger is implemented using digital hardware that monitors the time data after it has gone through I/Q conversion, down-sampling, and filtering. That is, it triggers using the data that will become the displayed time-trace data. You can select the trigger level, set positive/negative trigger delay, and select triggering on either a rising or a falling edge.

The trigger holdoff with rising edge triggering works differently than with falling edge triggering. When the trigger is set to a rising edge, a trigger holdoff ensures that no trigger occurs for the trigger holdoff period immediately before the trigger. This can be very useful when triggering on a pulsed signal. It allows you to trigger only at the end of the pulse off period.

The trigger holdoff functionality changes when the trigger is set to falling edge. The holdoff is the minimum period of time after a falling edge occurs that the trigger signal must stay below the trigger

threshold, before that falling edge is considered a valid trigger. This lets you to set up a trigger on the falling edge of a pulsed signal where the pulse has lots of internal power variations that would otherwise cause false triggers.

## Frame Trigger

The frame trigger functionality in Options 122 and 140 wideband operation is different than in narrowband operation because wider bandwidths have more difficult timing constraints. Wideband operation does not support an arbitrary frame period. It only allows frame periods that are an integer number of output samples. This requirement allows the instrument to use the very precise sample clock as the basis for the timer, achieving picosecond accuracy. Because the trigger is internally generated, the only necessary connection from the signal source is a common 10 MHz reference.

Since the frame period must be an integer number of sample clock periods, values entered from the front panel may be truncated slightly. This is more noticeable in the Spectrum measurement, because the sample rate is inferred from the span and is also limited to 100 MHz divided by powers of two ( $2^x$ ). For example, for spans  $>40$  MHz, the PSA will use 100 Msample/sec. For spans  $>20$  and  $\leq 40$  MHz, the PSA will use 50 Msample/sec. Therefore, in narrow spans it can be difficult to get a frame period that is exactly what you want.

The Waveform measurement is more flexible because the output sample rate is always  $5/4$  of the IF Bandwidth and you can directly set the sample rate. The front panel resolution is limited by the display space, but the SCPI sample rate resolution is 14 digits.

The frame trigger can be synchronized to an external trigger. So you can control exactly where it occurs within the frame acquisition. In narrow band operation it is designed to be driven by an infrequent sync trigger, and it synchronizes to that trigger whenever it occurs. This type of synchronization might be used when measuring signals from a cellular base station with a 1 Hz sync pulse.

Wideband operation uses the frame sync differently. Because the internal timing is so accurate, the sync is used only one time, and that is at start up. After that first synchronization, the trigger relies on its own internal timing. To force a re-synchronization, turn the

sync source off, then back on. Note that changing parameters or doing alignments will also cause the instrument to re-synchronize the frame trigger during wideband operation.

---

**NOTE**

When Frame trigger is operating properly, the time and frequency traces will appear to freeze with a small amount of noise visible. If the time trace shows movement then the trigger period is not right. Once the time trace freezes, you can use the frame timer offset to scan to different parts of the frame.

---

**External Trigger**

The PSA offers two external trigger inputs. One is on the front panel and one is on the rear. The function of the external trigger is essentially the same between wideband and narrowband operation.

Most digital acquisition systems only return the sample that was taken nearest to the desired trigger point. Because the external trigger is not synchronized with the sample clock, this error shows up as a measurement-to-measurement jitter on consecutive sweeps. The PSA has internal timers that measure the time between the external trigger event and the next available output sample. In narrowband operation you can query the trigger error using SCPI. In wideband operation, the instrument uses the DSP hardware to interpolate the time data so that the trigger error is removed. The result is that the wideband IF path has *very* low trigger jitter. At 100 Msample/sec, the typical trigger jitter will be below 1.5 ns peak-to-peak. The trigger jitter degrades somewhat at lower sample rates, but not one-for-one.

Because of processing time constraints, deep capture data is not interpolated to remove trigger error.

**Line Trigger** The line trigger uses the frequency of the input AC power waveform as the trigger source. The narrowband and wideband operations are nearly the same. However, wideband operation uses interpolation to remove any trigger error due to clock truncation, similar to the external trigger error correction.

**Fast Hardware Averaging**

The PSA Options 122 and 140 have hardware designed to average time traces as they are acquired. This capability can be used with the precision frame trigger described in [“Frame Trigger” on page 245](#). Together they do complex time domain averaging that can reduce the

noise on your signal up to 30 dB.

In order to perform the averaging, the input signal has to be repetitive and the phase must be fixed. This means that the signal source itself has to be repetitive and locked to a common 10 MHz reference. Any up or down converters in the signal path must also be locked to the common 10 MHz reference.

In addition, the signal repetition rate has to be known and it has to be an integer number of output samples. (See [“Frame Trigger” on page 245](#).) If you are using the waveform measurement, you can adjust the sample rate to match the signal period. Sometimes the signal period is not an integer number of microseconds (for example, a repetition rate of 27 1/3 kHz). In that case, try using a frame rate that is an integer number of repetitions of the signal rate.

---

**NOTE**

The hardware averaging can only be used with the Frame Trigger.

Enter the number of time averages by selecting **Meas Setup, Average, Time Avg Num**. When the hardware averager is used it adds only a few microseconds of overhead. In most cases, the acquisition time will be determined by the frame period. For example, to take 100 averages at a 100 microsecond frame rate will take very close to  $100 \times 100 \times 10^{-6} \text{s} = 10 \text{ ms}$ .

---

**NOTE**

If the signal magnitude drops when time averaging is turned on, the frame trigger is not set to the correct period. Turn time averaging off by setting **Time Avg Num** to 1. Then adjust the frame timer period and/or the sample rate to get the correct period.

Note that the frame triggering must be operating properly. The time and frequency traces will appear to freeze with a small amount of noise visible if the trigger period is right.

---

## Deep Data Captures

The PSA Options 122 and 140 can store up to  $128 \times 10^6$  samples using the deep capture feature. That corresponds to 1.28 seconds worth of data at the full 100 MHz sample rate. At lower sample rates you can store proportionately larger time blocks. However, below 25 MHz sample rate, the maximum number of samples is reduced to  $64 \times 10^6$  samples, because the instrument uses more resolution to measure the reduced noise floor.

The deep capture data is primarily intended to be transferred out of the instrument and analyzed off-line. A minimal user interface is provided for debugging the data and for learning. This user interface allows you to perform a deep data capture and to send consecutive traces out of the memory to drive the instrument display. You cannot change any

measurement parameters once the capture has been performed.

The typical use of deep capture is to use normal acquisitions to set up and verify the measurement, especially the triggering conditions. Then use **Fill Capture** to fill the capture buffer with data using exact same measurement settings, but collecting a lot more data.

---

**NOTE**

Remember:

- In single sweep mode, you have to press **Fill Capture**, then **Single Sweep** to actually start the data capture.
  - To exit the display of captured data, go to the **Input/Output** key menu, and set **Data Source** to Input.
  - Transferring the deep capture data can take up to 10 minutes, even when using an optimized LAN transfer.
- 

## Channel Filter

In many analysis situations you would like to apply a channel filter to the signal before it enters the analyzer to be processed. The PSA Options 122 and 140 have dedicated DSP hardware that can apply a channel filter as the data is acquired. The instrument supports 5 filter types: Raised Cosine, Root-Raised Cosine, Nyquist, Root Nyquist, and Gaussian. For each of these filter types, you control the Alpha and the Filter Bandwidth.

The filter bandwidth is set as a fraction of the current sample rate. The full 80 MHz span (Opt 122) or 40 MHz span (Opt 140) has a 100 MHz or 50 MHz sample rate, respectively. So, for example, a 20 MHz span is 1/4 of the 80 MHz span and the resulting sample rate is 25 MHz. To set up a filter 8 MHz wide in this 20 MHz span, you select a filter bandwidth of  $8/25 = 0.32$ . The channel filter bandwidth should not be set above about 0.60 to avoid interference from the measurement filter.

The channel filter is easy to use in the Waveform measurement because you can set the sample rate directly. It is more difficult to use the channel filter in the Spectrum measurement because the sample rate is limited to 100 MHz divided by powers of two ( $2^x$ ). It may not be easy to tell what the sample rate is, and it may not be what you want.

## Available Dynamic Range

The highest and lowest signal levels that can be measured are limited by many different things. The lowest amplitude signal is limited by the system noise floor, including noise in the device under test and the spectrum analyzer itself. When using the Option 122 or 140 wideband IF path, the ADC hardware clipping limits the maximum amplitude that can be measured. When the signal level exceeds the ADC clipping level an overload error will be displayed.



The analyzer amplitude response varies depending on the hardware frequency bands in your span and the center frequency. These internal amplitude variations result in changes to the ADC overload point. You may be able to increase the available measurement range for your particular measurement by experimenting with different instrument center frequency and span settings.

Option 123 lets you bypass the internal preselector. Bypassing the preselector results in more system conversion loss which lowers the overload point and further reduces the available dynamic range. If you need more dynamic range, you may want to turn the preselector back on.

## Other Sources of Measurement Information

Additional measurement application information is available through your local Agilent Technologies sales and service office. The following application notes treat digital communications measurements in much greater detail than discussed in this measurement guide.

- Application Note 1298  
Digital Modulation in Communications Systems - An Introduction  
Agilent part number 5965-7160E
- Application Note 1311  
Understanding CDMA Measurements for Base Stations and Their Components  
Agilent part number 5968-0953E

### Instrument Updates at [www.agilent.com](http://www.agilent.com)

This web location can be used to access the latest information about the instrument, including the latest firmware version.

<http://www.agilent.com/find/psa>

---

---

# 6

## Menu Maps

These menu maps are in alphabetical order by the front panel key label or oval cross-reference label. You can locate detailed information about each key/function at the page number listed in the figure title for each menu.

---

## Basic Measurement Key Flow

The key flow diagrams, shown in a hierarchical manner on the following pages, will help you grasp the overall functional relationships for the front-panel keys and the softkeys displayed at the extreme right side of the screen. The diagrams are:

“Mode Setup Key Flow” on page 253

“FREQUENCY, SPAN, AMPLITUDE & Meas Control Flows” on page 254

“Spectrum (Freq Domain) Measurement Key Flow (1 of 4)” on page 255

“Waveform (Time Domain) Measurement Key Flow (1 of 3)” on page 259

Use these flow diagrams as follows:

- There are some basic conventions:

Meas Setup

An oval represents one of the front-panel keys.

I/Q Error (Quad View)

This box represents one of the softkeys displayed.

<Bot for EVM>

This represents an explanatory description on its specific key.

Avg Number 20 On|Off

This box represents one of the default condition softkeys displayed. Default conditions are shown as much as possible with underlined parameters or values displayed on those softkey labels.

- Follow the measurement diagram from left to right and top to bottom.
- A single softkey may allow multiple choices. For example; the **Device** softkey reveals two choices, **Base** or **Mobile**. The underlined choice is the current state of the instrument. To change choices, press the softkey one time.
- When entering a numeric value of **FREQUENCY**, for example, use the numeric keypad and terminate the entry with the appropriate unit selection from the softkeys displayed.
- When entering a numeric value of **Slot (Std)**, for example, use the numeric keypad and terminate with the **Enter** front-panel key.
- Instead of using the numeric keypad to enter a value, it may be easier to use the RPG knob or **Up/Down** keys.

Figure 6-1 Mode Setup Key Flow

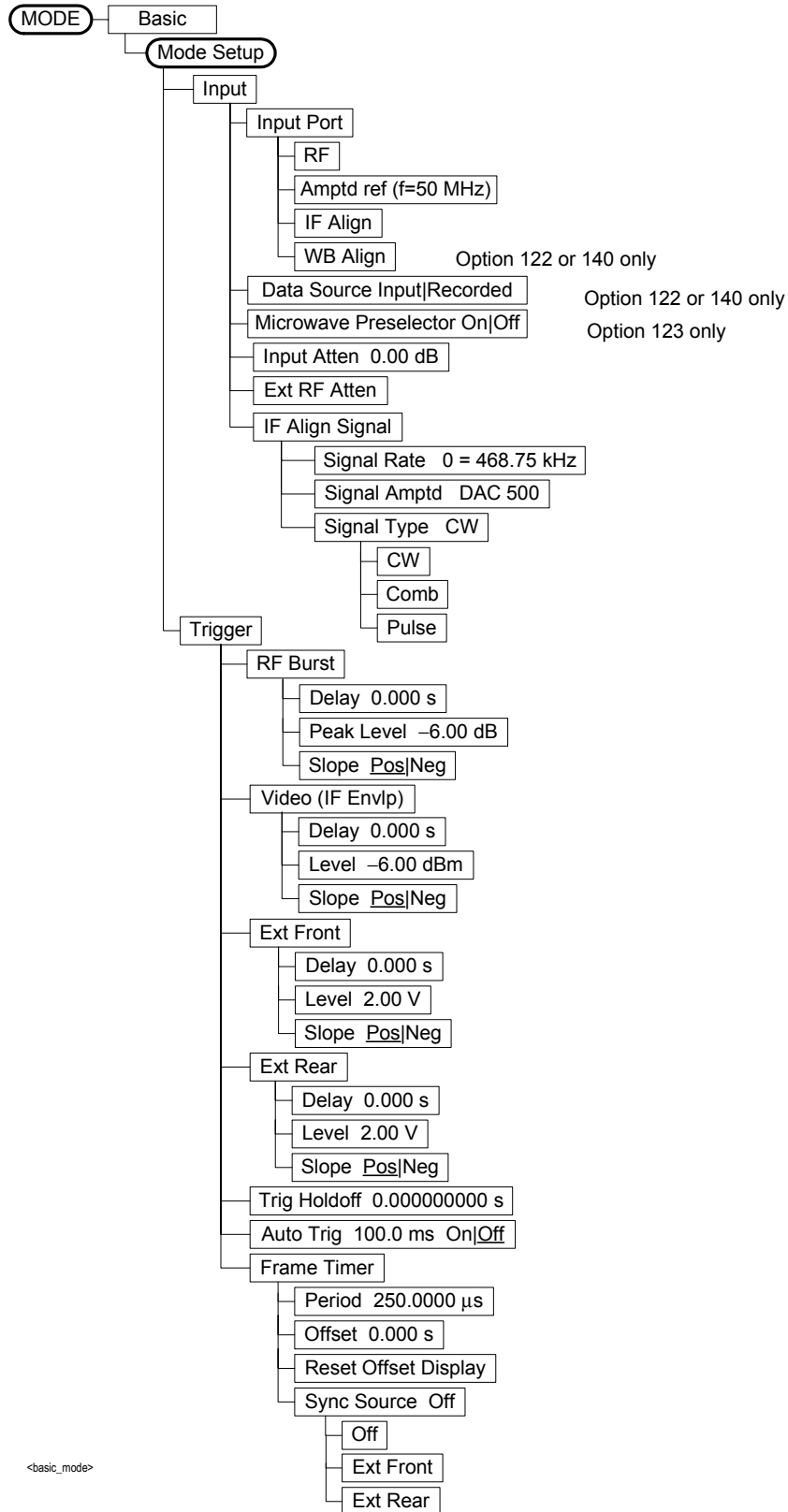
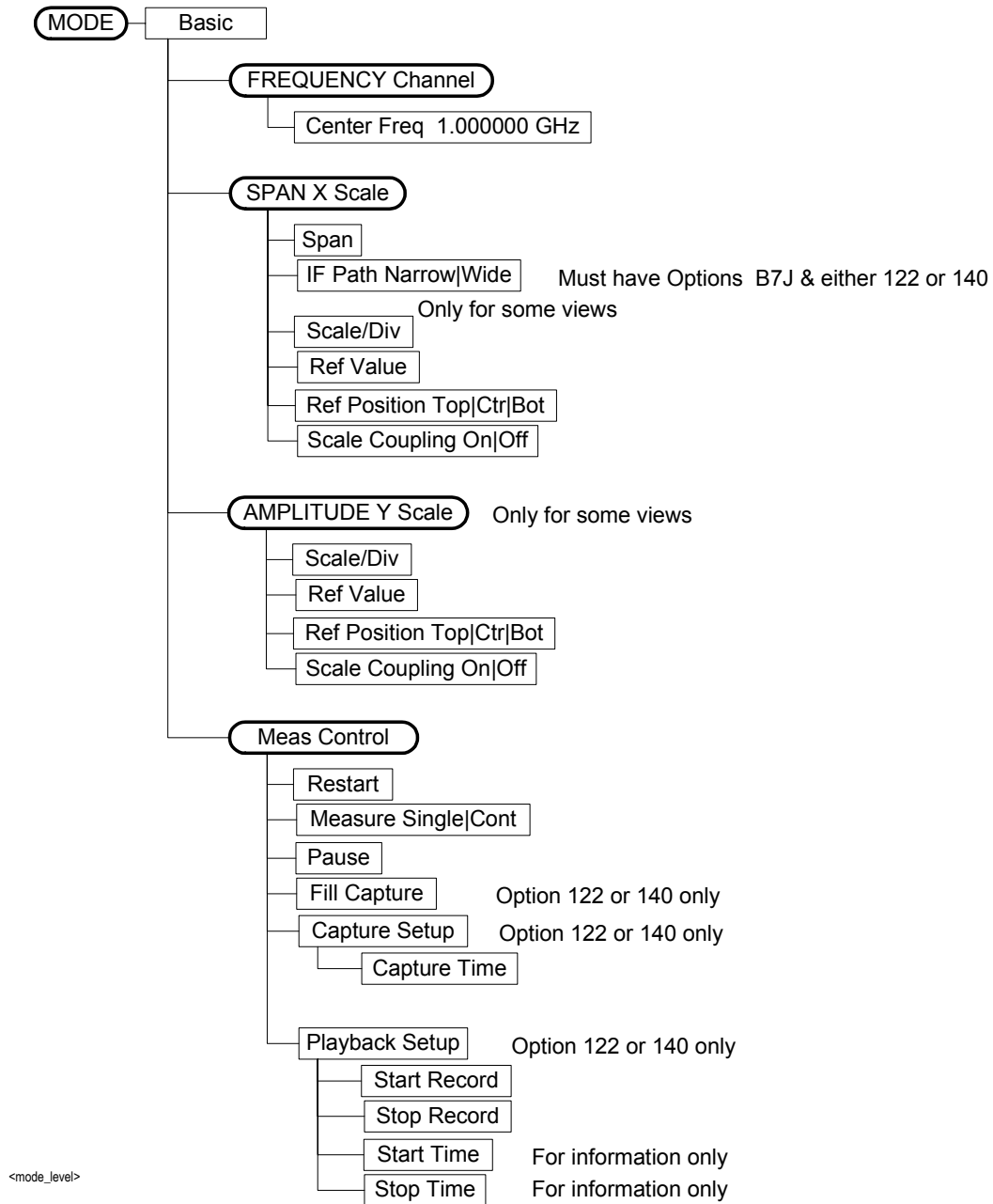

Figure 6-2 FREQUENCY, SPAN, AMPLITUDE & Meas Control Flows



**Figure 6-3 Spectrum (Freq Domain) Measurement Key Flow (1 of 4)**

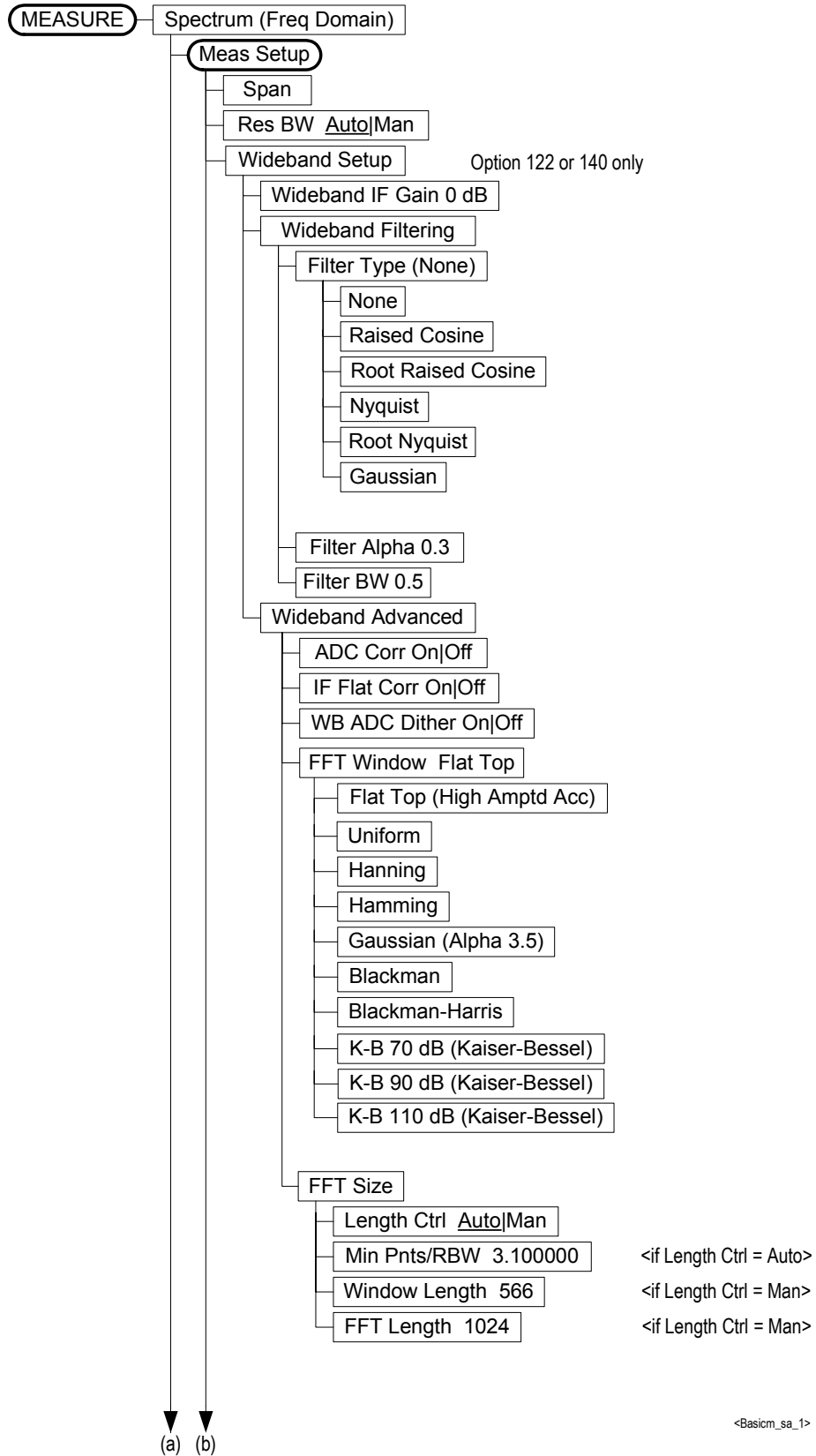
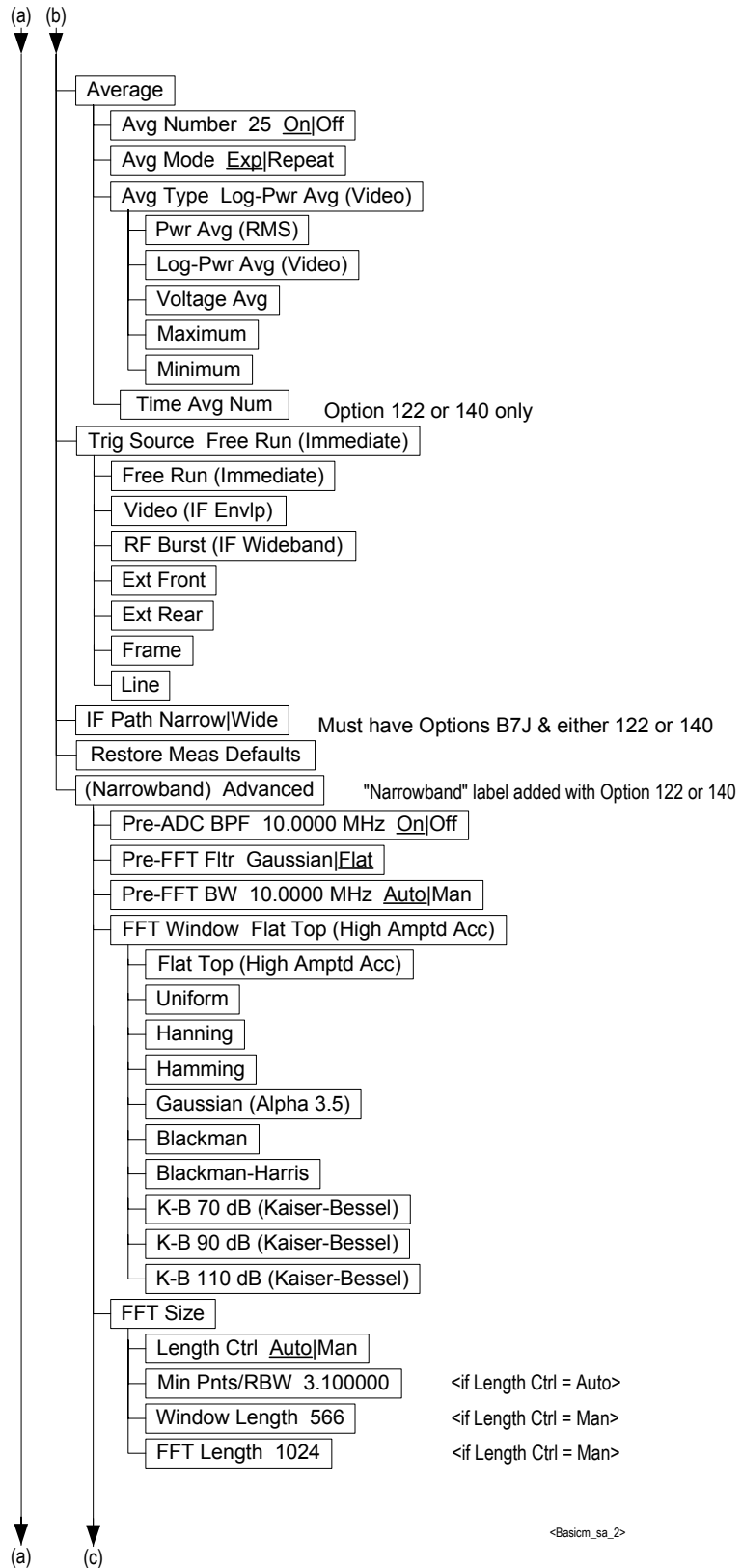

Figure 6-4 Spectrum (Freq Domain) Measurement Key Flow (2 of 4)



<Basic\_sa\_2>



Figure 6-5 Spectrum (Freq Domain) Measurement Key Flow (3 of 4)

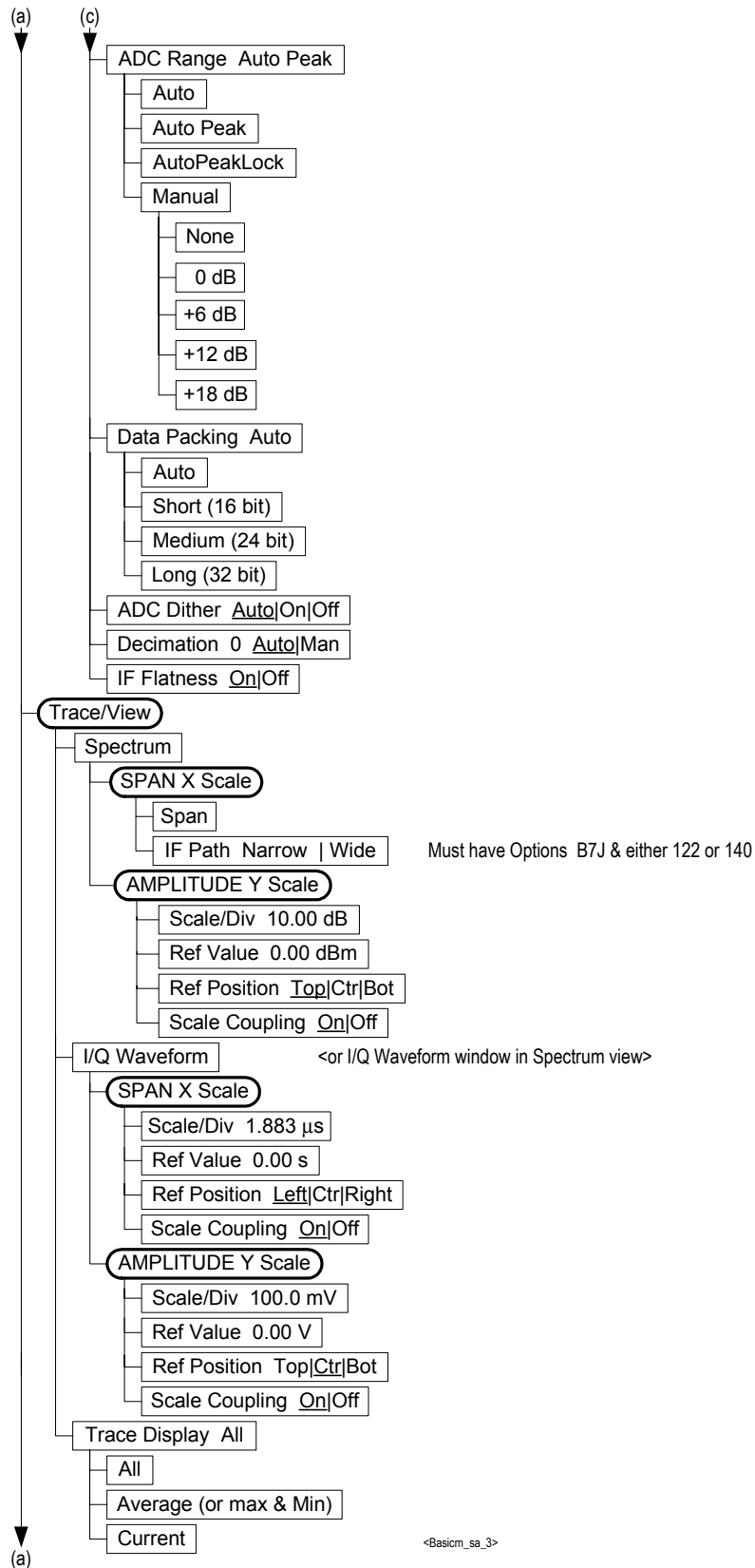

<Basicm\_sa\_3>

Figure 6-6 Spectrum (Freq Domain) Measurement Key Flow (4 of 4)

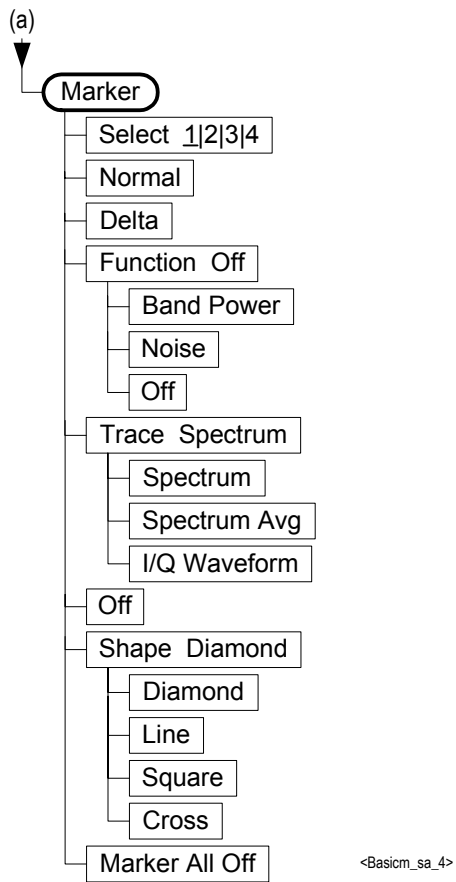

Figure 6-7 Waveform (Time Domain) Measurement Key Flow (1 of 3)

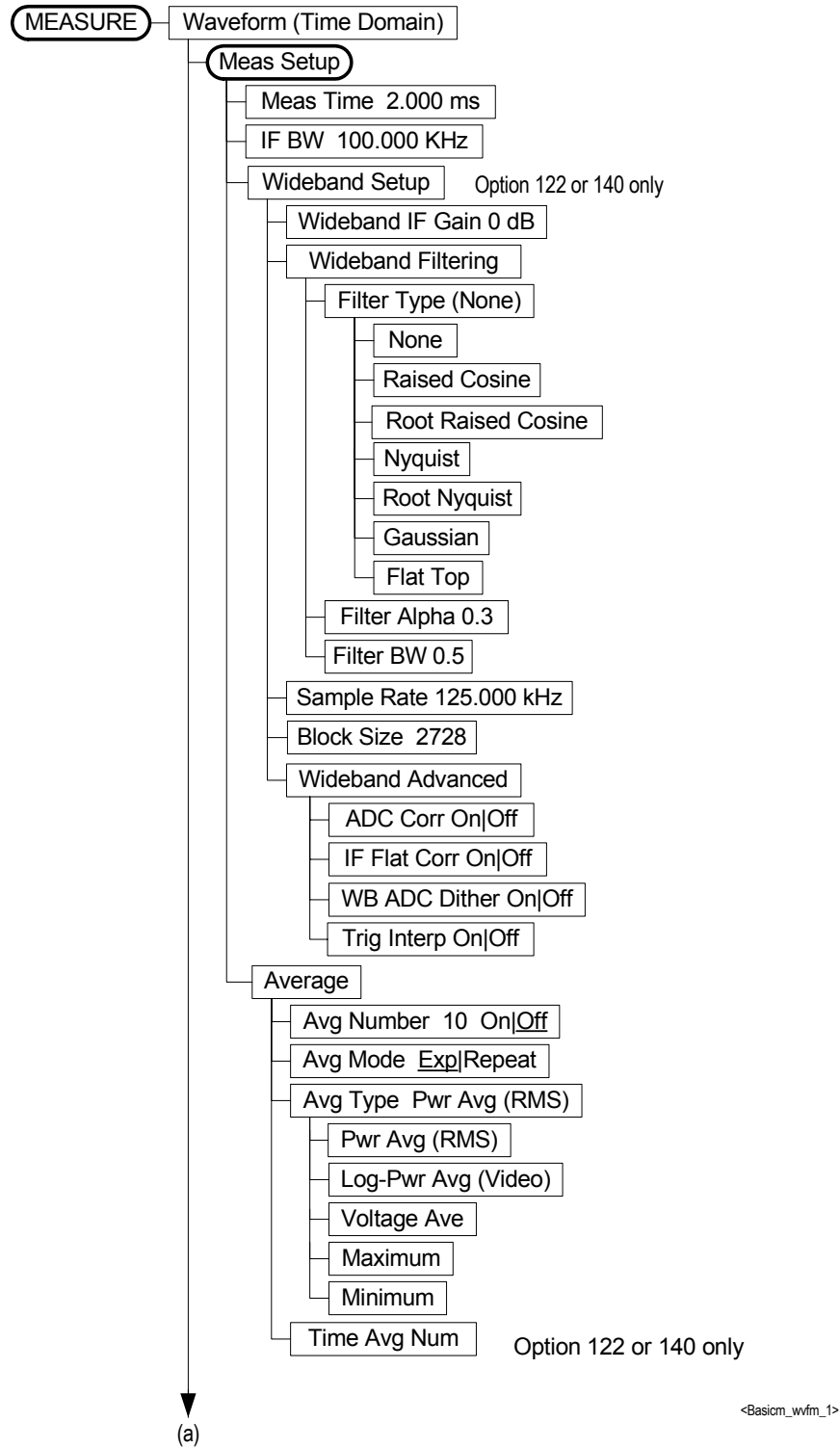

Figure 6-8 Waveform (Time Domain) Measurement Key Flow (2 of 3)

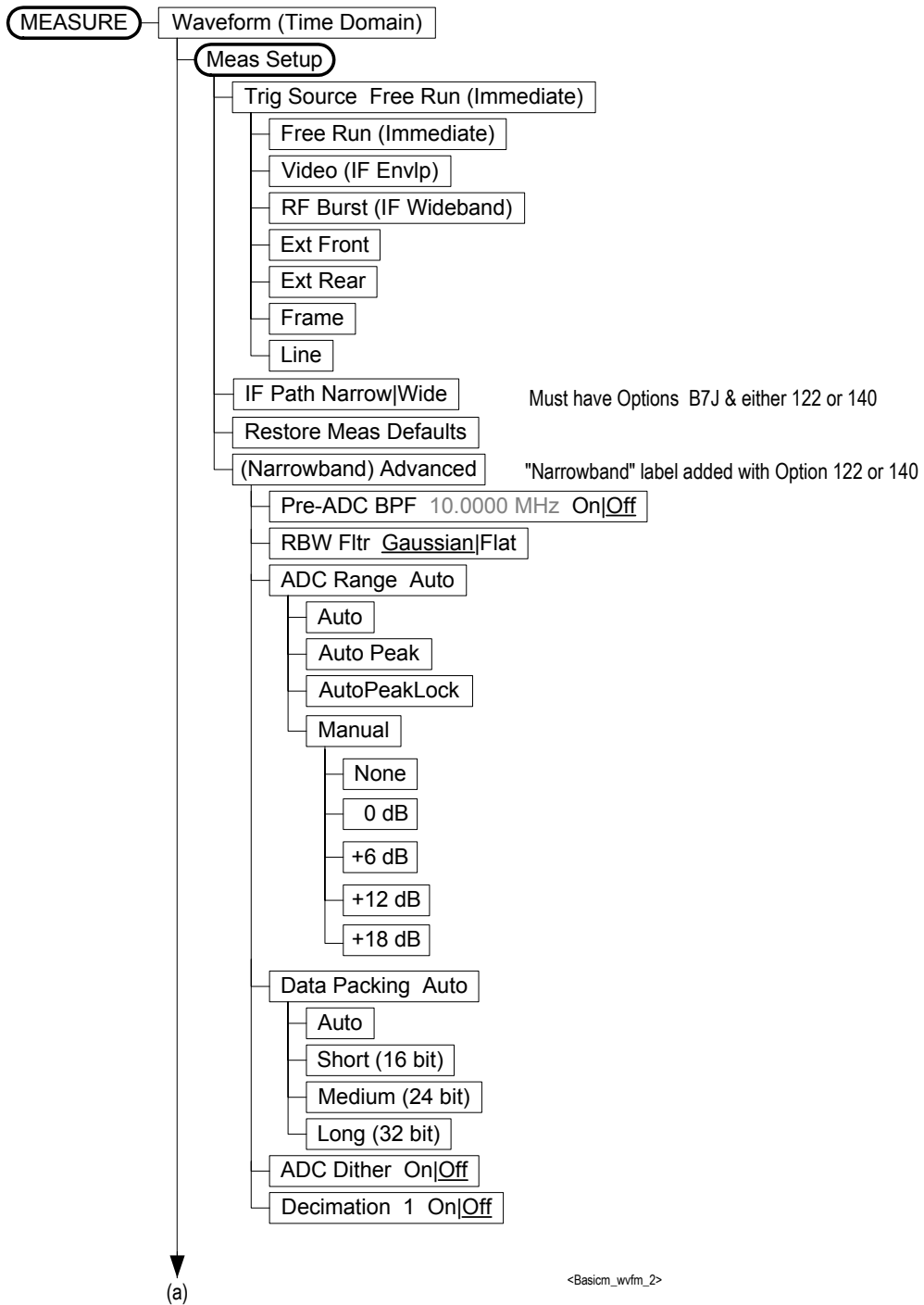

Figure 6-9 Waveform (Time Domain) Measurement Key Flow (3 of 3)

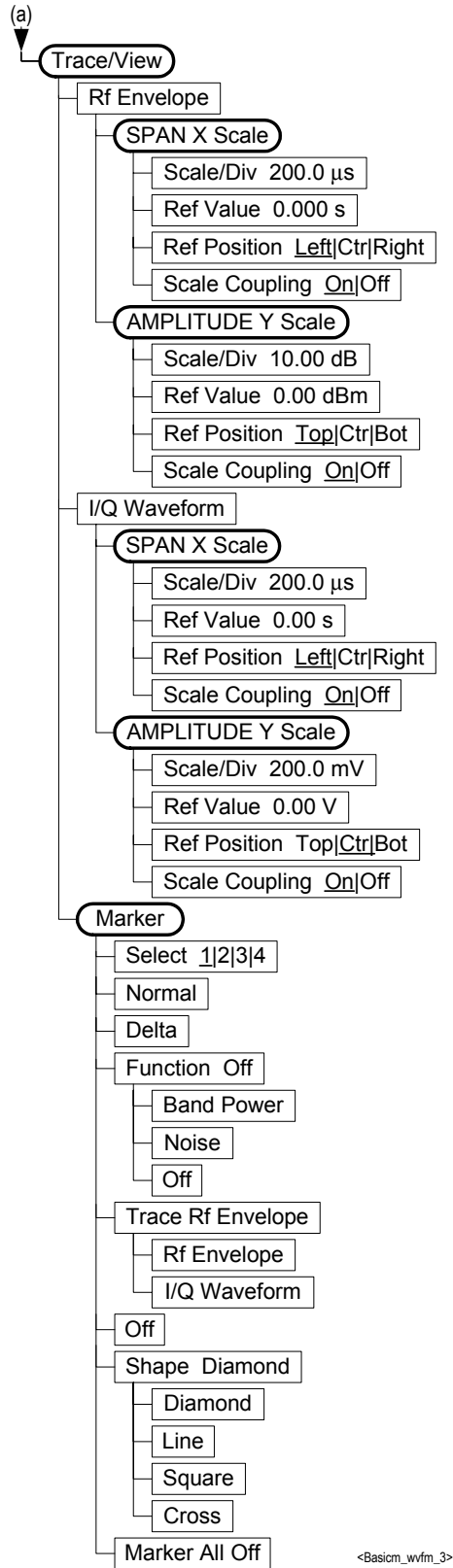

Figure 6-10 Power Stat CCDF Measurement Key Flow (1 of 3)

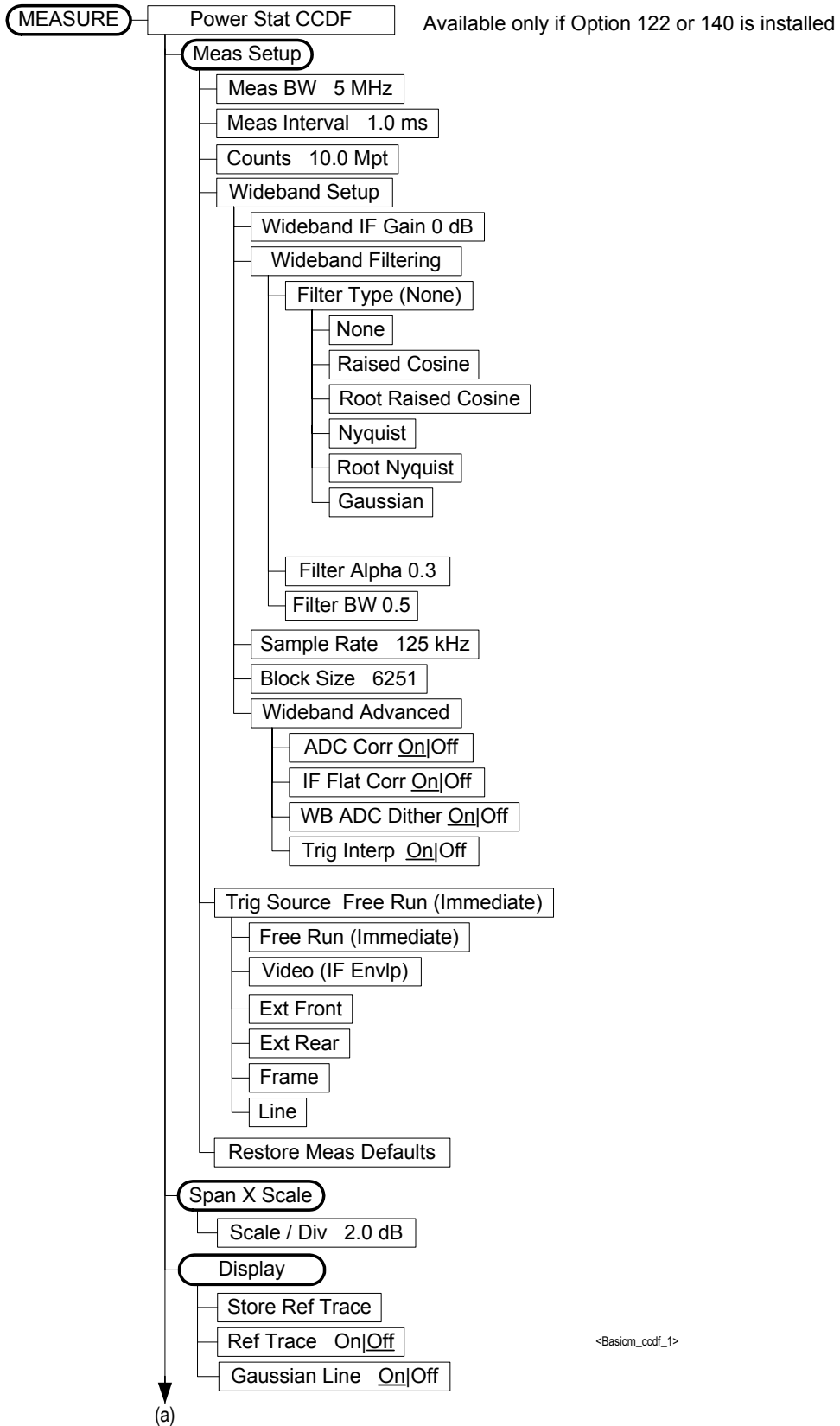
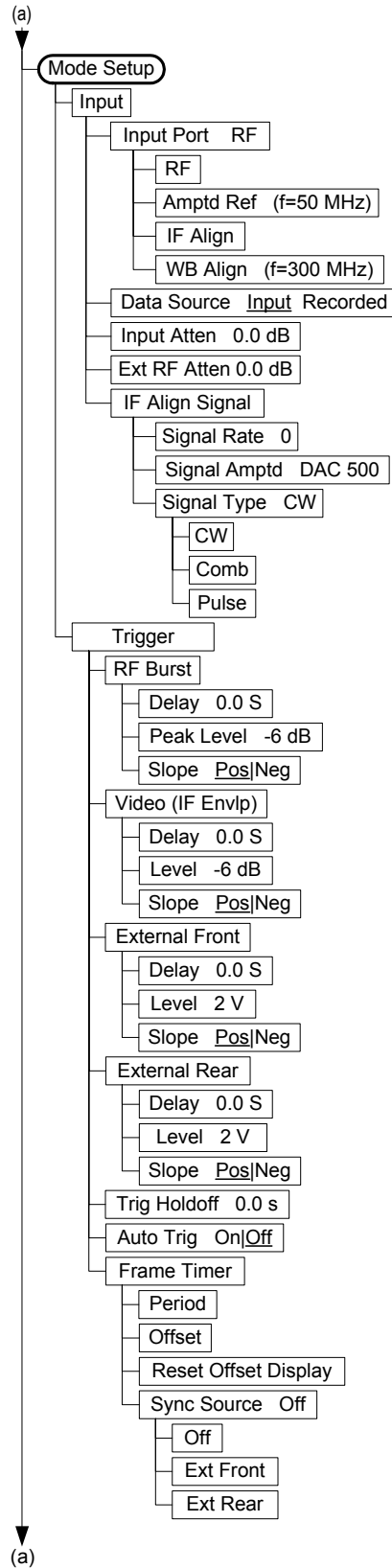
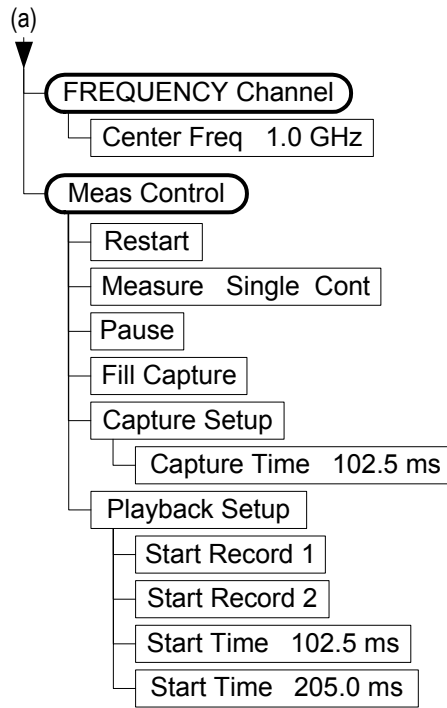

Figure 6-11 Power Stat CCDF Measurement Key Flow (2 of 3)



<Basicm\_ccdf\_2>

Figure 6-12 Power Stat CCDF Measurement Key Flow (3 of 3)



<Basim\_ccdf\_3>



**Symbols**

\*CLS, 118  
 \*ESE, 130  
 \*ESR?, 130  
 \*SRE, 127  
 \*STB?, 127

**Numerics**

122 option description, 20

**A**

acquisition packing  
   WAVEform, 218  
 active license key, 27  
   how to locate, 27  
 ADC Corr key, 82, 95, 106, 107  
 ADC corrections, CCDF, 192  
 ADC corrections, wideband IF,  
   212, 229  
 ADC Dither key  
   spectrum measurement, 87  
 ADC dither, wideband, 192  
 ADC dithering  
   SPECTrum, 197, 218  
 ADC filter  
   WAVEform, 218  
 ADC range  
   SPECTrum, 198  
   WAVEform, 219  
 ADC Range key  
   spectrum measurement, 87  
 ADC ranging function  
   automatic control, 98  
   automatic peak control, 98  
   automatic peak lock, 98  
   manual control, 99  
 adjustments  
   turning off, 58  
 Advanced menu  
   spectrum, 85  
   waveform, 98  
 advanced menu  
   ADC dither, 99  
   ADC ranging function, 98  
   decimation, 99  
   pre-ADC bandpass filter, 98  
   resolution bandwidth filter, 98  
 alignment commands, 154  
 alignment signal, 76, 77  
 alignments  
   turning off, 58  
 alpha for wideband IF filter, 189,  
   212, 214, 229, 230  
 amplitude  
   input range, 196  
   maximizing input signal, 196

Analog anti-alias filter  
   SPECTrum, 200  
   WAVEform, 220  
   WAVEform, 220  
 Analog Filter key, 82  
 applications  
   currently available, 172  
   applications, selecting, 172, 173  
 ASCII data format, 167  
 attenuation  
   setting, 195  
 automatic alignments, turning  
   off, 58  
 averaging  
   SPECTrum, 200, 201, 202  
   transmit band spurs, 220  
   WAVEform, 221, 222  
   with Option 122, 246

**B**

B7J option description, 19  
 bandwidth  
   SPECTrum, 205  
   WAVEform, 223, 224  
 bandwidth of wideband IF filter,  
   190, 214, 230  
 bandwidth, CCDF, 132, 187, 188  
 base station  
   loss correction, 194  
 Basic key, 32  
 Basic Mode functionality, 18  
 begin time capture, 171  
 binary data order, 167  
 block size, 190  
 Block Size key, 95  
 buffer  
   capture setup, 74  
   capture time, 74  
   current record, 216  
   filling it, 74  
   first record, 216  
   last record, 216  
   next record, 216  
   playback setup, 74  
   start record, 75  
   start time, 75  
   stop record, 75  
   stop time, 75  
 burst trigger  
   level, 237  
 byte order of data, 167

**C**

calibration  
   IF alignment, 76, 77  
   monitoring status of, 131  
 calibration commands, 154

capture buffer  
   current record, 216  
   filling it, 74  
   first record, 216  
   last record, 216  
   next record, 216  
   setup, 74  
 capture buffer time, 217  
 capture data  
   start, 171  
 Capture Setup key, 74  
 capture time for data buffer, 74  
 Capture Time key, 74  
 captured data block size  
   (wideband IF), 95  
 captured data sample rate  
   (wideband IF), 95  
 captured data selection, 76  
 CCDF  
   IF path, 188  
   measurement preset, 193  
   trigger interpolation, 193  
   trigger source, 193  
 CCDF block size, 190  
 CCDF IF flatness correction, 192  
 CCDF measurement, 105, 107  
   method, 242  
 CCDF sample rate, 190  
 CCDF sweep time, 188  
 CCDF WBIF ADC dither, 192  
 changing  
   instrument settings, 187  
 channel bandwidth, 132, 187, 188  
 channel filter use, 248  
 Choose Option key, 27  
 CLS command, 118  
 code, programming  
   compatibility across PSA modes,  
     111, 113  
   compatibility, PSA series versus  
     VSA, 114  
 commands  
   compatibility across PSA modes,  
     111, 113  
   CONFigure, 177  
   FETCh, 177  
   MEASure, 176  
   PSA series versus VSA  
     compatibility, 114  
   READ, 177, 178  
 compatibility, programming  
   across PSA modes, 111  
   PSA series versus VSA, 114  
 condition of instrument, 116  
 condition register, 116  
 CONFigure command use, 175  
 CONFigure commands, 177

# Index

- continuous vs. single measurement mode, 169
  - control measurement commands, 169
  - correction
    - base station loss, 194
  - correction for wideband IF filter, 212, 229
  - correction for wideband IF filter, CCDF, 192
  - corrections
    - wideband ADC corrections, 82, 95, 106, 107
  - corrections, external, 154
  - current measurement, 155
  - current measurement, query, 179
  - current time capture record, 216
  - curve fit the data, 142
- D**
- data
    - deep captures with Option 122/140, 247
    - querying, 142
  - data block size, 95
  - data buffer
    - capture setup, 74
    - capture time, 74
    - current record, 216
    - filling it, 74
    - first record, 216
    - last record, 216
    - next record, 216
    - playback setup, 74
    - start record, 75
    - start time, 75
    - stop record, 75
    - stop time, 75
  - data captures
    - acquiring deep data from Option 122, 55
  - data decimation, 206
    - WAVEform, 225
  - data format, 167
  - data from measurements, 175
  - data input selection, 195
  - Data Packing
    - spectrum measurement, 87, 99
  - data sample rate, 95
  - Data Source key, 76
  - Decimation
    - spectrum measurement, 88
  - decimation
    - SPECTrum, 206
  - decimation of data
    - WAVEform, 225
  - deep capture with Option 122/140, 247
  - default states, 33
  - default values, setting remotely, 177
  - deleting an
    - application/personality, 21
  - delta markers, 145
  - diagnostic commands, 154
  - display
    - spectrum window, 156, 157, 158, 163, 164
    - tiling, 156
    - trace, 159
    - window tile, 156
    - zoom, 157
  - display commands, 156
  - dithering the ADC, 197, 218
  - dynamic range
    - Option 122/140, 248
- E**
- enable register
    - service request, 121
  - error
    - operation status register, 131
    - questionable status register, 131
  - ESE command, 118
  - event enable register, 118
  - event register, 118
  - example
    - capture data from Option 122, 55
    - Option 122 time data, 52
  - external corrections for wideband IF, 154
  - external trigger
    - delay, 233
    - level, 233
    - Option 122, 246
    - slope, 234
- F**
- FETCh command use, 175
  - FETCh commands, 177
  - FFT
    - SPECTrum, 206, 207, 208
  - FFT bandwidth, SPECTrum, 203, 204, 215
  - FFT bandwidth, WAVEform, 231
  - FFT Length key, 83, 86
  - FFT Size menu, 82, 86
  - FFT Window key., 82, 86
  - Fill Buffer key, 74
  - filter
    - gain setup (wideband), 81, 94, 105, 106
    - negative transition, 117
    - positive transition, 116
    - setup (wideband), 81, 94, 105, 106
    - type (wideband), 94
  - Filter Alpha key, 81, 94, 105, 106
  - filter alpha, wideband IF, 189, 212, 214, 229, 230
  - filter bandwidth, wideband IF, 190, 214, 230
  - Filter BW key, 81, 95, 105, 106, 107
  - Filter Type key, 81, 94, 105, 106
  - filter type, wideband IF, 189, 214, 230
  - filtering
    - Option 122/140, 248
  - first time capture record, 216
  - Flat Top key, 81, 94, 105, 106
  - format, data, 167
  - frame trigger
    - Option 122, 245
    - used with Option 122, 56
  - frame trigger adjustment, 234, 235
  - frame trigger period, 234
  - frame trigger sync mode, 235
  - frequency channel
    - center frequency, 72
  - frequency channel key menu, 72
  - frequency span
    - SPECTrum, 209
- G**
- Gaussian key, 81, 94, 105, 106
  - Gaussian line, CCDF, 187
- H**
- hardware
    - monitoring status of, 131
  - hardware data averaging with Option 122, 246
  - hardware status, 116
  - hardware time averaging with Option 122, 56
  - holdoff of trigger with Option 122, 244
- I**
- I or Q waveform window
    - span X scale
      - reference position, 73, 91, 103
      - reference value, 72, 91, 103
      - scale coupling, 73, 92, 103

- scale per division, [72](#), [91](#), [102](#)
  - I/Q data results, [180](#), [182](#), [185](#)
  - I/Q waveform window, [102](#), [103](#)
  - IF Align key, [77](#)
  - IF alignment signal, [76](#), [77](#)
  - IF BW key, [94](#)
  - IF filter
    - gain setup, [81](#), [94](#), [105](#), [106](#)
    - setup, [94](#)
    - type, [94](#)
  - IF Flat Corr key, [82](#), [95](#), [106](#), [107](#)
  - IF Flatness
    - advanced spectrum feature, [88](#)
  - IF flatness correction, [192](#)
  - IF path
    - CCDF, [188](#)
    - SPECTrum, [210](#)
    - WAVEform, [225](#), [226](#)
  - IF path filter
    - alpha, [81](#), [94](#), [105](#), [106](#)
    - bandwidth, [81](#), [95](#), [105](#), [106](#), [107](#)
    - setup, [81](#), [105](#), [106](#)
    - type, [81](#), [105](#), [106](#)
  - IF Path key, [85](#), [98](#)
  - IF setup, [81](#), [94](#), [105](#), [106](#)
  - IF trigger delay, [236](#)
  - IF trigger level, [236](#)
  - IF trigger slope, [237](#)
  - improve speed of Waveform measurement, [226](#)
  - improving dynamic range with
    - Option 122 or 140, [248](#)
  - initial signal connection, [33](#)
  - initiate measurement, [169](#), [170](#)
  - input
    - external attenuator, [77](#)
    - IF alignment signal
      - signal amplitude, [77](#)
      - signal rate, [77](#)
      - signal type, [77](#)
    - input attenuator, [76](#)
    - input port
      - rf, [76](#)
  - input attenuation, [195](#)
  - input key menu, [76](#)
  - input port
    - 50 MHz reference, [76](#)
    - IF align, [76](#)
  - input port selection, [194](#), [195](#)
  - input power
    - maximum, [196](#)
    - range, [196](#)
  - input selection, [195](#)
  - input/output
    - playback setup, [74](#)
    - playback start record, [75](#)
    - playback start time, [75](#)
    - playback stop record, [75](#)
    - playback stop time, [75](#)
    - wideband IF alignment, [76](#), [77](#)
  - Install Now key, [27](#)
  - Installing and Obtaining a license key, [27](#)
  - installing measurement personalities, [21](#)
  - instrument configuration, [172](#)
  - instrument status, [116](#)
  - internal reference selection, [194](#), [195](#)
  - IQ data, programming acquisition of, [60](#)
  - IQ input selection, [194](#)
  - IQ port selection, [194](#), [195](#)
- L**
- large data captures with Option 122/140, [247](#)
  - last time capture record, [216](#)
  - Length Ctrl key, [82](#), [86](#)
  - Length key, [82](#), [86](#)
  - license key
    - obtaining and installing, [27](#)
  - limit line testing, [179](#)
  - line trigger
    - Option 122, [246](#)
  - linear envelope window, [102](#), [103](#)
  - linear spectrum window
    - amplitude Y scale
      - reference position, [92](#)
      - reference value, [92](#)
      - scale coupling, [92](#)
      - scale per division, [92](#)
    - span, [72](#), [91](#)
  - loading an application/personality, [21](#)
- M**
- major functional keys, [70](#)
  - making basic measurements, [32](#)
  - making measurements, [175](#)
  - markers, [143](#)
    - assigning them to traces, [147](#)
    - maximum, [144](#)
    - minimum, [145](#)
    - off, [147](#)
    - trace assignment, [151](#), [152](#)
    - turn off, [144](#)
    - type, [145](#)
    - valid measurement, [143](#)
    - value, [152](#)
    - value of, [144](#)
    - x-axis location, [151](#), [152](#)
    - y-axis, [152](#)
  - maximum value of trace data, [142](#)
  - mean value of trace data, [142](#)
  - meas BW, [132](#), [187](#), [188](#)
  - meas BW key
    - power stat CCDF measurement, [105](#)
  - meas interval key
    - power stat CCDF measurement, [105](#)
  - Meas Time key, [94](#)
  - MEASure command use, [175](#)
  - MEASure commands, [176](#)
  - measure setup
    - restore measurement defaults, [85](#), [98](#), [108](#)
  - measurement
    - markers, [143](#)
    - power stat, [187](#)
    - power statistics CCDF, [180](#)
    - query current, [155](#)
    - spectrum (frequency domain), [197](#)
    - waveform (time domain), [218](#)
  - measurement control
    - capture setup, [74](#)
    - capture time, [74](#)
    - fill buffer, [74](#)
    - measure, [74](#)
    - pause, [74](#)
    - restart, [73](#)
  - measurement errors
    - monitoring status of, [131](#)
  - measurement jitter, using frame trigger, [245](#)
  - measurement modes
    - currently available, [172](#)
    - selecting, [172](#), [173](#)
  - measurement preset
    - CCDF, [193](#)
  - measurement range maximum
    - with Option 122/140, [248](#)
  - measurement selection
    - spectrum (frequency domain), [73](#)
    - waveform (time domain), [73](#)
  - measurement setup
    - averaging mode, [83](#), [95](#)
      - exponential, [83](#), [96](#)
    - averaging number, [83](#), [95](#)
    - averaging type, [84](#), [96](#)
      - log power average (video), [84](#), [96](#)
      - maximum voltage average, [84](#), [96](#)
      - minimum voltage average, [84](#), [96](#)
      - power average (rms), [84](#), [96](#)

# Index

- voltage average, [84, 96](#)
  - time averaging number, [84](#)
  - measurement time, time capture, [217](#)
  - measurements
    - basic, [32](#)
    - CONF/FETC/MEAS/READ commands, [175](#)
    - control of, [169](#)
    - getting results, [175](#)
    - how to make, [32](#)
    - query current, [179](#)
    - setting default values remotely, [177](#)
    - single/continuous, [169](#)
    - spectrum (frequency domain), [182](#)
    - waveform (time domain), [185](#)
  - measuring I/Q data, [180, 182, 185](#)
  - measuring in the time domain, [48](#)
  - Min Pts in RBW key, [82, 86](#)
  - minimum value of trace data, [142](#)
  - missing options, [21](#)
  - mode
    - basic, [32](#)
  - Modulation Accuracy key
    - View/Trace key, [51](#)
  - monitoring instrument
    - conditions, [131](#)
  - monitoring the instrument, [116](#)
- N**
- negative transition filter, [117](#)
  - next time capture record, [216](#)
  - noise reduction with Option 122, [56](#)
    - Option 122 noise reduction, [246](#)
  - normal marker, [145](#)
- O**
- OPC command, [118](#)
  - operation status register, [131](#)
  - Option 122
    - acquiring time data, [52](#)
    - external trigger, [246](#)
    - frame trigger, [245](#)
    - hardware averaging, [246](#)
    - line trigger, [246](#)
    - making deep captures, [55](#)
    - noise reduction, [56](#)
    - trigger holdoff, [244](#)
    - using frame trigger, [56](#)
    - video trigger, [244](#)
  - Option 122 deep data capture, [55](#)
  - Option 122 description, [20](#)
  - Option 122 programming control, [52](#)
  - Option 122 programming
    - example, [52](#)
  - Option 122 wideband selection, [85, 98](#)
  - Option 122/140
    - channel filter, [248](#)
    - deep data capture, [247](#)
    - dynamic range, [248](#)
    - trigger system differences, [243](#)
  - Option B7J description, [19](#)
  - options
    - loading/deleting, [21](#)
  - Options 122 and 140 description, [243](#)
  - options not in instrument
    - memory, [21](#)
  - overload error using Option 122/140, [248](#)
- P**
- packing
    - SPECTrum, [197](#)
  - pass/fail test, [179](#)
  - personalities
    - currently available, [172](#)
    - selecting, [172, 173](#)
  - personality options not in instrument, [21](#)
  - phase window, [102, 103](#)
  - Playback Setup key, [74](#)
  - positive transition filter, [116](#)
  - power stat, [188, 190](#)
  - power stat CCDF, [187, 188, 190, 192](#)
  - Power Stat CCDF key, [242](#)
  - Power stat CCDF measurement, [49](#)
  - power stat CCDF measurement
    - power stat measurement, [187](#)
    - power statistics, [188, 190, 192](#)
      - measurement preset, [193](#)
      - trigger interpolation, [193](#)
      - trigger source, [193](#)
    - power statistics CCDF measurement, [180](#)
  - Power Statistics CCDF Result - Basic Mode, [50](#)
  - pre-ADC bandpass filter
    - SPECTrum, [204](#)
  - Pre-ADC BPF key
    - spectrum measurement, [85](#)
  - pre-FFT bandwidth, SPECTrum, [203, 204, 215](#)
  - pre-FFT bandwidth, WAVEform, [231](#)
  - Pre-FFT BW key, [86](#)
  - Pre-FFT Fltr key, [86](#)
  - pre-recorded data selection, [195](#)
  - preset, [33](#)
    - factory defaults, [33](#)
    - preset states, [33](#)
  - printing
    - monitoring status of, [131](#)
  - procedure
    - using the waveform measurement, [48](#)
  - programming
    - compatibility among PSA modes, [111, 113](#)
    - compatibility, PSA series versus VSA, [114](#)
  - programming control of Option 122, [52](#)
  - programming example
    - Option 122, [60](#)
    - Option 122 deep data capture, [55](#)
    - Option 122 noise reduction, [56](#)
    - Option 122 time data, [52](#)
    - using Option 122, [52](#)
  - PSA series versus VSA (programming compatibility), [114](#)
- Q**
- query data, [142](#)
  - questionable status register, [131](#)
- R**
- Raised Cosine Key, [81, 94, 105, 106](#)
  - READ command use, [175](#)
  - READ commands, [177, 178](#)
  - real number data format, [167](#)
  - rear panel external trigger
    - delay, [233](#)
    - slope, [234](#)
  - recorded data selection, [195](#)
  - reference, selecting internal, [194, 195](#)
  - registers, [121](#)
    - condition, [116](#)
    - event, [118](#)
    - event enable, [118](#)
    - operation, [131](#)
    - questionable, [131](#)
    - service request enable, [128](#)
    - standard event status, [129](#)
    - status byte, [127](#)
  - Res BW key

- spectrum measurement, [81](#)
- waveform measurement, [94](#)
- restart measurement, [171](#)
- results, waveform measurement, [241](#)
- return data, [142](#)
- RF input selection, [194](#)
- RF input, selection, [194](#), [195](#)
- RMS of trace data, [142](#)
- Root Nyquist key, [81](#), [94](#), [105](#), [106](#)
- RRC (root raised cosine) key, [81](#), [94](#), [105](#), [106](#)
- S**
- sample rate for wideband IF, [226](#)
- Sample Rate key, [95](#)
- sample rate, CCDF measurement, [105](#), [107](#)
- sampling trace data, [142](#)
- SCPI programming examples, [52](#)
- select captured data, [76](#)
- selecting the
  - wideband/narrowband path, [85](#), [98](#)
- service request enable register, [121](#), [128](#)
- service requests, [116](#), [121](#)
- set up the wideband IF, [81](#), [94](#), [105](#), [106](#)
- signal envelope window, [102](#), [103](#)
  - amplitude Y scale
    - reference position, [103](#)
    - reference value, [103](#)
    - scale coupling, [103](#)
    - scale per division, [103](#)
- single vs. continuous
  - measurement mode, [169](#)
- Socket LAN programming
  - example, [60](#)
- span
  - selecting IF path, [85](#), [98](#)
  - SPECTrum, [209](#)
- Span key
  - spectrum measurement, [81](#)
- SPECTrum
  - acquisition packing, [197](#)
  - ADC range, [198](#)
  - Analog anti-alias filter, [200](#)
  - data decimation, [206](#)
  - FFT length, [206](#), [207](#)
  - FFT resolution BW, [207](#)
  - FFT window, [208](#)
  - FFT window delay, [208](#)
  - frequency span, [209](#)
  - IF path, [210](#)
  - sweep time, [210](#), [211](#)
  - trigger source, [211](#)
- spectrum
  - all traces, [91](#), [102](#)
  - averaged trace, [91](#), [102](#)
  - changing views, [37](#), [90](#)
  - current trace, [91](#), [102](#)
  - next window selection, [90](#)
  - span X scale, [72](#), [91](#)
  - trace display, [91](#), [102](#)
  - view/trace, [37](#), [90](#)
  - zoom a window, [90](#)
- Spectrum (Frequency Domain)
  - key, [81](#), [105](#), [240](#)
- spectrum (frequency domain)
  - measurement, [182](#), [197](#)
  - See also SPECTrum
- Spectrum measurement
  - Waveform measurement, [18](#)
- spectrum measurement
  - method, [240](#)
  - results, [36](#), [90](#)
- spectrum measurement display, [156](#), [157](#), [158](#), [163](#), [164](#)
- speed up the Waveform
  - measurement, [226](#)
- SRE command, [118](#)
- SRQ, [116](#)
- SRQ command, [121](#)
- standard deviation of trace data, [142](#)
- standard event status, [129](#)
  - enable register, [130](#)
- start a time capture, [171](#)
- start measurement, [169](#), [170](#), [171](#)
- start record, [216](#)
- start record for capture data
  - buffer, [75](#)
- Start Record key, [75](#)
- start time for capture data buffer, [75](#)
- Start Time key, [75](#)
- state
  - changing, [187](#)
- status byte
  - register system, [116](#), [123](#), [124](#), [125](#)
- status byte register, [126](#)
- status enable register, [130](#)
- status register
  - operation status, [131](#)
  - questionable status, [131](#)
- status registers, [123](#), [124](#), [125](#)
  - operation, [131](#)
  - questionable, [131](#)
  - setting and querying, [118](#)
- STB command, [118](#)
- stop record for capture data
  - buffer, [75](#)
- Stop Record key, [75](#)
- stop time for capture data buffer, [75](#)
- Stop Time key, [75](#)
- stop trace calculations, [226](#)
- stored data selection, [76](#)
- sweep
  - monitoring status of, [131](#)
- sweep time, [188](#)
  - SPECTrum, [210](#), [211](#)
  - WAVEform, [227](#)
- Sweep Time key, [94](#)
- T**
- test limits, [179](#)
- tile the display, [156](#)
- time averaging, [84](#)
- time averaging with Option 122, [56](#)
- time capture
  - current record, [216](#)
  - first record, [216](#)
  - last record, [216](#)
  - measurement time, [217](#)
  - next record, [216](#)
  - start, [171](#)
- time data
  - acquiring it from Option 122, [52](#)
- time domain measurement, [18](#), [185](#), [218](#)
- time domain measurements, [94](#), [241](#)
- time length for data buffer, [74](#)
- trace data
  - processing, [142](#)
- trace display, [159](#)
- trace format, [167](#)
- trace names for markers, [147](#)
- trace/view selection
  - magnitude & phase graph view, [44](#), [101](#)
- transmit band spurs - averaging
  - state, [220](#)
- trig interp key, [106](#), [107](#)
- trigger
  - auto time, [232](#)
  - automatic trigger, [78](#)
  - burst level, [237](#)
  - CCDF, [193](#)
  - commands, [232](#)
  - delay, [78](#), [233](#)
  - delay, IF, [236](#)
  - external, [233](#), [234](#)
  - external front input, [78](#)
  - external rear input, [78](#)

# Index

- frame adjustment, 234, 235
  - frame period, 234
  - frame sync mode, 235
  - frame timer, 79
    - offset, 79
    - period, 79
    - reset offset display, 79
    - synchronizing source, 79
  - holdoff, 236
  - level, 78, 233
  - level, IF, 236
  - monitoring status of, 131
  - on/off, 232
  - Option 122/140 operation, 243
  - RF burst signal, 78
  - slope, 78, 234
  - slope, IF, 237
  - SPECTrum, 211
  - timeout, 232
  - trigger holdoff, 78
  - trigger source, 84, 97, 107
    - external front input, 85, 97, 108
    - external rear input, 85, 97, 108
    - frame clock, 85, 97, 108
    - free run (immediate), 84, 97, 107
    - line, 85, 97, 108
    - RF burst (wideband), 84, 97
    - video (IF envelope), 84, 97, 107
    - video (envelope) signal, 78
  - WAVEform, 228
  - trigger error offset
    - WAVEform, 227
  - trigger holdoff
    - Option 122, 244
  - trigger interpolation function, CCDF, 106, 107
  - trigger measurement, 169, 170
  - triggering setup help, waveform measurement, 48
  - turning alignments off, 58
- U**
- Uninstall Now, 29
  - uninstalling measurement personalities, 21
  - unlocked hardware
    - monitoring status of, 131
- V**
- video trigger
    - Option 122, 244
  - view commands, 156
  - view/trace
    - spectrum graph, 37, 90
  - View/Trace key
    - Modulation Accuracy key, 51
  - view/trace selection
    - I/Q waveform graph window, 37
    - Spectrum I/Q Waveform view, 37
  - viewing the time domain, 48
  - VISA COM use with Visual Basic, 60
  - Visual Basic example using Opt 122, 60
  - VSA versus PSA series (programming compatibility), 114
- W**
- WAVEform
    - Analog anti-alias filter, 220
  - WAVEform
    - acquisition packing, 218
    - ADC filter, 218
    - ADC range, 219
    - Analog anti-alias filter, 220
    - data decimation, 225
    - IF path, 225, 226
    - sweep time, 227
    - trigger error offset, 227
    - trigger interpolation, 228
    - trigger source, 228
  - waveform
    - advanced settings, 98
    - changing displays, 102
    - method, 241
    - resolution bandwidth, 94
    - results, 43
    - span X scale, 102
    - sweep time, 102
    - using markers, 104
  - Waveform (Time Domain) key, 241
  - Waveform (Time Domain) Key Menus, 94
  - waveform (time domain) measurement, 185, 218
    - See also WAVEform
  - waveform measurement, 48, 94
    - display, 103
    - results, 43
  - WB ADC Dither key, 82, 95, 106, 107
  - WBIF Align (f=30MHz) key, 76
  - Wideband Advanced key, 81, 95, 106, 107
  - wideband digitizer programming example, 52
  - wideband filter alpha, 81, 94, 105, 106
  - wideband filter bandwidth, 81, 95, 105, 106, 107
  - wideband filter type, 94
  - Wideband Filtering key, 81, 94, 105, 106
  - wideband IF
    - advanced settings, 82, 95, 106, 107
    - sample rate, 226
  - wideband IF alignment signal, 76, 77
  - wideband IF data block size, 95
  - wideband IF data sample rate, 95
  - wideband IF external corrections, 154
  - wideband IF filter ADC correction, 192
  - wideband IF filter ADC corrections, 212, 229
  - wideband IF filter alpha, 189, 212, 214, 229, 230
  - wideband IF filter bandwidth, 190, 214, 230
  - wideband IF filter type, 81, 105, 106, 189, 214, 230
  - Wideband IF Gain key, 81, 94, 105, 106
  - Wideband IF Setup key, 81, 94, 105, 106
  - wideband input path, 210, 225, 226
  - wideband input path, CCDF, 188
  - wideband path hardware averaging, 246
  - wideband path selection, 85, 98
  - wideband path trigger operation, 243
  - Window Length key, 82, 86
- Z**
- zero span measurement, 185, 218
  - zoom the display, 157