

## Agilent E5071C Network Analyzer

- 9 kHz to 4.5/6.5/8.5 GHz
- 100 kHz to 4.5/6.5/8.5 GHz (with bias tees)
- 300 kHz to 14/20 GHz (with bias tees)

## E5092A Configurable Multiport Test Set

### Configuration Guide



This configuration guide describes standard configurations, options, accessories and peripherals for the E5071C ENA network analyzer. Refer to the ENA brochure for a complete description of the ENA network analyzer and the E5092A configurable multiport test set.



## E5071C ENA Network Analyzer

The ENA is an integrated network analyzer with a two- or four-port S-parameter test set, a synthesized RF source, a 10.4-inch color LCD, and a hard disk drive. A 1-year return-to-Agilent service warranty is included with the each ENA network analyzer.

### Step 1: Select frequency range, number of test ports, and with or without bias tees

#### Up to 4.5 GHz range

9 kHz to 4.5 GHz (without bias tees)

**E5071C-240** 2-port S-parameter test set

**E5071C-440** 4-port S-parameter test set

100 kHz to 4.5 GHz (with bias tees)

**E5071C-245** 2-port S-parameter test set

**E5071C-445** 4-port S-parameter test set

#### Up to 6.5 GHz range

9 kHz to 6.5 GHz (without bias tees)

**E5071C-260** 2-port S-parameter test set

**E5071C-460** 4-port S-parameter test set

100 kHz to 6.5 GHz (with bias tees)

**E5071C-265** 2-port S-parameter test set

**E5071C-465** 4-port S-parameter test set

#### Up to 8.5 GHz range

9 kHz to 8.5 GHz (without bias tees)

**E5071C-280** 2-port S-parameter test set

**E5071C-480** 4-port S-parameter test set

100 kHz to 8.5 GHz (with bias tees)

**E5071C-285** 2-port S-parameter test set

**E5071C-485** 4-port S-parameter test set

#### Up to 14 GHz range<sup>3</sup>

300 kHz to 14 GHz (with bias tees)

**E5071C-2D5** 2-port S-parameter test set

**E5071C-4D5** 4-port S-parameter test set

#### Up to 20 GHz range<sup>3</sup>

300 kHz to 20 GHz (with bias tees)

**E5071C-2K5** 2-port S-parameter test set

**E5071C-4K5** 4-port S-parameter test set

### Step 2: Select time base

**E5071C-1E5** High stability time base

**E5071C-UNQ** Standard stability time base

### Step 3: Select hard disk drive

**E5071C-017** Removable hard disk drive

**E5071C-019** Standard hard disk drive

### Step 4: Choose additional options (Optional)

**E5071C-008<sup>1</sup>** Frequency offset mode

**E5071C-TDR<sup>2</sup>** Enhanced time domain analysis

**E5071C-010** Time domain analysis

**E5071C-790** Measurement Wizard Assistant software

### Step 5: Choose accessories (Optional)

**E5071C-1CM** Rack mount kit,

**E5071C-1CN** Front handle kit

**E5071C-1CP** Rack mount and front handle kit

**E5071C-810** Adds a keyboard

**E5071C-820** Adds a mouse

### Step 6: Choose certification documentation (Optional)

**E5071C-1A7** ISO 17025 compliant calibration

**E5071C-A6J** ANSI Z540 compliant calibration

### Step 7: Choose your warranty service (Optional)

3 year return-to Agilent warranty and service

5 year return-to Agilent warranty and service

## Documentation

The documentation for the E5071C is located in the Online Help system for the E5071C ENA network analyzer. The ENA Service Guide and Online Help system are also available on the Web site:

[www.agilent.com/find/ena](http://www.agilent.com/find/ena)

## Additional product information

For additional product information, refer to the ENA brochure available on the Web site:

[www.agilent.com/find/ena](http://www.agilent.com/find/ena)

1. Order the 82357B USB/GPIB interface at the same time if you want to control power meters with the E5071C. This will allow you to conduct scalar mixer calibrations (SMC), power calibrations, or receiver calibrations after power calibrations.
2. E5071C-TDR is a superset of E5071C-010. E5071C-TDR and E5071C-010 are mutually exclusive options and there is no need to purchase both options.
3. Consider purchasing Agilent 20mm TORQUE WRENCH 8710-1764 for NMD 3.5 mm(f) test port connector.

## E5071CEP ENA Network Analyzer – Express Configuration

The Agilent E5071CEP ENA series network analyzer express configurations are preconfigured option packages for off-the-shelf delivery from our authorized distributors. The express configurations deliver the same specifications and functionality as Agilent’s build-to-order instruments and also provide the same level of upgradeability, ensuring that they can evolve as your test needs change. For more detail, visit, [www.agilent.com/find/express-e5071c](http://www.agilent.com/find/express-e5071c)

### Model

Options	Description
E5071CEP	ENA Series Network Analyzer – Express Configuration

### Options

Options	Frequency	Connector Type	Number of Port	Bias Tee	Equivalent standard model option <sup>1</sup>
E5071CEP-240	9 kHz to 4.5 GHz	Type-N (f)	2	No	E5071C-240/UNQ/019
E5071CEP-280	9 kHz to 8.5 GHz	Type-N (f)	2	No	E5071C-280/UNQ/019
E5071CEP-2K5	300 kHz to 20 GHz	3.5mm (m)	2	Yes	E5071C-2K5/UNQ/019

1. Equivalent standard model options  
 Option UNQ : Standard stability time base  
 Option 019 : Standard hard disk drive

### Receiver assignment

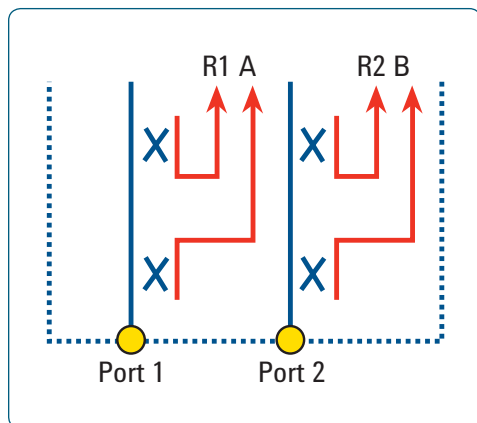

2-port test set option

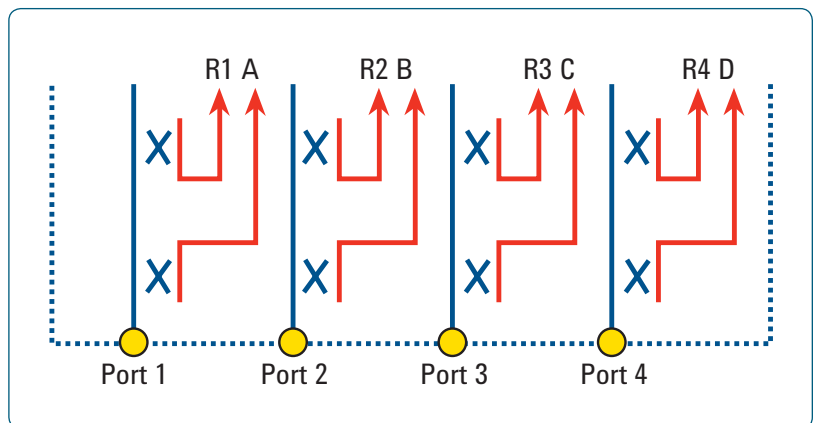

4-port test set option

# E5071C ENA Network Analyzer

## Options

To add options to a product, order the corresponding item number.

Option <sup>1</sup>	Description	Additional information
<b>Test set</b>		
Option 240	2-port test set, 9 kHz to 4.5 GHz without bias tees	Test port connector: Type-N (f)
Option 440	4-port test set, 9 kHz to 4.5 GHz without bias tees	
Option 245	2-port test set, 100 kHz to 4.5 GHz with bias tees	
Option 445	4-port test set, 100 kHz to 4.5 GHz with bias tees	
Option 260	2-port test set, 9 kHz to 6.5 GHz without bias tees	
Option 460	4-port test set, 9 kHz to 6.5 GHz without bias tees	
Option 265	2-port test set, 100 kHz to 6.5 GHz with bias tees	
Option 465	4-port test set, 100 kHz to 6.5 GHz with bias tees	
Option 280	2-port test set, 9 kHz to 8.5 GHz without bias tees	
Option 480	4-port test set, 9 kHz to 8.5 GHz without bias tees	
Option 285	2-port test set, 100 kHz to 8.5 GHz with bias tees	
Option 485	4-port test set, 100 kHz to 8.5 GHz with bias tees	
Option 2D5	2-port test set, 300 kHz to 14 GHz with bias tees	Test port connector: 3.5 mm (m) <sup>5</sup>
Option 4D5	4-port test set, 300 kHz to 14 GHz with bias tees	
Option 2K5	2-port test set, 300 kHz to 20 GHz with bias tees	
Option 4K5	4-port test set, 300 kHz to 20 GHz with bias tees	
<b>Time base</b>		
Option UNQ	Standard stability time base	Adds a higher stability time base reference.
Option 1E5	High stability time base	
<b>Hard disk drive</b>		
Option 017	Removable hard disk drive	
Option 019	Standard hard disk drive	
<b>Additional features</b>		
Option 008 <sup>2</sup>	Frequency offset mode	Adds frequency-offset sweep and harmonic measurement capabilities.
Option TDR <sup>3</sup>	Enhanced time domain analysis	Adds time domain transform, gating capabilities and graphical user interface to simplify time domain measurements.
Option 010	Time domain analysis	Adds time domain transform and gating capabilities.
Option 790 <sup>4</sup>	Measurement wizard assistant software	Adds Measurement Wizard Assistant (MWA) software to simplify your multipoint measurements with the 4-port ENA
<b>Accessories</b>		
Option 1CM	Rack mount kit	
Option 1CN	Front handle kit	
Option 1CP	Rack mount and front handle kit	
Option 810	Add keyboard	
Option 820	Add mouse	
<b>Calibration documentation</b>		
Option 1A7	ISO 17025 compliant calibration	
Option A6J	ANSI Z540 compliant calibration	

- Options are ordered using the combined model/option number, e.g. E5071C-240.
- Order the 82357B USB/GPIB interface at the same time if you want to control power meters with the E5071C. This will allow you to conduct scalar mixer calibrations (SMC), power calibrations, or receiver calibrations after power calibrations.
- Option TDR is a superset of Option 010. Option TDR and Option 010 are mutually exclusive options and there is no need to purchase both options.
- When using an ECal module with the MWA calibration wizard, a 4-port ECal module (i.e. N4431B, N4433A) is required.
- Consider purchasing Agilent 20mm TORQUE WRENCH 8710-1764

## E5092A Configurable Multiport Test Set

This guide is intended to assist you in the ordering process of the E5092A configurable multiport test set for use with the 4-port ENA (E5070B, E5071B and E5071C). Multiple multiport measurement configurations, from 50 MHz to 20 GHz, can be made by connecting included semi-rigid cables to the E5092A's front panel which accesses its internal switches.

### Step 1:<sup>1</sup> Select appropriate cable and adapter set for connection to the ENA (Optional)

- E5092A-08C** Cables and adapters for connection to E5071C Option 440/445/460/465/480/485
- E5092A-20C** Cables and adapters for connection to E5071C Option 4D5/4K5

### Step 2: Choose accessories (Optional)

- E5092A-1CM** Rack mount kit only
- E5092A-1CN** Front handle kit only
- E5092A-1CP** Rack mount kit with handle kit

### Step 3: Choose calibration certification documentation (Optional)

- E5092A-1A7** ISO 17025 compliant calibration
- E5092A-A6J** ANSI Z540 compliant calibration

### Step 4: Choose your warranty service (Optional)

- 3 year return-to-Agilent warranty and service
- 5 year return-to-Agilent warranty and service

## Documentation

The documentation for the E5092A is located in the Online Help system for the E5071C ENA network analyzer. The ENA Service Guide and Online Help system are also available on the Web site: [www.agilent.com/find/ena](http://www.agilent.com/find/ena)

## Additional product information

For additional product information, refer to the ENA brochure available on the Web site: [www.agilent.com/find/ena](http://www.agilent.com/find/ena)  
[www.agilent.com/find/multiport](http://www.agilent.com/find/multiport)

## Block diagram

### E5092A (Option 020)

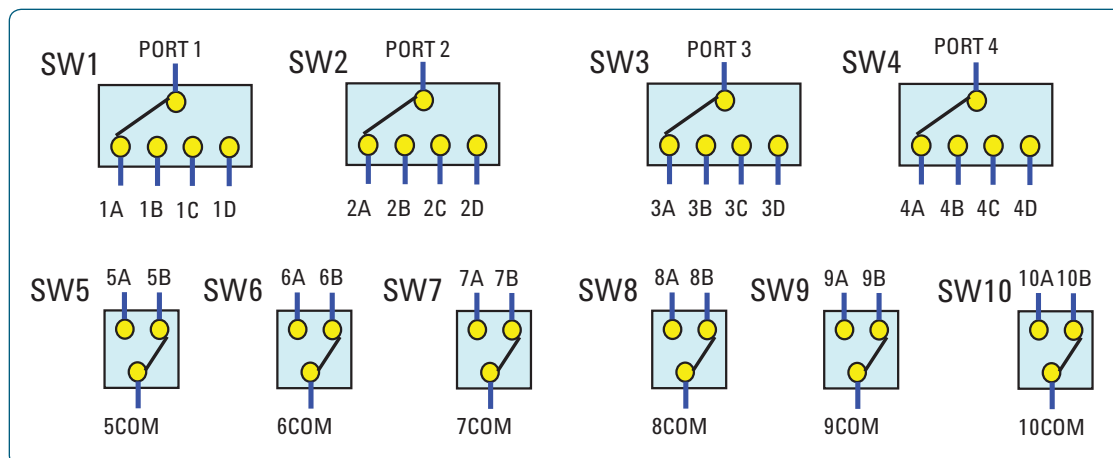

1. Semi-rigid cables are designed for connection to the E5071C and are not available for the E5070B, E5071B.

## E5092A Configurable Multiport Test Set

### Options

To add options to a product, order the corresponding option number.

Option <sup>1</sup>	Description	Additional information
<b>Test set</b> Option 020	20 GHz switching test set	Up to 22-port or 10-port full crossbar measurement.
<b>Cable adapter set</b> Option 08C	Cable and adapter set for E5071C Option 440/445/460/465/480/485 (4.5 GHz/6.5 GHz/8.5 GHz)	Adds SMA semi-rigid cables and type-N-to-SMA adapters for connection to the E5071C.
Option 20C	Cable and adapter set for the E5071C Option 4D5/4K5 (14 GHz/20 GHz)	Adds SMA semi-rigid cables and 3.5 mm-to-3.5 mm adapters for connection to the E5071C.
<b>Accessories</b> Option 1CM	Rack mount kit	Adds a rack mount kit (part number: 5063-9214) for use without handles.
Option 1CN	Front handle kit	Adds a front handle kit (part number: 5063-9227).
Option 1CP	Rack mount and front handle kit	Adds a rack mount and front handle kit (part number: 5063-9221).
<b>Calibration documentation</b> Option 1A7 Option A6J	ISO 17025 compliant calibration ANSI Z540 compliant calibration	

1. Options are ordered using the combined model/option number, e.g. E5092A-020.

## ENA Network Analyzer (E5071C)

### Additional software options

#### Option TDR Enhanced time domain analysis

Option TDR enables the ENA to view reflection and transmission responses in the time domain using a simple and intuitive graphical user interface. Use time domain to tune filters, gate out the response of fixtures and cables, characterize the impedance of transmission lines, and more.

#### Option 010 Time domain analysis

Option 010 enables the ENA to view reflection and transmission responses in the time domain. Use time domain to tune filters, gate out the response of fixtures and cables, characterize the impedance of transmission lines, and more.

#### Option 008 Frequency offset mode

Option 008 enables the ENA to set the receiver frequencies independently from where the source frequency is tuned. This ability is important for harmonic distortion measurements and for measuring frequency converting devices such as mixers and converters. Advanced calibration techniques for the ENA, such as scalar mixer calibration (SMC) or vector mixer calibration (VMC), require this option.

#### Option 790 Measurement Wizard Assistant

Option 790 provides a simple measurement procedure setup for the 4-port ENA with a multiport test set such as the E5092A. The software delivers an easy-to-use measurement wizard programs including a calibration wizard setup<sup>1</sup>, which reduces operation time for complicated, time-consuming multiport measurements.

### Time base options

#### Option UNQ Standard stability time base

Option UNQ provides following stability:  
CW accuracy:  $\pm 5$  ppm (specification)  
Source stability:  $\pm 5$  ppm (5 °C to 40 °C typical)

#### Option 1E5 High stability time base

Option 1E5 provides the following stability:  
CW accuracy:  $\pm 1$  ppm (specification)  
Source stability:  $\pm 0.05$  ppm (5 °C to 40 °C typical),  
 $\pm 0.5$  ppm/year

### Hard disk drive options

#### Option 019 Standard hard disk drive

Option 019 provides a fixed hard disk drive. The removable disk drive is not available.

#### Option 017 Removable hard disk drive

Option 017 provides a removable hard disk drive. You can remove or replace the hard disk drive for secure area operations. If a spare disk is needed, order E5071CU-018 or E5071CU-028 hard disk drive kit.



### Certification options

#### Option 1A7 ISO 17025 compliant calibration

Option 1A7 provides a complete set of measurements which test the unit to manufacturer's published specifications. Includes calibration label, ISO 17025 calibration certificate, and data report, and measurement uncertainties and guardbands on all customer specifications. Conforms to ISO 17025 and ISO 9001.

#### Option A6J ANSI Z540 compliant calibration

Option A6J provides a complete set of measurements which test the unit to manufacturer's published specifications. Includes pre- and post-adjustment data and measurement uncertainty information compliant with the ANSI/NCSL Z540 standard.

1. When using an ECal module with MWA calibration wizard, a 4-port ECal module (i.e. N4431B, N4433A) is required.

## Measurement Accessories

A complete list of RF and microwave test accessories is available on our Web site:

[www.agilent.com/find/accessories](http://www.agilent.com/find/accessories)

Accessories are available with the following connector types: 50  $\Omega$  Type-N, 3.5 mm, 7 mm, 2.4 mm, 2.92 mm, 1.85 mm, 1.0 mm and waveguide.

Test port cables and a calibration kit/ECal module should be added for a complete measurement system.

### Calibration kits

#### Coaxial measurements

Mechanical calibration kits include standards, such as opens, shorts and loads, which are measured by the network analyzer for increased measurement accuracy.

Electronic calibration (ECal) kits replace mechanical calibration standards with one solid-state calibration module that is controlled by the network analyzer via USB. ECal kits provide many different impedances to the test ports which enables a full two-port calibration to be performed quickly with a single connection. This technique reduces operator errors and connector wear and abrasion.

Choose a calibration kit for each connector type to be used.

**Economy**, includes:

- open standards (male and female)
- short standards (male and female)
- fixed-termination standards (male and female)

**Standard**, includes the devices in the economy kit and adds:

- sliding load standards<sup>1</sup> (male and female) or a series of offset shorts

**Precision**, includes the devices in the economy kit and adds:

- 50  $\Omega$  airline(s) for TRL calibration
- TRL adapters

#### Waveguide measurements

For waveguide measurements, Agilent offers mechanical calibration kits that include:

- waveguide-to-coax adapters (X, P, K, R, Q, U, and V bands)
- precision waveguide section
- flush short circuit
- fixed terminations<sup>2</sup>
- straight section

#### Cables and adapter sets

Agilent offers the following types of cables:

- single cables: semi-rigid or flexible
- cable sets: semi-rigid or flexible

There are also adapter sets that protect the test port and convert the port to the desired connector interface. These kits contain:

- one male adapter
- one female adapter

To attain the best mechanical rigidity for device connection, use a single cable and the appropriate special adapter set. To attain the greatest flexibility for device connection, use a cable set.

---

1. A sliding load is not supported by the ENA.  
2. An offset load is not supported by the ENA.



## For devices with 50 Ω Type-N connectors

### Mechanical calibration kits

- **85032F** economy: DC to 9 GHz. Includes:
  - 85032-60017 Type-N (m) fixed load
  - 85032-60018 Type-N (f) fixed load
  - 85032-60013 Type-N (m) open
  - 85032-60014 Type-N (f) open
  - 85032-60016 Type-N (m) short
  - 85032-60015 Type-N (f) short
  - **Option 85032F-100** adds:
    - 85032-60021 Type-N (f) to Type-N (f) adapter
  - **Option 85032F-200** adds:
    - 85032-60019 Type-N (m) to Type-N (m) adapter
  - **Option 85032F-300** adds:
    - 85032-60020 Type-N (m) to Type-N (f) adapter
  - **Option 85032F-500** adds:
    - 85054-60001 Type-N (f) to 7 mm adapter (two included)
    - 85054-60009 Type-N (m) to 7 mm adapter (two included)
- **85054D** economy: DC to 18 GHz. Includes:
  - 85054-60025 Type-N (m) short
  - 85054-60026 Type-N (f) short
  - 85054-60027 Type-N (m) open
  - 85054-60028 Type-N (f) open
  - 85054-60031 Type-N (f) to 7 mm adapter
  - 85054-60032 Type-N (m) to 7 mm adapter
  - 85054-60037 Type-N (f) to Type-N (f) adapter
  - 85054-60038 Type-N (m) to Type-N (m) adapter
  - 85054-60046 Type-N (m) fixed load
  - 85054-60047 Type-N (f) fixed load

### Electronic calibration kits

- **85092C RF ECal: 300 kHz to 9 GHz, 2 ports**
  - Includes:
    - Option 85092C-MOF** module with:
      - 85092-60008 Type-N (f) to Type-N (m) RF ECal module
    - Option Option 85092C-00M** module with:
      - 85092-60009 Type-N (m) to Type-N (m) RF ECal module
    - Option 85092C-00F** module with:
      - 85092-60010 Type-N (f) to Type-N (f) RF ECal module
  - Option 85092C-00A** adds:
    - 85054-60037 Type-N (f) to Type-N (f) adapter
    - 85054-60038 Type-N (m) to Type-N (m) adapter
- **N4431B Microwave ECal: 9 kHz to 13.5 GHz, 4 ports<sup>1</sup>**
  - Includes:
    - Option 020** module with:
      - N4431-60007 4 x Type-N (f) ECal module

#### N4431B-xxx mixed-connector options:

Connector type	Port A option	Port B option	Port C option	Port D Option
3.5 mm (f)	101	201	301	401
3.5 mm (m)	102	202	302	402
Type-N 50 Ω (f)	103	203	303	403
Type-N 50 Ω (m)	104	204	304	404
7-16 (f)	105	205	305	405
7-16 (m)	106	206	306	406

1. Performance from 9 kHz to 300 kHz is valid only for the E5071C ENA network analyzer with firmware version A.09.10 or higher.

□ **N4432A Microwave ECal: 300 kHz to 18 GHz, 4 ports**

Includes:

**Option 020** module with:

N4432-60003 4 x Type-N (f) ECal module

**N4432A-xxx mixed-connector options:**

Connector type	Port A option	Port B option	Port C option	Port D Option
3.5 mm (f)	101	201	301	401
3.5 mm (m)	102	202	302	402
Type-N 50 Ω (f)	103	203	303	403
Type-N 50 Ω (m)	104	204	304	404

□ **N4690B Microwave ECal: 300 kHz to 18 GHz, 2 ports**

Includes:

**Option M0F** module with:

N4690-60001 Type-N (f) to Type-N (m) ECal module

**Option 00M** module with:

N4690-60002 Type-N (m) to Type-N (m) ECal module

**Option 00F** module with:

N4690-60003 Type-N (f) to Type-N (f) ECal module

**Option 00A** adds:

85054-60037 Type-N (f) to Type-N (f) adapter

85054-60038 Type-N (m) to Type-N (m) adapter

## Cables

□ **N6314A** 50 Ω Type-N RF cable, DC to 12.4 GHz

Includes 8120-8862 one 610 mm (24 in) cable with male connectors

□ **N6315A** 50 Ω Type-N RF cable, DC to 12.4 GHz

Includes 8121-0027 one 610 mm (24 in) cable with both female and male connectors

## Adapters

□ **11853A** 50 Ω Type-N accessory kit. Includes:

1250-1472 Type-N (f) to Type-N (f) adapter (two included)

1250-1475 Type-N (m) to Type-N (m) adapter (two included)

11511A Type-N (f) short

11512A Type-N (m) short

□ **11878A** Type-N to 3.5 mm adapter kit. Includes:

1250-1744 3.5 mm (f) to 50 Ω Type-N (m) adapter

1250-1743 3.5 mm (m) to 50 Ω Type-N (m) adapter

1250-1745 3.5 mm (f) to 50 Ω Type-N (f) adapter

1250-1750 3.5 mm (m) to 50 Ω Type-N (f) adapter

□ **11524A** 7 mm to Type-N (f) adapter

□ **11525A** 7 mm to Type-N (m) adapter

□ **85130C<sup>1,2,3</sup>** 3.5 mm to Type-N Includes:

85054-60029 NMD-3.5 mm to Type-N (f)

85054-60030 NMD-3.5 mm to Type-N (m)

1. Special rugged female connector specifically for connecting to the network analyzer test port, but does not mate with a standard male connector.

2. Recommended to connect H device to E5071C option xD5/xK5 which has NMD-3.5 mm (m) connectors.

3. Consider purchasing Agilent 20mm TORQUE WRENCH 8710-1764

## For devices with 3.5 mm or SMA connectors

### Mechanical calibration kits

- **85033E** economy: DC to 9 GHz. Includes:
  - 85033-60016 3.5 mm (m) load
  - 85033-60017 3.5 mm (f) load
  - 85033-60018 3.5 mm (m) open
  - 85033-60019 3.5 mm (f) open
  - 85033-60020 3.5 mm (m) short
  - 85033-60021 3.5 mm (f) short
  - 8710-1761 torque wrench
  - Option 85033E-100** adds:
    - 85027-60005 3.5 mm (f) to 3.5 mm (f) adapter
  - Option 85033E-200** adds:
    - 85027-60007 3.5 mm (m) to 3.5 mm (m) adapter
  - Option 85033E-300** adds:
    - 85027-60006 3.5 mm (m) to 3.5 mm (f) adapter
  - Option 85033E-400** adds:
    - 1250-1744 3.5 mm (f) to 50 Ω Type-N (m) adapter
    - 1250-1743 3.5 mm (m) to 50 Ω Type-N (m) adapter
    - 1250-1745 3.5 mm (f) to 50 Ω Type-N (f) adapter
    - 1250-1750 3.5 mm (m) to 50 Ω Type-N (f) adapter
  - Option 85033E-500** adds:
    - 1250-1746 3.5 mm (m) to 7 mm adapter (two included)
    - 1250-1747 3.5 mm (f) to 7 mm adapter (two included)
  
- **85052C** precision TRL: DC to 26.5 GHz. Includes:
  - 00902-60003 3.5 mm (m) fixed load
  - 00902-60004 3.5 mm (f) fixed load
  - 85052-60006 3.5 mm (m) short
  - 85052-60007 3.5 mm (f) short
  - 85052-60008 3.5 mm (m) open
  - 85052-60009 3.5 mm (f) open
  - 85052-60032 3.5 mm (f) to 3.5 mm (f) adapter
  - 85052-60033 3.5 mm (m) to 3.5 mm (m) adapter
  - 85052-60034 3.5 mm (f) to 3.5 mm (m) adapter
  - 85052-60035 3.5 mm short TRL line
  - 85052-60036 3.5 mm long TRL line
  
- **85052D** economy: DC to 26.5 GHz. Includes:
  - 00902-60003 3.5 mm (m) fixed load
  - 00902-60004 3.5 mm (f) fixed load
  - 85052-60006 3.5 mm (m) short
  - 85052-60007 3.5 mm (f) short
  - 85052-60008 3.5 mm (m) open
  - 85052-60009 3.5 mm (f) open
  - 85052-60012 3.5 mm (f) to 3.5 mm (f) adapter
  - 85052-60013 3.5 mm (f) to 3.5 mm (m) adapter
  - 85052-60014 3.5 mm (m) to 3.5 mm (m) adapter

### Electronic calibration kits

- **85093C** RF ECal: 300 kHz to 9 GHz, 2 ports
  - Standard module includes:
    - Option M0F** with:
      - 85093-60008 3.5 mm (f) to 3.5 mm (m) ECal module
    - Option 00F** module with:
      - 85093-60010 3.5 mm (f) to 3.5 mm (f) ECal module
    - Option 00M** module with:
      - 85093-60009 3.5 mm (m) to 3.5 mm (m) ECal module
  - Option 00A** adds:
    - 85052-60012 3.5 mm (f) to 3.5 mm (f) adapter
    - 85052-60014 3.5 mm (m) to 3.5 mm (m) adapter

#### 85093C-xxx mixed-connector options:

Port A option			Port B option					
Type	(f)	(m)	Type	(f)	(m)	Type	(f)	(m)
3.5 mm	101	102	Type-N	203	204	7-16	205	206

- **N4431B Microwave ECal: 9 kHz to 13.5 GHz, 4 ports<sup>1</sup>**
  - Includes:
    - Option 010** module with:
      - N4431-60006 4 x 3.5 mm (f) ECal module

#### N4431B-xxx mixed-connector options:

Connector type	Port A option	Port B option	Port C option	Port D option
3.5 mm		201	301	401
3.5 mm (m)	102	202	302	402
Type-N 50 Ω (f)	103	203	303	403
Type-N 50 Ω (m)	104	204	304	404
7-16 (f)	105	205	305	405
7-16 (m)	106	206	306	406

- **N4433A Microwave ECal: 300 kHz to 20 GHz, 4 ports**
  - Includes:
    - Option 010** module with:
      - N4433-60003 4 x 3.5 mm (f) ECal module

1. Performance from 9 kHz to 300 kHz is valid only for the E5071C ENA network analyzer with firmware version A.09.10 or higher.

#### N4433A-xxx mixed-connector options:

Connector type	Port A option	Port B option	Port C option	Port D option
3.5 mm (f)	101	201	301	401
3.5 mm (m)	102	202	302	402

#### □ **N4691B Microwave ECal: 300 kHz to 26.5 GHz, 2 ports.**

Includes:

**Option MOF** module with:

N4691-60001 3.5 mm (f) to 3.5 mm (m) ECal module

**Option OOM** module with:

N4691-60002 3.5 mm (m) to 3.5 mm (m) ECal module

**Option OOF** module with:

N4691-60003 3.5 mm (f) to 3.5 mm (f) ECal module

**Option 00A** adds:

85052-60012 3.5 mm (f) to 3.5 mm (f) adapter

85052-60014 3.5 mm (m) to 3.5 mm (m) adapter

#### Cables

- **11500E<sup>2, 3, 4</sup>** cable, APC 3.5 mm (m), DC to 26.5 GHz  
Includes: one 610 mm (24 in) with male connectors.
- **11500F<sup>2, 3, 4</sup>** 150 cm cable, APC 3.5 mm (m), DC to 26.5 GHz  
Includes: one 1520 mm (60 in) with male connectors.
- **85131C<sup>1, 4</sup>** single, semi-rigid: 3.5 mm (f) to PSC-3.5 mm (f), 81 cm, 32 inches
- **85131D<sup>1, 4</sup>** set, semi-rigid:  
85131-60009 one 3.5 mm (f) to 3.5 mm (m), 53 cm, 21 inches,  
85131-60010 one 3.5 mm (f) to PSC-3.5 mm (f), 53 cm, 21 inches
- **85131E<sup>1, 4</sup>** single, flexible: 3.5 mm (f) to PSC-3.5 mm (f), 96.5 cm, 38 inches
- **85131F<sup>1, 4</sup>** set, flexible:  
85131-60012 one 3.5 mm (f) to 3.5 mm (m), 62.2 cm, 24.5 inches  
85131-60013 one 3.5 mm (f) to PSC-3.5 mm (f), 62.2 cm, 24.5 inches
- **85131G<sup>1, 4</sup>** single, semi-rigid: 3.5 mm (f) to 3.5 mm (m), 53 cm, 21 inches
- **85131H<sup>1, 4</sup>** single, flexible: 3.5 mm (f) to 3.5 mm (m), 62.2 cm, 24.5 inches
- **85134C<sup>1</sup>** single, semi-rigid: PSC-3.5 mm (f) to 2.4 mm (f), 81 cm, 32 inches

#### □ **85134D<sup>1</sup>** set, semi-rigid:

85134-60002 one 2.4 mm (f) to PSC-3.5 mm (f), 53 cm, 21 inches

85134-60001 one 2.4 mm (f) to PSC-3.5 mm (m), 53 cm, 21 inches

#### □ **85134E<sup>1</sup>** single, flexible: PSC-3.5 mm (f) to 2.4 mm (f), 96 cm, 38 inches

#### □ **85134F<sup>1</sup>** set, flexible:

85134-60004 one 2.4 mm (f) to PSC-3.5 mm (f), 61 cm, 24 inches

85134-60003 one 2.4 mm (f) to PSC-3.5 mm (m), 61 cm, 24 inches

#### □ **85134G<sup>1</sup>** single, semi-rigid: 2.4 mm (f) to PSC-3.5 mm (m), 53 cm, 21 inches

#### □ **85134H<sup>1</sup>** single, flexible: 2.4 mm (f) to PSC-3.5 mm (m), 61 cm, 24 inches

#### □ **N4419AK20** single, flexible: 3.5 mm (m) to 3.5 mm (f), 91.4 cm, 36 inches

#### □ **Z5623A-B20** set of 4, flexible: 3.5 mm (m) to 3.5 mm (m), 91.4 cm, 36 inches (phase-matched)

#### Adapters

#### □ **11853A** 50 Ω Type-N accessory kit.

Includes:

1250-1472 Type-N (f) to Type-N (f) adapter (two included)

1250-1475 Type-N (m) to Type-N (m) adapter (two included)

85032-60009 Type-N (f) short

85032-60008 Type-N (m) short

#### □ **11878A** Type-N to 3.5 mm adapter kit.

Includes:

1250-1744 3.5 mm (f) to 50 Ω Type-N (m) adapter

1250-1743 3.5 mm (m) to 50 Ω Type-N (m) adapter

1250-1745 3.5 mm (f) to 50 Ω Type-N (f) adapter

1250-1750 3.5 mm (m) to 50 Ω Type-N (f) adapter

#### □ **11524A** 7 mm to Type-N (f) adapter

#### □ **11525A** 7 mm to Type-N (m) adapter

#### □ **85130C<sup>1</sup>** 3.5 mm to Type-N

Includes:

85054-60029 NMD-3.5 mm to Type-N (f)

85054-60030 NMD-3.5 mm to Type-N (m)

#### □ **85130D<sup>1</sup>** 3.5 mm to 3.5 mm

Includes:

85130-60005 NMD-3.5 mm to PSC-3.5 mm (f)

85130-60006 NMD-3.5 mm to PSC-3.5 mm (m)

#### □ **85130F<sup>1</sup>** 2.4 mm to 3.5 mm

1. Special rugged female connector specifically for connecting to the network analyzer test port, but does not mate with a standard male connector.

2. 1250-1744 3.5 mm (f) to 50 Ω Type-N (m) adapters are recommended to connect to the E5071C Option x4x, x6x, and x8x test ports, which have Type-N (f) connectors.

3. NMD-3.5 mm (f) to 3.5 mm (f), or 3.5 mm (f) to 3.5 mm (f) adapters are recommended to connect to the E5071C Option xD5, xK5, which have NMD-3.5 mm (m) connectors.

4. Consider purchasing Agilent 20mm TORQUE WRENCH 8710-1764

## For devices with 75 $\Omega$ Type-N connectors

### Mechanical calibration kits

- **85036B** DC to 3 GHz, includes:
  - 00909-60019 75  $\Omega$  Type-N (m) broadband load
  - 00909-60020 75  $\Omega$  Type-N (f) broadband load
  - 85036-60012 75  $\Omega$  Type-N (m) short
  - 85036-60011 75  $\Omega$  Type-N (f) short
  - 85032-60007 75  $\Omega$  Type-N (m) open
  - 85032-20001 75  $\Omega$  Type-N (f) open body
  - 85036-60010 75  $\Omega$  Type-N (f) open center conductor extender
  - 85036-60013 75  $\Omega$  Type-N (m) to (m) adapter
  - 85036-60014 75  $\Omega$  Type-N (f) to (f) adapter
  - 85036-60015 75  $\Omega$  Type-N (m) to (f) adapter
- **85036E** DC to 3 GHz, includes:
  - 00909-60019 75  $\Omega$  Type-N (m) broadband load
  - 85036-60016 75  $\Omega$  Type N (m) combined open/short

### Adapters

- **11852B** Minimum-loss pad  
**Option 11852B-004** Type-N connectors, 50  $\Omega$  (m) to 75  $\Omega$  (f)

Calibration must be done with a 75  $\Omega$  calibration kit using an 11852B minimum-loss pad, and impedance conversion to 75  $\Omega$  using the ENA's fixture simulator function is required.

## For devices with waveguide

### Mechanical calibration kits

#### X Band

- **X11644A** standard, WR-90: 8.2 to 12.4 GHz.  
Includes:
  - 00896-60008 X-band standard section
  - 00910-60003 X-band termination
  - 11644-20018 X-band short
  - 11644-20021 X-band shim
- **85132F** cable set (set of 2, flexible 7 mm to 3.5 mm, 62.9 cm each, 24.75 inches each)
- **85135F** cable set (set of 2, flexible, 7 mm to 2.4 mm, 53 cm each, 21 inches each)
- **X281C** adapter (included in calibration kit):  
WR-90 to 7 mm

#### P Band

- **P11644A** standard, WR-62: 12.4 to 18 GHz.  
Includes:
  - 00896-60007 P-band standard section
  - 00910-60002 P-band termination
  - 11644-20017 P-band short
  - 11644-20020 P-band shim
- **85132F** cable set (set of 2, flexible, 7 mm to 3.5 mm, 62.9 cm each, 24.75 inches each)
- **85135F** cable set (set of 2, flexible, 7 mm to 2.4 mm, 53 cm each, 21 inches each)
- **P281C** adapter (included in calibration kit):  
WR-62 to 7 mm

#### K Band

- **K11644A** standard, WR-42: 18 to 26.5 GHz.  
Includes:
  - 00896-60006 K-band standard section
  - 00910-60001 K-band termination
  - 11644-20016 K-band short
  - 11644-20019 K-band shim
- **85134F** cable set (set of 2, flexible, 3.5 mm to 2.4 mm, 53 cm each, 21 inches each)
- **K281C** adapter (included in calibration kit):  
WR-42 to 3.5 mm (f)  
**Option 012<sup>1</sup>** WR-42 to 3.5 mm (m)

---

1. For this option order K281C-012.

## Additional Accessories

### Power limiters

- **N9355B** power limiter, 10 dBm limiting threshold, 10 MHz to 18 GHz, Type-N
- **N9356B** power limiter, 25 dBm limiting threshold, 10 MHz to 18 GHz, Type-N
- **N9355C** power limiter, 10 dBm limiting threshold, 10 MHz to 26.5 GHz, 3.5 mm
- **N9356C** power limiter, 25 dBm limiting threshold, 10 MHz to 26.5 GHz, 3.5 mm

### DC blocks

- **N9398C** DC block, 16 V maximum working voltage, 50 kHz to 26.5 GHz, 3.5 mm
- **N9399C** DC block, 50 V maximum working voltage, 700 kHz to 26.5 GHz, 3.5 mm
- **11742A**, 50 V maximum working voltage, 45 MHz to 26.5 GHz, 3.5 mm

### Amplifiers

- **87405B** pre-amplifier, 22 dB gain, 10 MHz to 4 GHz
- **87405C** pre-amplifier, 25 dB gain, 100 MHz to 18 GHz
- **87415A** amplifier, 25 dB gain, 2 to 8 GHz
- **83006A** amplifier, 20 dB gain, 10 MHz to 26.5 GHz

### Attenuators

- **8491A** fixed attenuator, DC to 12.4 GHz, Type-N
- **8493A** fixed attenuator, DC to 12.4 GHz, SMA

### RF & microwave switches

- **N1810TL** SPDT switch, terminated, DC to 26.5 GHz
- **N1810UL** SPDT switch, unterminated, DC to 26.5 GHz
- **87104B** SP4T switch, terminated, DC to 20 GHz
- **87106B** SP6T switch, terminated, DC to 20 GHz
- **87222C** transfer switch, DC to 26.5 GHz
- **L7104B** SP4T switch, terminated, DC to 20 GHz
- **L7106B** SP6T Switch, terminated, DC to 20 GHz
- **L7222C** transfer switch, DC to 26.5 GHz
- **P9400C** solid state PIN diode transfer switch, 100 MHz to 18 GHz
- **P9402C** SPDT solid state PIN diode switch, 100 MHz to 18 GHz
- **P9404C** SP4T solid state PIN diode switch, 100 MHz to 18 GHz
- **U9397C** SPDT solid state FET hybrid switch, 300 kHz to 18 GHz
- **U9400C** solid state FET hybrid transfer switch, 300 KHz to 18 GHz

### Power meters and sensors<sup>1</sup>

Recommended for source output power calibration.

- **E4416A<sup>1</sup>** single-channel EPM-P series power meter
- **E4417A<sup>1</sup>** dual-channel EPM-P series power meter
- **E4418B<sup>1</sup>** single-channel EPM series power meter
- **E4419B<sup>1</sup>** dual-channel EPM series power meter
- **N1911A<sup>1</sup>** single-channel P-series power meter
- **N1912A<sup>1</sup>** dual-channel P-series power meter
- **8482A** power sensor, 100 kHz to 4.2 GHz, Type-N (m), 100 mW
- **E9304A-H18** power sensor, 9 kHz to 18 GHz, Type-N (m), 100 mW
- **E4412A** CW power sensor, 10 MHz to 18 GHz, Type-N (m), 200 mW
- **E4413A** CW power sensor, 50 MHz to 26.5 GHz, 3.5 mm (m), 200 mW
- **N1921A** power sensor 50 MHz to 18 GHz, Type-N (m)
- **N1922A** power sensor 50 MHz to 40 GHz, 2.4 mm (m)
- **U2000A/B/H<sup>2</sup>** USB power sensor, 10 MHz to 18 GHz, Type-N (m)
- **U2001A/B/H<sup>2</sup>** USB power sensor, 10 MHz to 6 GHz, Type-N (m)
- **U2002A/H<sup>2</sup>** USB power sensor, 50 MHz to 24 GHz, 3.5 mm (m)
- **U2004A<sup>2</sup>** USB power sensor, 9 kHz to 6 GHz, Type-N (m)

### Probes

- **N1021B** 18 GHz differential TDR/TDT passive probe kit
- **N1020A** 6 GHz single-ended TDR/TDT passive probe
- **85024A** high-frequency probe, 300 kHz to 3 GHz

## General accessories

### System racks

- **1CN005A** handle kit, may be ordered as option 1CN (two included)
- **1CM015A** rack mount kit, for use without handles: may be ordered as option 1CM
- **1CP009A** rack mount kit, for use with previously supplied handles; may be ordered as option 1CP
- **E3663AC** rack mount rail kit, for use with 5063-9216 or 5188-4430
- **1181BZ** test mobile system cart

### Interface cables

The following GPIB cables can be used to connect the network analyzer with an external device such as a computer

- **10833A** GPIB cable, 1.0 m (3.3 ft)
- **10833B** GPIB cable, 2.0 m (6.6 ft)
- **10833C** GPIB cable, 4.0 m (13.1 ft)
- **10833D** GPIB cable, 0.5 m (1.6 ft)
- **82357B** GPIB to USB interface, necessary to control a power meter or signal generator with the E5071C.

### Monitors

- XGA-compatible monitor

### Printers

- USB printers with Microsoft® Windows printer driver

### Other

- 8710-1764 WRENCH - TORQUE 8 IN/LB, 20 MM OPEN END

1. Order the 82357B USB/GPIB interface to control a power meter by the E5071C.

2. To use the U200x USB power sensors for source power calibration, the E5071C ENA firmware version A.09.2x or higher is required.



## Upgrade kits

### Upgrade kits for the E5071C

#### Protecting your hardware investment

The E5071C ENA network analyzer is a safe investment because of its flexibility. Easily upgrade any ENA software or hardware feature whenever you need that feature.

#### Ordering instructions

To upgrade an existing E5071C, order the corresponding model number as the followings. For further information, such as time required by the service center, visit:

[http://www.agilent.com/find/ena\\_upgrades](http://www.agilent.com/find/ena_upgrades)

#### Software option upgrades

- a) Add Frequency-offset mode option (Customer installable):  
Order the E5003A with E5003A-1FP  
Frequency-offset mode for the E5071C.
- b) Add Enhanced time domain analysis option (Return to Service Center for Installation)
  - b-1) Order E5008A with E5008A-1FP Enhanced time domain analysis for the E5071C, if Option 010 is not already installed.
  - b-2) Order E5009A with E5009A-1FP Enhanced time domain analysis from Option 010 for the E5071C, if Option 010 is already installed.
- c) Add Time domain analysis option (Customer installable):  
Order the E5004A with E5004A-1FP Time domain analysis for the E5071C.
- d) Add Measurement Wizard Assistant software (Customer installable):  
Order the E5005A with E5005A-1FP Measurement wizard assistant software for the E5071C.

#### Hardware option upgrades

##### (Installed by the Agilent service center)

Please refer to "E5071C Test set option table" below and the "E5071C Hardware upgrade option matrix" on page 14 of this document for help selecting the proper upgrade options.

### E5071C Upgrade option list

#### a) Maximum frequency upgrade

<b>E5071CU-260</b>	from 4.5 GHz to 6.5 GHz for E5071C-240
<b>E5071CU-265</b>	from 4.5 GHz to 6.5 GHz for E5071C-245
<b>E5071CU-280</b>	from 4.5 GHz to 8.5 GHz for E5071C-240
<b>E5071CU-281</b>	from 6.5 GHz to 8.5 GHz for E5071C-260
<b>E5071CU-285</b>	from 4.5 GHz to 8.5 GHz for E5071C-245

<b>E5071CU-286<sup>3</sup></b>	from 6.5 GHz to 8.5 GHz for E5071C-265
<b>E5071CU-2D5<sup>3</sup></b>	from 8.5 GHz to 14 GHz for E5071C-280/285
<b>E5071CU-2K5<sup>3</sup></b>	from 8.5 GHz to 20 GHz for E5071C-280/285
<b>E5071CU-2K6</b>	from 14 GHz to 20 GHz for E5071C-2D5
<b>E5071CU-460</b>	from 4.5 GHz to 6.5 GHz for E5071C-440
<b>E5071CU-465</b>	from 4.5 GHz to 6.5 GHz for E5071C-445
<b>E5071CU-480</b>	from 4.5 GHz to 8.5 GHz for E5071C-440
<b>E5071CU-481</b>	from 6.5 GHz to 8.5 GHz for E5071C-460
<b>E5071CU-485</b>	from 4.5 GHz to 8.5 GHz for E5071C-445
<b>E5071CU-486</b>	from 6.5 GHz to 8.5 GHz for E5071C-465
<b>E5071CU-4D5<sup>3</sup></b>	from 8.5 GHz to 14 GHz for E5071C-480/485
<b>E5071CU-4K5<sup>3</sup></b>	from 8.5 GHz to 20 GHz for E5071C-480/485
<b>E5071CU-4K6<sup>3</sup></b>	from 14 GHz to 20 GHz for E5071C-4D5

#### b) Add bias tees<sup>1</sup>

<b>E5071CU-100</b>	Add bias tees for E5071C-240
<b>E5071CU-101</b>	Add bias tees for E5071C-280
<b>E5071CU-102</b>	Add bias tees for E5071C-440
<b>E5071CU-103</b>	Add bias tees for E5071C-480
<b>E5071CU-104</b>	Add bias tees for E5071C-260
<b>E5071CU-105</b>	Add bias tees for E5071C-460

#### c) Lower frequency limit upgrade<sup>2</sup>

<b>E5071CU-200</b>	Lower limit upgrade from 100 kHz to 9 kHz for E5071C-245
<b>E5071CU-201</b>	Lower limit upgrade from 100 kHz to 9 kHz for E5071C-285
<b>E5071CU-202</b>	Lower limit upgrade from 100 kHz to 9 kHz for E5071C-445
<b>E5071CU-203</b>	Lower limit upgrade from 100 kHz to 9 kHz for E5071C-485
<b>E5071CU-204</b>	Lower limit upgrade from 100 kHz to 9 kHz for E5071C-265
<b>E5071CU-205</b>	Lower limit upgrade from 100 kHz to 9 kHz for E5071C-465

#### d) Measurement port upgrade

<b>E5071CU-300</b>	Port up from 2 ports to 4 ports for E5071C-240
<b>E5071CU-301</b>	Port up from 2 ports to 4 ports for E5071C-245
<b>E5071CU-302</b>	Port up from 2 ports to 4 ports for E5071C-280
<b>E5071CU-303</b>	Port up from 2 ports to 4 ports for E5071C-285
<b>E5071CU-304</b>	Port up from 2 ports to 4 ports for E5071C-2K5
<b>E5071CU-305</b>	Port up from 2 ports to 4 ports for E5071C-260
<b>E5071CU-306</b>	Port up from 2 ports to 4 ports for E5071C-265
<b>E5071CU-307</b>	Port up from 2 ports to 4 ports for E5071C-2D5

1. Minimum frequency changes from 9 kHz to 100 kHz.

2. Bias tees are removed.

3. Consider purchasing Agilent 20mm TORQUE WRENCH 8710-1764 at the same time for microwave test port connector of E5071CU-2D5, E5071CU-2K5, E5071CU-2K6, E5071CU-4D5, E5071CU-4K5 and E5071CU-4K6

### e) Add high stability time base option

**E5071CU-1E5** Add high stability time base

### f) Add removable hard disk drive feature

**E5071CU-017** Upgrade to removable hard disk drive. E5071CU-017 is only applicable for the instrument with S/N MY461xxxxx and it will be discontinued on 1 Oct. 2011. New hard disk is not included in this option and an original disk is reused. Order E5071CU-018 if spare disk is necessary.

**E5071CU-018<sup>3</sup>** Hard disk drive kit, applicable for E5071C S/N MY461xxxxx and will be discontinued on 1 Oct. 2011.

**E5071CU-028<sup>3</sup>** Hard disk drive kit for E5071C S/N MY462xxxxx (spare hard disk, customer installable)

### g) CPU upgrade

**E5071CU-040** Upgrade digital HW module, from 1.3GHz CPU to 1.86GHz

## E5071C Test set option table

Frequency range & bias tees	Number of test ports	
	2-port	4-port
9 kHz to 4.5 GHz without bias tees	240	440
100 kHz to 4.5 GHz with bias tees	245	445
9 kHz to 6.5 GHz without bias tees	260	460
100 kHz to 6.5 GHz with bias tees	265	465
9 kHz to 8.5 GHz without bias tees	280	480
100 kHz to 8.5 GHz with bias tees	285	485
300 kHz to 14 GHz with bias tees	2D5	4D5
300 kHz to 20 GHz with bias tees	2K5	4K5

- When upgrading the maximum frequency, number of ports, bias-tees or lower frequency limit, please be aware that the upgrade options listed in the "E5071C Hardware upgrade option matrix" need to be ordered as well (e.g. To upgrade the unit from Opt. 240 to Opt. 480, order "E5071CU-300" and "E5071CU-480" respectively).
- "Add high stability time base" and "Upgrade to removable HDD" can be ordered at the same time as the upgrade options for frequency, number of ports, bias-tees or lower frequency limit.

3. When using E5071CU-018, E5071C-017 or E5071CU-028 removable hard disk drive is required.



## E5071C Hardware upgrade options matrix

From	To	Upgrade options to order	From	To	Upgrade options to order	
<b>240</b>	245	E5071CU-100	<b>280</b>	285	E5071CU-101	
	260	E5071CU-260		480	E5071CU-302	
	265	E5071CU-100 + E5071CU-265		485	E5071CU-101 + E5071CU-303	
	280	E5071CU-280		2D5	E5071CU-2D5	
	285	E5071CU-100 + E5071CU-285		4D5	E5071CU-2D5 + E5071CU-307	
	440	E5071CU-300		2K5	E5071CU-2K5	
	445	E5071CU-100 + E5071CU-301		4K5	E5071CU-2K5 + E5071CU-304	
	460	E5071CU-260 + E5071CU-305		<b>285</b>	280	E5071CU-201
	465	E5071CU-100 + E5071CU-265+ E5071CU-306			480	E5071CU-201 + E5071CU-302
	480	E5071CU-280 + E5071CU-302			485	E5071CU-303
	485	E5071CU-100 + E5071CU-285+ E5071CU-303			2D5	E5071CU-2D5
	2D5	E5071CU-280 + E5071CU-2D5			4D5	E5071CU-2D5 + E5071CU-307
	4D5	E5071CU-280 + E5071CU-2D5 + E5071CU-307			2K5	E5071CU-2K5
2K5	E5071CU-280 + E5071CU-2K5	4K5	E5071CU-2K5 + E5071CU-304			
4K5	E5071CU-280 + E5071CU-2K5 + E5071CU-304	<b>2D5</b>	2K5	E5071CU-2K6		
<b>245</b>	240		E5071CU-200	4D5	E5071CU-307	
	260		E5071CU-200 + E5071CU-260	4K5	E5071CU-2K6 + E5071CU-304	
	265	E5071CU-265	<b>2K5</b>	4K5	E5071CU-304	
	280	E5071CU-200 + E5071CU-280		<b>440</b>	445	E5071CU-102
	285	E5071CU-285	460		E5071CU-460	
	440	E5071CU-200 + E5071CU-300	465		E5071CU-102 + E5071CU-465	
	445	E5071CU-301	480		E5071CU-480	
	460	E5071CU-200 + E5071CU-260 + E5071CU-305	485		E5071CU-102 + E5071CU-485	
	465	E5071CU-265 + E5071CU-306	4D5		E5071CU-480 + E5071CU-4D5	
	480	E5071CU-200 + E5071CU-280 + E5071CU-302	4K5	E5071CU-480 + E5071CU-4K5		
	485	E5071CU-285 + E5071CU-303	<b>445</b>	440	E5071CU-202	
	2D5	E5071CU-285 + E5071CU-2D5		460	E5071CU-202 + E5071CU-460	
	4D5	E5071CU-285 + E5071CU-2D5 + E5071CU-307		465	E5071CU-465	
2K5	E5071CU-285 + E5071CU-2K5	480		E5071CU-202 + E5071CU-480		
4K5	E5071CU-285 + E5071CU-2K5 + E5071CU-304	485		E5071CU-485		
<b>260</b>	265	E5071CU-104	4D5	E5071CU-485 + E5071CU-4D5		
	280	E5071CU-281	4K5	E5071CU-485 + E5071CU-4K5		
	285	E5071CU-104 + E5071CU-286	<b>460</b>	465	E5071CU-105	
	460	E5071CU-305		480	E5071CU-481	
	465	E5071CU-104 + E5071CU-306		485	E5071CU-105 + E5071CU-486	
	480	E5071CU-281 + E5071CU-302		4D5	E5071CU-481 + E5071CU-4D5	
	485	E5071CU-104 + E5071CU-286 + E5071CU-303	4K5	E5071CU-481 + E5071CU-4K5		
	2D5	E5071CU-281 + E5071CU-2D5	<b>465</b>	460	E5071CU-205	
	4D5	E5071CU-281 + E5071CU-2D5 + E5071CU-307		480	E5071CU-205 + E5071CU-481	
	2K5	E5071CU-281 + E5071CU-2K5		485	E5071CU-486	
	4K5	E5071CU-281 + E5071CU-2K5 + E5071CU-304		4D5	E5071CU-486 + E5071CU-4D5	
<b>265</b>	260	E5071CU-204	4K5	E5071CU-486 + E5071CU-4K5		
	280	E5071CU-204 + E5071CU-281	<b>480</b>	485	E5071CU-103	
	285	E5071CU-286		4D5	E5071CU-4D5	
	460	E5071CU-204 + E5071CU-305		4K5	E5071CU-4K5	
	465	E5071CU-306	<b>485</b>	480	E5071CU-203	
	480	E5071CU-204 + E5071CU-281 + E5071CU-302		4D5	E5071CU-4D5	
	485	E5071CU-286 + E5071CU-303		4K5	E5071CU-4K5	
	2D5	E5071CU-286 + E5071CU-2D5		<b>4D5</b>	4K5	E5071CU-4K6
	4D5	E5071CU-286 + E5071CU-2D5 + E5071CU-307	<b>UNQ</b>		1E5	E5071CU-1E5
	2K5	E5071CU-286 + E5071CU-2K5			<b>019</b>	017
	4K5	E5071CU-286 + E5071CU-2K5 + E5071CU-304				

## Application and product notes

*Introduction to the Fixture Simulator Function of the ENA Series RF Network Analyzers: Network De-embedding/Embedding and Balanced Measurement*, Product Note E5070/71-1 Literature number 5988-4923EN

*Evolution of Test Automation Using Built-in VBA with the ENA Series RF Network Analyzers*, Product Note E5070/71-2 Literature number 5988-6192EN

*On-wafer Multiport Calibration Using the ENA Series RF Network Analyzer with the Cascade Microtech Probing System*, Product Note E5070/71-3 Literature number 5988-5886EN

*In-Fixture Characterization Using the ENA Series RF Network Analyzer with Cascade Microtech Probing System*, Product Note E5070/71-4 Literature number 5988-6522EN

*Improve the Circuit Evaluation Efficiency of Wireless LAN Chip Set Design*, Application Note 1463-2 Literature number 5988-9803EN

*Impedance Characteristic Evaluation of SMD by Using the ENA with Inter-Continental Microwave (ICM)* Application Note 1463-5 Literature number 5989-0547EN

*Accurate Mixer Measurements Using the Frequency-Offset Mode*, Application Note 1463-6 Literature number 5989-1420EN

*7 Reasons to Migrate from Your 8753 to an ENA Network Analyzer* Application Note 1478 Literature number 5989-0206EN

*Multiport Solutions for E5071C ENA RF Network Analyzers Using External Switches* Literature number 5989-7916EN

*Advanced Measurement Techniques for RF Amplifiers Using Unique Functions of the Agilent E5071C ENA* Literature number 5989-6522EN

*Measurement Wizard Assistant software for ENA/E5091A* Literature number 5989-4855EN

*Comprehensive Multiport Solution for the ENA Network Analyzer* Literature number 5989-8737EN

*E5071C ENA Option TDR Enhanced Time Domain Analysis Option* Literature number 5990-5237EN

*Correlation between TDR oscilloscope and VNA generated time domain waveform* Literature number 5990-5238EN

## Literature and information

*ENA Network Analyzers Brochure* Literature number 5989-5478EN

*ENA Network Analyzers Data Sheet* Literature number 5989-5479EN

*Agilent Network Analyzer Selection Guide* Literature number 5989-7603EN

*ENA-L RF Network Analyzers Brochure* Literature number 5989-0167EN

*ENA-L RF Network Analyzers Data Sheet* Literature number 5989-0018EN

*Test Solutions for Multiport and Balanced Devices Selection Guide* Literature number 5988-2461EN

*Agilent RF & MW Test Accessories Catalog* Literature number 5968-4314EN

## Key web resources for additional information on the ENA Series, visit:

[www.agilent.com/find/ena](http://www.agilent.com/find/ena)



### Agilent Email Updates

[www.agilent.com/find/emailupdates](http://www.agilent.com/find/emailupdates)

Get the latest information on the products and applications you select.



[www.lxistandard.org](http://www.lxistandard.org)

LAN eXtensions for Instruments puts the power of Ethernet and the Web inside your test systems. Agilent is a founding member of the LXI consortium.

### Agilent Channel Partners

[www.agilent.com/find/channelpartners](http://www.agilent.com/find/channelpartners)

Get the best of both worlds: Agilent's measurement expertise and product breadth, combined with channel partner convenience.



Agilent Advantage Services is committed to your success throughout your equipment's lifetime. To keep you competitive, we continually invest in tools and processes that speed up calibration and repair and reduce your cost of ownership. You can also use Infoline Web Services to manage equipment and services more effectively. By sharing our measurement and service expertise, we help you create the products that change our world.



[www.agilent.com/quality](http://www.agilent.com/quality)

## [www.agilent.com](http://www.agilent.com)

For more information on Agilent Technologies' products, applications or services, please contact your local Agilent office. The complete list is available at:

[www.agilent.com/find/contactus](http://www.agilent.com/find/contactus)

### Americas

Canada	(877) 894 4414
Brazil	(11) 4197 3500
Mexico	01800 5064 800
United States	(800) 829 4444

### Asia Pacific

Australia	1 800 629 485
China	800 810 0189
Hong Kong	800 938 693
India	1 800 112 929
Japan	0120 (421) 345
Korea	080 769 0800
Malaysia	1 800 888 848
Singapore	1 800 375 8100
Taiwan	0800 047 866
Other AP Countries	(65) 375 8100

### Europe & Middle East

Belgium	32 (0) 2 404 93 40
Denmark	45 70 13 15 15
Finland	358 (0) 10 855 2100
France	0825 010 700*
	*0.125 €/minute
Germany	49 (0) 7031 464 6333
Ireland	1890 924 204
Israel	972-3-9288-504/544
Italy	39 02 92 60 8484
Netherlands	31 (0) 20 547 2111
Spain	34 (91) 631 3300
Sweden	0200-88 22 55
United Kingdom	44 (0) 131 452 0200

For other unlisted Countries:

[www.agilent.com/find/contactus](http://www.agilent.com/find/contactus)

Revised: June 8, 2011

Product specifications and descriptions in this document subject to change without notice.

© Agilent Technologies, Inc. 2012  
Published in USA, February 22, 2012  
5989-5480EN

Microsoft is a U.S. registered trademark of Microsoft Corporation.



# Agilent Technologies