

Agilent 34970A/34972A Data Acquisition / Switch Unit

Service Guide



Agilent Technologies

Notices

© Agilent Technologies, Inc. 2009-2010

No part of this manual may be reproduced in any form or by any means (including electronic storage and retrieval or translation into a foreign language) without prior agreement and written consent from Agilent Technologies, Inc. as governed by United States and international copyright laws.

Manual Part Number

34972-90010

First Edition, December 2009
Second Edition, September 2010

Printed in Malaysia

Agilent Technologies, Inc.
900 S. Taft Ave.
Loveland, CO 80537 USA

Adobe, the Adobe Logo, Acrobat and the Acrobat Logo are trademarks of Adobe Systems Incorporated.

Microsoft is either a registered trademark or a trademark of Microsoft Corporation in the United States and/or other countries.

Windows and MS Windows are U.S. registered trademarks of Microsoft Corporation.

Software Updates/Licenses

Periodically, Agilent releases software updates to fix known defects and incorporate product enhancements. To search for software updates and the latest documentation for your product, go to the product page at:

www.agilent.com/find/34970A
www.agilent.com/find/34972A

A portion of the software in this product is licensed under terms of the General Public License Version 2 ("GPLv2"). The text of the license and source code can be found at:

www.agilent.com/find/GPLV2

This product utilizes Microsoft Windows CE. Agilent highly recommends that all Windows-based computers connected to Windows CE instruments utilize current anti-virus software. For more information, go to the product page at:

www.agilent.com/find/34970A
www.agilent.com/find/34972A

Declaration of Conformity

Declarations of Conformity for this product and for other Agilent products may be downloaded from the Web. Go to <http://regulations.corporate.agilent.com> and click on "Declarations of Conformity." You can then search by product number to find the latest Declaration of Conformity.

Warranty

The material contained in this document is provided "as is," and is subject to being changed, without notice, in future editions. Further, to the maximum extent permitted by applicable law, Agilent disclaims all warranties, either express or implied, with regard to this manual and any information contained herein, including but not limited to the implied warranties of merchantability and fitness for a particular purpose. Agilent shall not be liable for errors or for incidental or consequential damages in connection with the furnishing, use, or performance of this document or of any information contained herein. Should Agilent and the user have a separate written agreement with warranty terms covering the material in this document that conflict with these terms, the warranty terms in the separate agreement shall control.

Technology Licenses

The hardware and/or software described in this document are furnished under a license and may be used or copied only in accordance with the terms of such license.

Restricted Rights Legend

If software is for use in the performance of a U.S. Government prime contract or subcontract, Software is delivered and licensed as "Commercial computer software" as defined in DFAR 252.227-7014 (June 1995), or as a "commercial item" as defined in FAR 2.101(a) or as "Restricted computer software" as defined in FAR 52.227-19 (June 1987) or any equivalent agency regulation or contract clause. Use, duplication or disclosure of Software is subject to Agilent Technologies' standard commercial license terms, and non-DOD Departments and Agencies of the U.S. Government will receive no greater than Restricted Rights as defined in FAR 52.227-19(c)(1-2) (June 1987). U.S. Government users will receive no greater than Limited Rights as defined in FAR 52.227-14 (June 1987) or DFAR 252.227-7015 (b)(2) (November 1995), as applicable in any technical data.

Safety Notices

CAUTION

A **CAUTION** notice denotes a hazard. It calls attention to an operating procedure, practice, or the like that, if not correctly performed or adhered to, could result in damage to the product or loss of important data. Do not proceed beyond a **CAUTION** notice until the indicated conditions are fully understood and met.

WARNING

A **WARNING** notice denotes a hazard. It calls attention to an operating procedure, practice, or the like that, if not correctly performed or adhered to, could result in personal injury or death. Do not proceed beyond a **WARNING** notice until the indicated conditions are fully understood and met.

Additional Safety Notices

The following general safety precautions must be observed during all phases of operation of this instrument. Failure to comply with these precautions or with specific warnings or instructions elsewhere in this manual violates safety standards of design, manufacture, and intended use of the instrument. Agilent Technologies assumes no liability of the customer's failure to comply with the requirements.

General

Do not use this product in any manner not specified by the manufacturer. The protective features of this product may be impaired if it is used in a manner not specified in the operation instructions.

Before Applying Power

Verify that all safety precautions are taken. Make all connections to the unit before applying power and select the appropriate power line voltage on the fuse module.

Ground the Instrument

This product is provided with protective earth terminals. To minimize shock hazard, the instrument must be connected to the ac power mains through a grounded power cable, with the ground wire firmly connected to an electrical ground (safety ground) at the power outlet. Any interruption of the protective (grounding) conductor or disconnection of the protective earth terminal will cause a potential shock hazard that could result in personal injury.

Do Not Operate in an Explosive Atmosphere

Do not operate the instrument in the presence of flammable gases or fumes.

Do Not Remove the Instrument Cover

Only qualified, service-trained personnel who are aware of the hazards involved should remove instrument covers. Always disconnect the power cable and

any external circuits before removing the instrument cover.

Do Not Modify the Instrument

Do not install substitute parts or perform any unauthorized modification to the product. Return the product to an Agilent Sales and Service Office for service and repair to ensure that safety features are maintained.

In Case of Damage

Instruments that appear damaged or defective should be made inoperative and secured against unintended operation until they can be repaired by qualified service personnel.

Safety Symbols

CAUTION

Unless otherwise noted in the specifications, this instrument or system is intended for indoor use in an installation category II, pollution degree 2 environment per IEC 61010-1 and 664 respectively. It is designed to operate at a maximum relative humidity of 20% to 80% at 40 °C or less (non-condensing). This instrument or system is designed to operate at altitudes up to 2000 meters, and at temperatures between 0 °C and 55 °C.

Technical Support

If you have questions about your shipment, or if you need information about warranty, service, or technical support, contact Agilent Technologies:

In the United States: (800) 829-4444

In Europe: 31 20 547 2111

In Japan: 0120-421-345

Or go to

www.agilent.com/find/assist

for information on contacting Agilent in your country of specific location. You can also contact your Agilent Technologies Representative.



Alternating current



Frame or chassis terminal



Standby supply. Unit is not completely disconnected from AC mains when switch is off.



Caution, risk of electric shock



Caution, refer to accompanying documents



Earth ground terminal

CAT I

IEC Measurement



The CE mark is a registered trademark of the European



The CSA mark is a registered trademark of the CSA-International.



N10149

The C-tick mark is a registered trademark of the Spectrum Management Agency of Australia. This signifies compliance with the Australian EMC Framework regulations under the terms of the Radio Communications



Contains one or more of the 6 hazardous substances above the maximum concentration value (MCV), 40 Year EPUP.

ISM1-

This text indicates that the instrument is an Industrial Scientific and Medical Group 1 Class A product (CISPER 11, Clause 4).

ICES/
NMB
-001

This text indicates product compliance with the Canadian Interference-Causing Equipment Standard (ICES-001).

Note: *Unless otherwise indicated, this manual applies to all serial numbers.*

The Agilent Technologies 34970A/34972A combines precision measurement capability with flexible signal connections for your production and development test systems. Three module slots are built into the rear of the instrument to accept any combination of data acquisition or switching modules. The combination of data logging and data acquisition features makes this instrument a versatile solution for your testing requirements now and in the future.

Convenient Data Logging Features

- Direct measurement of thermocouples, RTDs, thermistors, DC voltage, AC voltage, resistance, DC current, AC current, frequency, and period
- Interval scanning with storage of up to 50,000 time-stamped readings
- Independent channel configuration with function, Mx+B scaling, and alarm limits available on a per-channel basis
- Intuitive user interface with knob for quick channel selection, menu navigation, and data entry from the front panel
- Portable, ruggedized case with non-skid feet
- *BenchLink Data Logger 3 Software* for Microsoft® Windows® included

Flexible Data Acquisition/Switching Features

- 6½-digit multimeter accuracy, stability, and noise rejection
- Up to 60 channels per instrument (120 single-ended channels)
- Reading rates up to 500 readings per second on a single channel and scan rates up to 250 channels per second
- Choice of multiplexing, matrix, general-purpose Form C switching, RF switching, digital I/O, totalize, and 16-bit analog output functions
- GPIB (IEEE-488) interface and RS-232 interface are standard on the 34970A. Local Area Network (LAN) and Universal Serial Bus (USB) are standard on the 34972A.
- SCPI (*Standard Commands for Programmable Instruments*) compatibility

Agilent 34970A/34972A Data Acquisition/Switch Unit

The Front Panel at a Glance

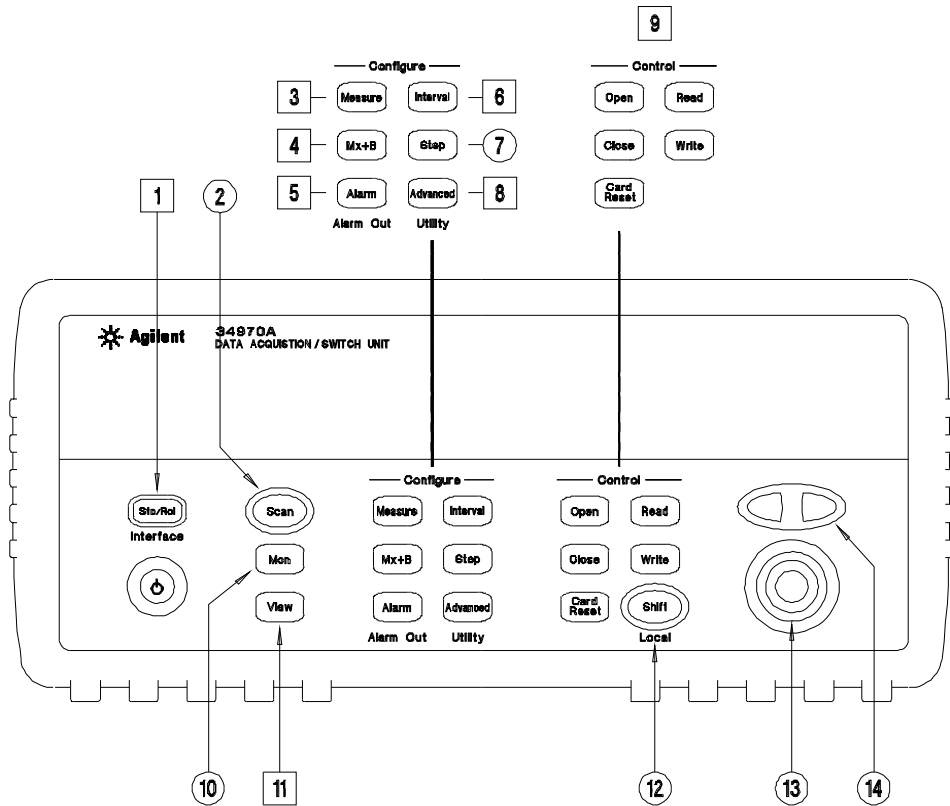

□ Denotes a menu key. See the next page for details on menu operation.

- | | |
|---|---|
| 1 State Storage / Remote Interface Menus | 8 Advanced Measurement / Utility Menus |
| 2 Scan Start / Stop Key | 9 Low-Level Module Control Keys |
| 3 Measurement Configuration Menu | 10 Single-Channel Monitor On / Off Key |
| 4 Scaling Configuration Menu | 11 View Scanned Data, Alarms, Errors Menu |
| 5 Alarm / Alarm Output Configuration Menu | 12 Shift / Local Key |
| 6 Scan-to-Scan Interval Menu | 13 Knob |
| 7 Scan List Single Step / Read Key | 14 Navigation Arrow Keys |

The Front-Panel Menu at a Glance

Several of the front-panel keys guide you through menus to configure various parameters of the instrument (see previous page). The following steps demonstrate the menu structure using the **Sto/Rcl** key.

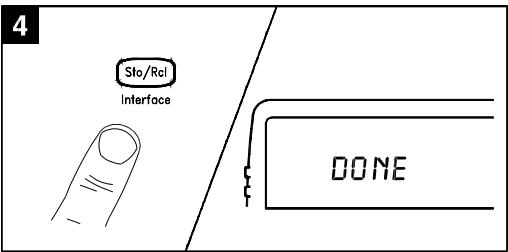
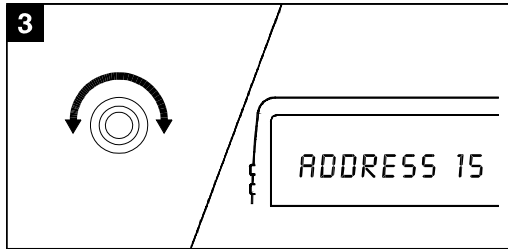
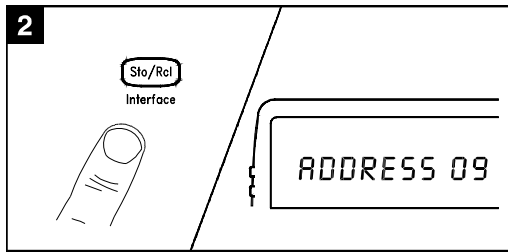
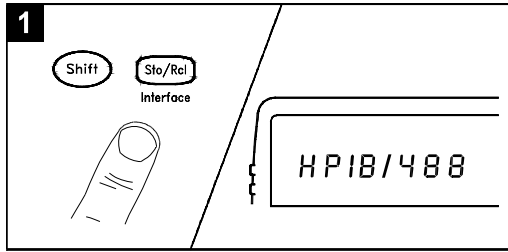

1. Press the menu key. You are automatically guided to the first level of the menu. Rotate the knob to view the other choices on the first level of the menu.

The menu will automatically time out after about 20 seconds of inactivity. You will be returned to the operation in progress prior to entering the menu.

2. Press the *same* menu key again to move to the next item of the menu. Typically, this is where you choose parameter values for the selected operation.
3. Rotate the knob to view the choices on this level of the menu. When you reach the end of the list, rotate the knob in the opposite direction to view all of the other choices.



The current selection is highlighted for emphasis. All other choices are dimmed.

4. Press the *same* menu key again to accept the change and exit the menu. A brief confirmation message is displayed.

Tip: To review the current configuration of a specific menu, press the menu key several times. A message **NO CHANGES** is displayed when you exit the menu.

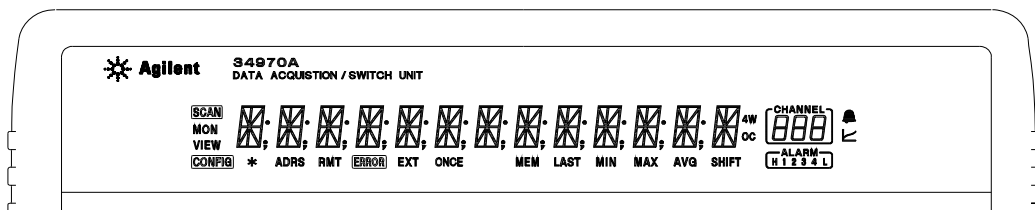
Display Annunciators



SCAN	Scan is in progress or enabled. Press and hold Scan again to turn off.
MON	Monitor mode is enabled. Press Mon again to turn off.
VIEW	Scanned readings, alarms, errors, or relay cycles are being viewed.
CONFIG	Channel configuration is in progress on displayed channel.
✕	Measurement is in progress.
ADRS	Instrument is addressed to listen or talk over the remote interface.
RMT	Instrument is in remote mode (remote interface).
ERROR	Hardware or remote interface errors are detected. Press View to read errors.
EXT	Instrument is configured for an external scan interval.
ONCE	Scan Once mode is enabled. Press Scan to initiate and hold key to disable.
MEM (34970A)	Reading memory overflow; new readings will overwrite the oldest readings.
MEM (34972A)	A USB drive is connected to the instrument (annunciator on), or data is being written to or read from the USB drive (annunciator flashing).
AUTO (34972A)	USB logging is active.
LAST	Viewed data is the <i>last</i> reading stored during most recent scan.
MIN	Viewed data is the <i>minimum</i> reading stored during most recent scan.
MAX	Viewed data is the <i>maximum</i> reading stored during most recent scan.
SHIFT	Shift has been pressed. Press Shift again to turn off.
4W	4-wire function is in use on displayed channel.
OC	Offset compensation is enabled on displayed channel.
	Alarms are enabled on displayed channel.
	Mx+B scaling is enabled on displayed channel.
	HI or LO alarm condition has occurred on indicated alarms.

To review the display annunciators, hold down the **Shift** key as you turn on the instrument.

The 34970A Rear Panel at a Glance

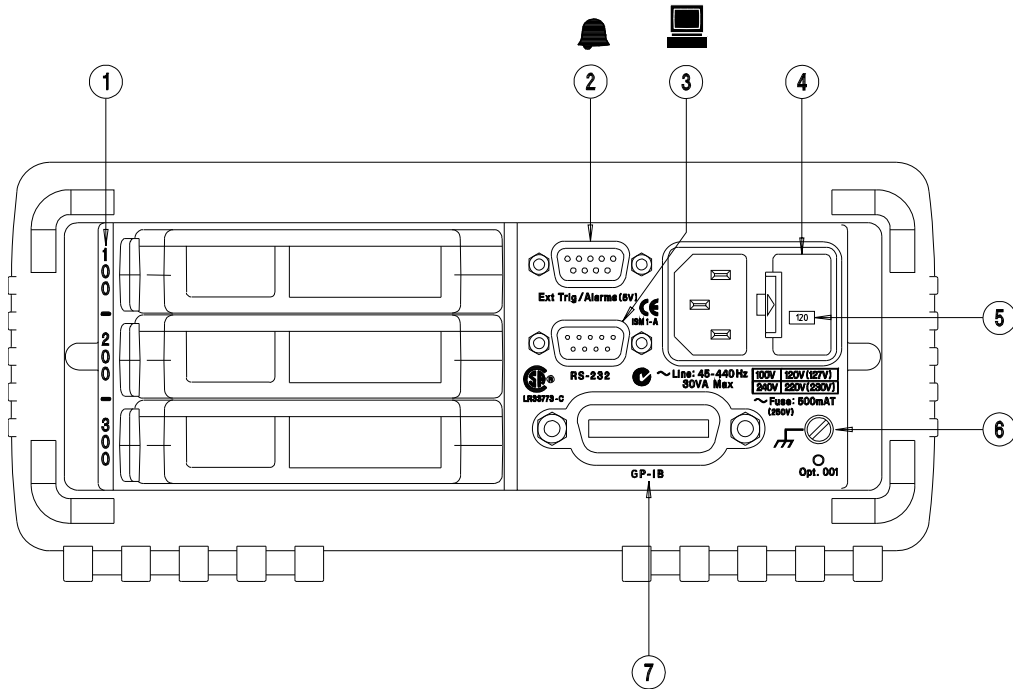

-
- | | |
|--|---------------------------------------|
| 1 Slot Identifier (100, 200, 300) | 4 Power-Line Fuse-Holder Assembly |
| 2 Ext Trig Input / Alarm Outputs / Channel Advance Input / Channel Closed Output | 5 Power-Line Voltage Setting |
| 3 RS-232 Interface Connector | 6 Chassis Ground Screw |
| | 7 GPIB (IEEE-488) Interface Connector |

Use the  **Menu to:**

- Select the GPIB or RS-232 interface (see chapter 2).
- Set the GPIB address (see chapter 2).
- Set the RS-232 baud rate, parity, and flow control mode (see chapter 2).

WARNING

For protection from electrical shock, the power cord ground must not be defeated. If only a two-contact electrical outlet is available, connect the instrument's chassis ground screw (see above) to a good earth ground.

The 34972A Rear Panel at a Glance

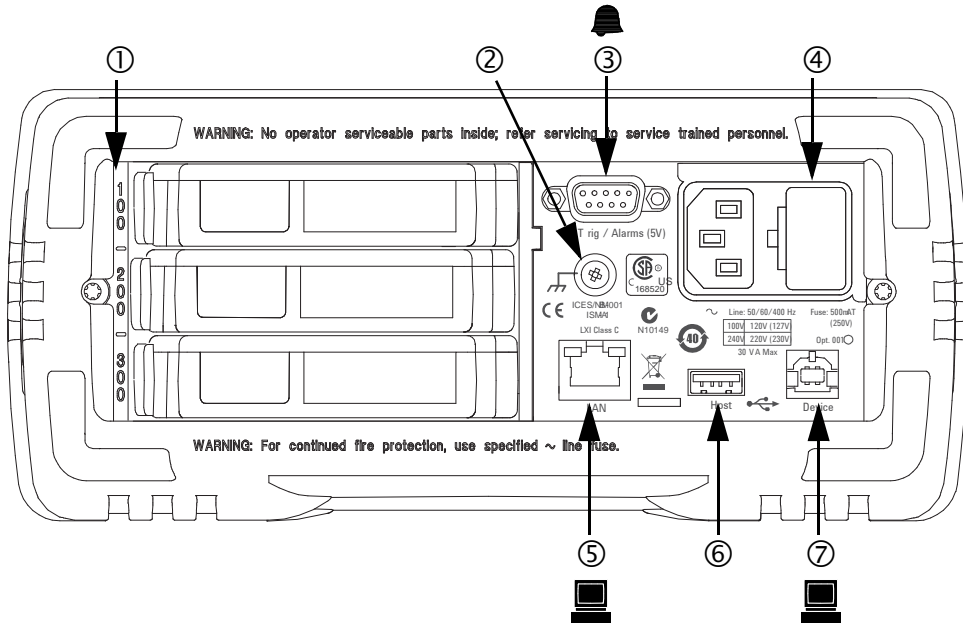

- | | |
|--|-----------------------------------|
| 1 Slot Identifier (100, 200, 300) | 4 Power-Line Fuse-Holder Assembly |
| 2 Chassis Ground Screw | 5 LAN Connector |
| 3 Ext Trig Input / Alarm Outputs / Channel Advance Input / Channel Closed Output | 6 USB Drive Connector |
| | 7 USB Interface Connector |

Use the Menu to:

- Select and configure the LAN and USB interfaces (see chapter 2).

WARNING

For protection from electrical shock, the power cord ground must not be defeated. If only a two-contact electrical outlet is available, connect the instrument's chassis ground screw (see above) to a good earth ground.

The Plug-In Modules at a Glance

For complete specifications on each plug-in modules, refer to the module sections in chapter 8.



34901A 20-Channel Armature Multiplexer

- 20 channels of 300 V switching
- Two channels for DC or AC current measurements (100 nA to 1A)
- Built-in thermocouple reference junction
- Switching speed of up to 60 channels per second
- Connects to the internal multimeter
- *For detailed information and a module diagram, see page 152.*

Each of the 20 channels switches both HI and LO inputs, thus providing fully isolated inputs to the internal multimeter. The module is divided into two banks of 10 two-wire channels each. When making four-wire resistance measurements, channels from *Bank A* are automatically paired with channels from *Bank B*. Two additional fused channels are included on the module (22 channels total) for making calibrated DC or AC current measurements with the internal multimeter (external shunt resistors are not required). You can close multiple channels on this module *only* if you have not configured any channels to be part of the scan list. Otherwise, all channels on the module are break-before-make.

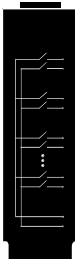

34902A 16-Channel Reed Multiplexer

- 16 channels of 300 V switching
- Built-in thermocouple reference junction
- Switching speed of up to 250 channels per second
- Connects to the internal multimeter
- *For detailed information and a module diagram, see page 154.*

Use this module for high-speed scanning and high-throughput automated test applications. Each of the 16 channels switches both HI and LO inputs, thus providing fully isolated inputs to the internal multimeter. The module is divided into two banks of eight two-wire channels each. When making four-wire resistance measurements, channels from *Bank A* are automatically paired with channels from *Bank B*. You can close multiple channels on this module *only* if you have not configured any channels to be part of the scan list. Otherwise, all channels on the module are break-before-make.

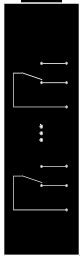

34903A 20-Channel Actuator / General-Purpose Switch

- 300 V, 1 A actuation and switching
- SPDT (Form C) latching relays
- Breadboard area for custom circuits
- *For detailed information and a module diagram, see page 156.*

Use this module for those applications that require high-integrity contacts or quality connections of non-multiplexed signals. This module can switch 300 V, 1 A (50 W maximum switch power) to your device under test or to actuate external devices. Screw terminals on the module provide access to the Normally-Open, Normally-Closed, and Common contacts for each of the 20 switches. A breadboard area is provided near the screw terminals to implement custom circuitry, such as simple filters, snubbers, or voltage dividers.

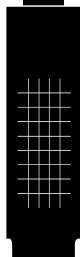

34904A 4x8 Two-Wire Matrix Switch

- 32 two-wire crosspoints
- Any combination of inputs and outputs can be connected at a time
- 300 V, 1 A switching
- *For detailed information and a module diagram, see page 157.*

Use this module to connect multiple instruments to multiple points on your device under test at the same time. You can connect rows and columns between multiple modules to build larger matrices such as 8x8 and 4x16, with up to 96 crosspoints in a single mainframe.

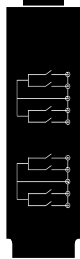

34905/6A Dual 4-Channel RF Multiplexers

- 34905A (50Ω) / 34906A (75Ω)
- 2 GHz bandwidth with on-board SMB connections
- 1 GHz bandwidth with SMB-to-BNC adapter cables provided
- *For detailed information and a module diagram, see page 158.*

These modules offer wideband switching capabilities for high frequency and pulsed signals. Each module is organized in two independent banks of 4-to-1 multiplexers. Both modules offer low crosstalk and excellent insertion loss performance. To create larger RF multiplexers, you can cascade multiple banks together. Only one channel in each bank may be closed at a time.

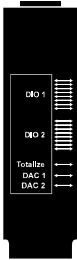

34907A Multifunction Module

- Two 8-bit Digital Input/Output ports, 400 mA sink, 42 V open collector
- 100 kHz Totalize input with 1 V_{pp} sensitivity
- Two 16-bit, ±12 V Calibrated Analog Outputs
- *For detailed information and module block diagrams, see page 161.*

Use this module to sense status and control external devices such as solenoids, power relays, and microwave switches. For greater flexibility, you can read digital inputs and the count on the totalizer during a scan.

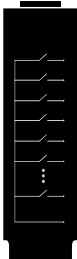

34908A 40-Channel Single-Ended Multiplexer

- 40 channels of 300 V single-ended (common LO) switching
- Built-in thermocouple reference junction
- Switching speed of up to 60 channels per second
- Connects to the internal multimeter
- *For detailed information and a module diagram, see page 159.*

Use this module for high-density switching applications which require single-wire inputs with a common LO. All relays are break-before-make to ensure that only one relay is connected at any time.

In This Book

Specifications Chapter 1 lists the technical specifications for the mainframe and plug-in modules.

Quick Start Chapter 2 helps you get familiar with a few of the instrument's front-panel features.

Front-Panel Overview Chapter 3 introduces you to the front-panel menus and describes some of the instrument's menu features.

Calibration Procedures Chapter 4 provides calibration, verification, and adjustment procedures for the instrument.

Theory of Operation Chapter 5 describes block and circuit level theory related to the operation the instrument.

Service Chapter 6 provides guidelines for returning your instrument to Agilent Technologies for servicing, or for servicing it yourself. It also contains a list of replaceable parts.



If you have questions relating to the operation of the 34970A/34972A, call 1-800-452-4844 in the United States, or contact your nearest Agilent Technologies Sales Office.

If your 34970A/34972A fails within one year of original purchase, Agilent will replace it free of charge. Call 1-800-829-4444 and select "Option 3" followed by "Option 1".

Contents

Chapter 1 Specifications

DC, Resistance, and Temperature Accuracy Specifications	22
DC Measurement and Operating Characteristics	23
AC Accuracy Specifications	24
AC Measurement and Operating Characteristics	25
System Characteristics	26
System Speed Specifications [1]	27
System Speed Specifications	28
Module Specifications	29
Module Specifications	30
Typical AC Performance Graphs	31
Module Specifications	32
Product and Module Dimensions	33
To Calculate Total Measurement Error	34
Interpreting Internal DMM Specifications	36
Configuring for Highest Accuracy Measurements	39

Chapter 2 Quick Start

To Prepare the Instrument for Use	43
To Connect Wiring to a Module	44
To Set the Time and Date	46
To Configure a Measurement Channel	47
To Monitor a Single Channel	48
To Close a Channel	49
If the Instrument Does Not Turn On	50
To Adjust the Carrying Handle	52
To Rack Mount the Instrument	53

Chapter 3 Front-Panel Overview

Front-Panel Menu Reference	57
To Unsecure for Calibration	60
To Secure Against Calibration	61
To Change the Security Code	62
Error Messages	62
To Perform a Zero Adjustment	63
To Apply Mx+B Scaling to Measurements	64
To Read the Relay Cycle Count	65
To Read a Digital Input Port	66
To Write to a Digital Output Port	67
To Read the Totalizer Count	68
To Output a DC Voltage	69

Chapter 4 Calibration Procedures

Agilent Technologies Calibration Services	73
Calibration Interval	73
Adjustment is Recommended	73
Time Required for Calibration	74
Automating Calibration Procedures	74
Recommended Test Equipment	75
Input Connections	76
Calibration Security	77
To Unsecure the Instrument Without the Security Code	78
Calibration Message	79
Calibration Count	79
Calibration Procedure	80
Aborting a Calibration in Progress	80
Test Considerations	81
Performance Verification Tests	82
Self-Test	83
Quick Performance Check	84
Performance Verification Tests	84
Internal DMM Verification Tests	85
Zero Offset Verification	85
Gain Verification	87
Optional AC Performance Verification Tests	90
Internal DMM Adjustments	91
Zero Adjustment	91

Contents

Gain Adjustment	92
-10 VDC Adjustment Procedure (Optional)	95
Plug-in Module Test Considerations	97
Relay Verification	98
Relay Cycle Count	98
34901A Relay Contact Resistance Verification	99
34902A Relay Contact Resistance Verification	106
34903A Relay Contact Resistance Verification	111
34904A Relay Contact Resistance Verification	112
34905/06A Relay Contact Resistance Verification	115
34908A Relay Contact Resistance Verification	116
Thermocouple Reference Junction (Optional)	122
Thermocouple Reference Junction Verification	122
Thermocouple Reference Junction Adjustments	123
34907A Analog Output	124
Analog Output Verification Test	124
Analog Output Adjustment	125

Chapter 5 Theory of Operation

System Block Diagram	129
Floating Logic	130
Memory	133
Earth-Referenced Logic	134
Power Supplies	135
Front Panel	137
Backplane	138
Analog Bus	138
Digital Bus	138
Internal DMM	139
DMM Block Diagram	139
Input	140
Input Amplifier	141
Ohms Current Source	143
AC Circuit	144
A-to-D Converter	146
Switch Modules	148
Switch Module Control	148
Relay Drivers	150
34901A	152

Contents

34902A	154
34903A	156
34904A	157
34905A/34906A	158
34908A	159
Multifunction Module	161
Multifunction Control	161
Totalizer	163
Analog Output	164
Digital I/O	165

Chapter 6 Service

Operating Checklist	169
Is the instrument inoperative?	169
Does the instrument fail self-test?	169
Is the Current measurement function inoperative?	169
Types of Service Available	170
Agilent Unit Exchange	170
Repackaging for Shipment	171
Cleaning	171
Electrostatic Discharge (ESD) Precautions	172
Surface Mount Repair	172
To Replace the Power-Line Fuse	173
Troubleshooting Hints	173
Unit is Inoperative	173
Unit Reports Error 705	174
Isolating to an Assembly	174
Unit Fails Self-Test	174
Power Supplies	175
Self-Test Procedures	177
Power-On Self-Test	177
Complete Self-Test	177
Plug-in Module Self-Test	177
Self-Tests	178
Disassembly	183
General Disassembly	184
Internal DMM Disassembly	185
Front Panel Disassembly	186
Additional Chassis Disassembly	187

Contents

Plug-In Module Disassembly	188
Recyclable Parts	189
Replaceable Parts	192
To Order Replaceable Parts	192
Parts List for 34970A/34972A and 34901A	193

- DC, Resistance, and Temperature Accuracy Specifications, *on page 22*
- DC Measurement and Operating Characteristics, *on page 23*
- AC Accuracy Specifications, *on page 24*
- AC Measurement and Operating Characteristics, *on page 25*
- System Characteristics, *on page 26*
- Module Specifications - 34901A, 34902A, 34908A, 34903A, 34904A, *on page 29*
- Module Specifications - 34905A, 34906A, *on page 30*
- Typical AC Performance Graphs - 34905A, 34906A, *on page 31*
- Module Specifications - 34907A, *on page 32*
- BenchLink Data Logger 3 Software Specifications, *on page 32*
- Product and Module Dimensions, *on page 33*
- To Calculate Total Measurement Error, *on page 34*
- Interpreting Internal DMM Specifications, *on page 36*
- Configuring for Highest Accuracy Measurements, *on page 39*

Specifications

■ DC, Resistance, and Temperature Accuracy Specifications

± (% of reading + % of range) ^[1]

Includes measurement error, switching error, and transducer conversion error

Function	Range ^[3]	Test Current or Burden Voltage	24 Hour ^[2] 23 °C ± 1 °C	90 Day 23 °C ± 5 °C	1 Year 23 °C ± 5 °C	Temperature Coefficient /°C 0 °C - 18 °C 28 °C - 55 °C
DC Voltage	100.0000 mV		0.0030 + 0.0035	0.0040 + 0.0040	0.0050 + 0.0040	0.0005 + 0.0005
	1.000000 V		0.0020 + 0.0006	0.0030 + 0.0007	0.0040 + 0.0007	0.0005 + 0.0001
	10.00000 V		0.0015 + 0.0004	0.0020 + 0.0005	0.0035 + 0.0005	0.0005 + 0.0001
	100.0000 V		0.0020 + 0.0006	0.0035 + 0.0006	0.0045 + 0.0006	0.0005 + 0.0001
	300.000 V		0.0020 + 0.0020	0.0035 + 0.0030	0.0045 + 0.0030	0.0005 + 0.0003
Resistance ^[4]	100.0000 Ω	1 mA current source	0.0030 + 0.0035	0.008 + 0.004	0.010 + 0.004	0.0006 + 0.0005
	1.000000 kΩ	1 mA	0.0020 + 0.0006	0.008 + 0.001	0.010 + 0.001	0.0006 + 0.0001
	10.00000 kΩ	100 μA	0.0020 + 0.0005	0.008 + 0.001	0.010 + 0.001	0.0006 + 0.0001
	100.0000 kΩ	10 μA	0.0020 + 0.0005	0.008 + 0.001	0.010 + 0.001	0.0006 + 0.0001
	1.000000 MΩ	5 μA	0.002 + 0.001	0.008 + 0.001	0.010 + 0.001	0.0010 + 0.0002
	10.00000 MΩ	500 nA	0.015 + 0.001	0.020 + 0.001	0.040 + 0.001	0.0030 + 0.0004
	100.0000 MΩ	500nA 10 MΩ	0.300 + 0.010	0.800 + 0.010	0.800 + 0.010	0.1500 + 0.0002
DC Current <i>34901A Only</i>	10.00000 mA	< 0.1 V burden	0.005 + 0.010	0.030 + 0.020	0.050 + 0.020	0.002 + 0.0020
	100.0000 mA	<0.6 V	0.010 + 0.004	0.030 + 0.005	0.050 + 0.005	0.002 + 0.0005
	1.000000 A	<2 V	0.050 + 0.006	0.080 + 0.010	0.100 + 0.010	0.005 + 0.0010
Temperature	Type	1-Year Best Range Accuracy ^[5]		Extended Range Accuracy ^[5]		Temperature Coefficient /°C
Thermocouple ^[6]	B	1100°C to 1820°C	1.2°C	400°C to 1100°C	1.8°C	0.03°C
	E	-150°C to 1000°C	1.0°C	-200°C to -150°C	1.5°C	0.03°C
	J	-150°C to 1200°C	1.0°C	-210°C to -150°C	1.2°C	0.03°C
	K	-100°C to 1200°C	1.0°C	-200°C to -100°C	1.5°C	0.03°C
	N	-100°C to 1300°C	1.0°C	-200°C to -100°C	1.5°C	0.03°C
	R	300°C to 1760°C	1.2°C	-50°C to 300°C	1.8°C	0.03°C
	S	400°C to 1760°C	1.2°C	-50°C to 400°C	1.8°C	0.03°C
	T	-100°C to 400°C	1.0°C	-200°C to -100°C	1.5°C	0.03°C
RTD	R ₀ from 49Ω to 2.1 kΩ	-200°C to 600°C	0.06°C			0.003°C
Thermistor	2.2 k, 5 k, 10 k	-80°C to 150°C	0.08°C			0.002°C

[1] Specifications are for 1 hour warm up and 6½ digits, slow AC filter.

[2] Relative to calibration standards.

[3] 20% over range on all ranges except 300 VDC and 1 Adc ranges.

[4] Specifications are for 4-wire ohms function or 2-wire ohms using Scaling to remove the offset.

Without Scaling, add 4Ω additional error in 2-wire ohms function.

[5] 1 year accuracy. For total measurement accuracy, add temperature probe error.

[6] Thermocouple specifications are not guaranteed when 34907A module is present.

DC Measurement and Operating Characteristics

DC Measurement Characteristics ^[1]

DC Voltage	
Measurement Method:	Continuously Integrating Multi-slope III A/D Converter
A/D Linearity:	0.0002% of reading + 0.0001% of range
Input Resistance:	Selectable 10 M Ω or > 10 G Ω
100 mV, 1V, 10 V ranges	10 M Ω \pm 1%
100 V, 300 V ranges	
Input Bias Current:	< 30 pA at 25 $^{\circ}$ C
Input Protection:	300 V on all ranges
Resistance	
Measurement Method:	Selectable 4-wire or 2-wire Ohms Current source reference to LO input
Offset compensation:	Selectable on 100 Ω , 1k Ω , 10k Ω ranges
Max. Lead Resistance:	10% of range per lead for 100 Ω and 1 k Ω ranges. 1 k Ω on all other ranges
Input Protection:	300 V on all ranges
DC Current	
Shunt Resistance:	5 Ω for 10 mA, 100 mA; 0.1 Ω for 1A.
Input Protection:	1.5A 250 V fuse on 34901A module
Thermocouple	
Conversion:	ITS-90 software compensation
Reference Junction Type:	Internal, Fixed, or External
Open T/C Check:	Selectable per channel. Open > 5 k Ω
RTD	α - 0.00385 (DIN/IEC 751) using ITS-90 software compensation or α = 0.00391 using IPTS-68 software compensation.
Thermistor	44004, 44007, 44006 series
Measurement Noise Rejection 60 Hz (50 Hz) ^[2]	
DC CMRR:	140 dB
Integration Time	
200 PLC / 3.33s (4s)	110 dB ^[4]
100 PLC / 1.67s (2s)	105 dB ^[4]
20 PLC / 333 ms (400 ms)	100 dB ^[4]
10 PLC / 167 ms (200 ms)	95 dB ^[4]
2 PLC / 33.3 ms (40 ms)	90 dB
1 PLC / 16.7 ms (20 ms)	60 dB
< 1PLC	0 dB
Normal Mode Rejection ^[3]	

DC Operating Characteristics ^[5]

Function	Digits ^[6]	Readings/s	Additional Noise Error
DCV, DCI, and Resistance:	6½	0.6 (0.5)	0% of range
	6½	6 (5)	0% of range
	5½	60 (50)	0.001% of range
	5½	300	0.001% of range ^[7]
	4½	600	0.01% of range ^[7]

Single Channel Measurement Rates ^[8]

Function	Resolution	Readings/s
DCV, 2-Wire Ohms:	6½ (10 PLC)	6 (5)
	5½ (1 PLC)	54 (47)
	4½ (0.02 PLC)	500
Thermocouple:	0.1 $^{\circ}$ C (10 PLC)	6 (5)
	0.1 $^{\circ}$ C (1 PLC)	52 (47)
	(0.02 PLC)	280
RTD, Thermistor:	0.01 $^{\circ}$ C (10 PLC)	6 (5)
	0.1 $^{\circ}$ C (1 PLC)	49 (47)
	1 $^{\circ}$ C (0.02 PLC)	200

Autozero OFF Operation

Following instrument warm-up at calibration temperature \pm 1 $^{\circ}$ C and < 10 minutes, add 0.0002% range additional error + 5 μ V.

Settling Consideration

Reading settling times are affected by source impedance, low dielectric absorption characteristics, and input signal changes.

[1] Isolation voltage (ch-ch, ch-earth) 300 VDC, AC rms

[2] For 1 k Ω unbalance in LO lead

[3] For power line frequency \pm 0.1%

[4] For power line frequency \pm 1%, use 80 dB

For power line frequency \pm 3%, use 60 dB

[5] Reading speeds for 60 Hz and (50 Hz) operation; autozero OFF

[6] 6½ digits=22 bits, 5½ digits=18 bits, 4½ digits=15 bits

[7] Add 20 μ V for DCV, 4 μ A for DCI, or 20 m Ω for resistance

[8] For fixed function and range, readings to memory, scaling and alarms off, autozero OFF

Chapter 1 Specifications
AC Accuracy Specifications

■ **AC Accuracy Specifications**

± (% of reading + % of range) ^[1]
Includes measurement error, switching error, and transducer conversion error

Function	Range ^[3]	Frequency	24 Hour ^[2] 23 °C ± 1 °C	90 Day 23 °C ± 5 °C	1 Year 23 °C ± 5 °C	Temperature Coefficient /°C 0 °C - 18 °C 28 °C - 55 °C
True RMS AC Voltage ^[4]	100.0000 mV to 100 V	3 Hz - 5 Hz 5 Hz - 10 Hz 10 Hz - 20 kHz 20 kHz - 50 kHz 50 kHz - 100 kHz 100 kHz - 300 kHz ^[5]	1.00 + 0.03 0.35 + 0.03 0.04 + 0.03 0.10 + 0.05 0.55 + 0.08 4.00 + 0.50	1.00 + 0.04 0.35 + 0.04 0.05 + 0.04 0.11 + 0.05 0.60 + 0.08 4.00 + 0.50	1.00 + 0.04 0.35 + 0.04 0.06 + 0.04 0.12 + 0.05 0.60 + 0.08 4.00 + 0.50	0.100 + 0.004 0.035 + 0.004 0.005 + 0.004 0.011 + 0.005 0.060 + 0.008 0.20 + 0.02
	300.0000 V	3 Hz - 5 Hz 5 Hz - 10 Hz 10 Hz - 20 kHz 20 kHz - 50 kHz 50 kHz - 100 kHz 100 kHz - 300 kHz ^[5]	1.00 + 0.05 0.35 + 0.05 0.04 + 0.05 0.10 + 0.10 0.55 + 0.20 4.00 + 1.25	1.00 + 0.08 0.35 + 0.08 0.05 + 0.08 0.11 + 0.12 0.60 + 0.20 4.00 + 1.25	1.00 + 0.08 0.35 + 0.08 0.06 + 0.08 0.12 + 0.12 0.60 + 0.20 4.00 + 1.25	0.100 + 0.008 0.035 + 0.008 0.005 + 0.008 0.011 + 0.012 0.060 + 0.020 0.20 + 0.05
Frequency and Period ^[6]	100 mV to 300 V	3 Hz - 5 Hz 5 Hz - 10 Hz 10 Hz - 40 Hz 40 Hz - 300 kHz	0.10 0.05 0.03 0.006	0.10 0.05 0.03 0.01	0.10 0.05 0.03 0.01	0.005 0.005 0.001 0.001
True RMS AC Current <i>34901A Only</i>	10.00000 mA ^[4] and 1.000000 A ^[4]	3 Hz - 5 Hz 5 Hz - 10 Hz 10 Hz - 5 kHz	1.00 + 0.04 0.30 + 0.04 0.10 + 0.04	1.00 + 0.04 0.30 + 0.04 0.10 + 0.04	1.00 + 0.04 0.30 + 0.04 0.10 + 0.04	0.100 + 0.006 0.035 + 0.006 0.015 + 0.006
	100.0000 mA ^[7]	3 Hz - 5 Hz 5 Hz - 10 Hz 10 Hz - 5 kHz	1.00 + 0.5 0.30 + 0.5 0.10 + 0.5	1.00 + 0.5 0.30 + 0.5 0.10 + 0.5	1.00 + 0.5 0.30 + 0.5 0.10 + 0.5	0.100 + 0.06 0.035 + 0.06 0.015 + 0.06

Additional Low Frequency Error for ACV, ACI (% of reading)				Additional Error for Frequency, Period (% of reading)			
Frequency	AC Filter Slow	AC filter Medium	AC Filter Fast	Frequency	6½ Digits	5½ Digits	4½ Digits
10 Hz - 20 Hz	0	0.74	--	3 Hz - 5 Hz	0	0.12	0.12
20 Hz - 40 Hz	0	0.22	--	5 Hz - 10 Hz	0	0.17	0.17
40 Hz - 100 Hz	0	0.06	0.73	10 Hz - 40 Hz	0	0.2	0.2
100 Hz - 200 Hz	0	0.01	0.22	40 Hz - 100 Hz	0	0.06	0.21
200 Hz - 1 kHz	0	0	0.18	100 Hz - 300 Hz	0	0.03	0.21
> 1 kHz	0	0	0	300 Hz - 1 kHz	0	0.01	0.07
				>1 kHz	0	0	0.02

[1] Specifications are for 1 hour warm up and 6½ digits, Slow AC filter
[2] Relative to calibration standards
[3] 20% over range on all ranges except 300 VAC and 1 A ac ranges and AC current ranges.
[4] For sinewave input >5% of range. For inputs from 1% to 5% of range and <50 kHz, add 0.1% of range additional error.
[5] Typically 30% of reading error at 1 MHz, limited to 1x10⁸ V Hz
[6] Input > 100 mV. For 10 mV to 100 mV inputs, multiply % of reading error x 10.
[7] Specified only for inputs > 10 mA

AC Measurement and Operating Characteristics

AC Measurement Characteristics ^[1]	
True RMS AC Voltage	
Measurement Method:	AC-coupled True RMS -measures the AC component of input with up to 300 VDC of bias on any range
Crest Factor:	Maximum 5:1 at Full Scale
Additional Crest Factor Errors (non-sinewave): ^[2]	Crest Factor 1-2: 0.05% of reading Crest Factor 2-3: 0.15% of reading Crest Factor 3-4: 0.30% of reading Crest Factor 4-5: 0.40% of reading
AC Filter Bandwidth:	
Slow	3 Hz - 300 kHz
Medium	20 Hz - 300 kHz
Fast	200 Hz - 300 kHz
Input Impedance:	1 M Ω \pm 2%, in parallel with 150 pF
Input Protection:	300 Vrms on all ranges
Frequency and Period	
Measurement Method:	Reciprocal counting technique
Voltage Ranges:	Same as AC Voltage function
Gate Time:	1s, 100 ms, or 10 ms
Measurement Timeout:	Selectable 3 Hz, 20 Hz, 200 Hz LF limit
True RMS AC Current	
Measurement Method:	Direct coupled to the fuse and shunt. AC-coupled True RMS measurement (measures the AC component only)
Shunt Resistance:	5 Ω for 10 mA; 0.1 Ω for 100 mA, 1A
Input Protection:	1.5A 250 V fuse on 34901A module
Measurement Noise Rejection ^[3]	
AC CMRR:	70 dB
Measurement Considerations (Frequency and Period)	
All frequency counters are susceptible to error when measuring low-voltage, low-frequency signals. Shielding inputs from external noise pickup is critical for minimizing measurement errors.	

AC Operating Characteristics ^[4]			
Function	Digits ^[5]	Readings/s	AC Filter
ACV, ACI:	6½	7 sec/reading	Slow (3 Hz)
	6½	1	Medium (20 Hz)
	6½	8 ^[6]	Fast (200 Hz)
	6½	10	Fast (200 Hz)
	6½	100 ^[7]	Fast (200 Hz)
Single Channel Measurement Rates ^[8]			
Function	Resolution	Readings/s	
ACV:	6½ Slow (3 Hz)	0.14	
	6½ Medium (20 Hz)	1	
	6½ Fast (200 Hz)	8	
	6½ ^[7]	100	
Frequency, Period:	6½ Digits (1s gate)	1	
	5½ Digits (100 ms)	9	
	4½ Digits (10 ms)	70	

- [1] Isolation voltage (ch-ch, ch-earth) 300 VDC, AC rms
- [2] For frequencies below 100 Hz, slow AC filter specified for sinewave input only
- [3] For 1 k Ω unbalance in LO lead
- [4] Maximum reading rates for 0.01% of AC step additional error. Additional settling delay required when input DC level varies.
- [5] 6½ digits=22 bits, 5½ digits=18 bits, 4½ digits=15 bits
- [6] For external trigger or remote operation using default settling delay (Delay Auto)
- [7] Maximum limit with default settling delays defeated
- [8] For fixed function and range, readings to memory, scaling and alarms turned off.

Chapter 1 Specifications

System Characteristics

■ System Characteristics

System Characteristics	
Scan Triggering	
Scan Count:	1 to 50,000 or continuous
Scan Interval:	0 to 99 hours; 1 ms step size
Channel Delay:	0 to 60 seconds/channel; 1 ms step size
External Trig Delay:	< 300 μ s; With Monitor On, < 200 ms
External Trig Jitter:	< 2 ms
Alarms	
Alarm Outputs:	4 TTL compatible. Selectable TTL logic HI or LO on Fail
Latency:	5 ms (typical)
Memory	
	Battery Backed, 34970A - 4 year typical life ^[1] 34972A - User-replaceable battery, recommended replacement during yearly calibration.
Readings:	50,000 internal readings with timestamp, readable during scan.
Time Stamp Resolution:	
Relative	1 ms
Absolute	1 s
States:	5 instrument states
Alarm Queue:	Up to 20 events
USB Drive:	FAT or FAT32 format
General Specifications	
Power Supply:	100 V / 120 V / 220 V/240 V \pm 10%
Power Line Frequency:	45 Hz to 60 Hz automatically sensed
Power Consumption:	(12 W) 25 VA peak
Operating Environment:	Full accuracy for 0 °C to 55 °C Full accuracy to 80% R.H. at 40 °C
Storage Environment:	-40 °C to 70 °C ^[1]
Weight (Mainframe):	Net: 3.6 kg (8.0 lbs)
Safety:	Conforms to CSA, US-1244, IEC 1010 CAT I
RFI and ESD:	CISPR 11, IEC 801/2/3/4
Warranty:	1 year

[1] Storage at temperatures above 40 °C will decrease battery life.

*This ISM device complies with Canadian ICES-001.
Cet appareil ISM est conforme à norme NMB-001 du Canada.*



N10149

■ System Speed Specifications [1]

Single Channel Reading Rates to I/O or internal memory	34970A		34972A
	into Memory	to GPIB or RS232	to LAN, USB or Memory
	readings/sec	readings/sec	readings/sec
Single Channel ASCII dcV readings	500	440	500
Single Channel while changing scale (eg MEAS dcV 10 / MEAS dcV 1)	25	25	25
Single Channel while changing function (eg MEAS dcV / MEAS Ohms)	12	12	12
Scanning Measurement Rates to I/O or internal memory	34970A		34972A
	into Memory	to GPIB or RS232	to LAN, USB or Memory
	ch/sec	ch/sec	ch/sec
Scanning DCV or Ohms channels			
34901A/34908A	60	60	60
34902A	250	210	240
34902A into and out of memory (using INIT, FETCh)	--	180	240
34902A with timestamp (using MEAS)	--	150	240
34902A with scaling and alarms	220	190	220
34902A DCV and ohms on alternate channels	80	80	80
Scanning ACV channels [2]			
34901A/34908A	50	50	50
34902A	100	90	100
Scanning Temperature - Thermistor or T/C channels			
34901A/34908A	50	50	50
34902A	150	150	150
Scanning Digital In/Totalizer channels			
34907A Digital Input	275	250	275
34907A Totalizer	240	210	240

[1] Speeds are for 4½ digits, delay 0, display off, autozero off, unless otherwise noted. Use MEAS command for best I/O performance. RS232 at 115Kbaud.

[2] Maximum, with default delays defeated.

Chapter 1 Specifications
System Speed Specifications

System Speed Specifications

Data out of memory [3][4]	34970A		34972A	
	over GPIB	over RS232	over USB	over LAN or memory
(FETCh of 50K readings)	readings/sec	readings/sec	readings/sec	readings/sec
Readings	800	600	55K	120K
Readings with timestamp	450	320	35K	60K
Readings with all format options ON.	310	230	25K	50K

[3] Assumes relative time format (time since start of scan)

[4] Typical rates assuming lightly loaded PC and limited other traffic on I/Os. LAN rates assume use of socket connection; VX111 will be less.

[5] For fixed function and range, readings to memory, scaling/alarms/autozero off

Module Specifications

34901A, 34902A, 34908A, 34903A, 34904A

General	Multiplexer			Actuator	Matrix
	34901A	34902A	34908A	34903A	34904A
Number of Channels	20+2	16	40	20	4x8
	2/4 wire	2/4 wire	1 wire	SPDT	2 wire
Connects to Internal DMM	Yes	Yes	Yes	No	No
Scanning Speed ^[1]	60 ch/s	250 ch/s	60 ch/s		
Open/Close Speed	120/s	120/s	70/s	120/s	120/s
Maximum Input					
Voltage (dc, AC rms)	300 V	300 V	300 V	300 V	300 V
Current (dc, AC rms)	1 A	50 mA	1 A	1 A	1 A
Power (W, VA)	50 W	2 W	50W	50W	50W
Isolation (ch-ch, ch-earth) dc, AC rms	300 V	300 V	300 V	300 V	300 V
DC Characteristics					
Offset Voltage ^[2]	< 3 μ V	<6 μ V	< 3 μ V	< 3 μ V	< 3 μ V
Initial Closed Channel R ^[2]	< 1 Ω	< 1 Ω	< 1 Ω	< 0.2 Ω	< 1 Ω
Isolation (ch-ch, ch-earth)	> 10 G Ω	> 10 G Ω	> 10 G Ω	> 10 G Ω	> 10 G Ω
AC Characteristics					
Bandwidth	10 MHz	10 MHz	10 MHz	10 MHz	10 MHz
Ch-Ch Cross Talk (dB) ^[3] 10 MHz	-45	-45	-18 ^[4]	-45	-33
Capacitance HI to LO	< 50 pF	< 50 pF	< 50 pF	< 10 pF	< 50 pF
Capacitance LO to Earth	< 80 pF	< 80 pF	< 80 pF	< 80 pF	< 80 pF
Volt-Hertz Limit	10 ⁸	10 ⁸	10 ⁸	10 ⁸	10 ⁸
Other					
T/C cold Junction Accuracy ^{[2] [5]} (typical)	0.8 °C	0.8 °C	0.8 °C ^[7]		
Switch Life No Load (typical)	100M	100M	100M	100M	100M
Switch Life Rated Load (typical) ^[6]	100k	100k	100k	100k	100k
Temperature Operating	All Modules: 0 °C to 55 °C				
Temperature Storage	All Modules: -20 °C to 70 °C				
Humidity (non-condensing)	All Modules: 40 °C / 80% R.H.				

[1] See scanning rate specifications for measurement conditions and rates on each instrument.

[2] Errors included in the DMM measurement accuracy specifications

[3] 50 Ω source, 50 Ω load

[4] Isolation within channel 1 to 20 or 21 to 40 banks is -40 dB

[5] Thermocouple specifications not guaranteed when 34907A module is present

[6] Applies to resistive loads only

[7] Thermocouple measurements not recommended with 34908A module due to common LO configuration.

Chapter 1 Specifications
Module Specifications

■ **Module Specifications**
 34905A, 34906A

		RF Multiplexer	
General		34905A	34906A
Number of Channels		Dual 1x4 50Ω	Dual 1x4 75Ω
Open/Close Speed		60/s	
Maximum Input			
Voltage (dc, AC rms)		42 V	
Current (dc, AC rms)		0.7 A	
Power (W, VA)		20 W	
DC Characteristics			
Offset Voltage ^[1]		< 6 μV	
Initial Closed Channel R ^[1]		< 0.5 Ω	
Isolation (ch-ch, ch-earth)		> 1 GΩ	
Other			
Switch Life	No Load (typical)	5M	
Switch Life	Rated Load (typical) ^[2]	100k	
Temperature	Operating	0 °C to 55 °C	
Temperature	Storage	-20 °C to 70 °C	
Humidity (non-condensing)		40 °C/ 80% R.H.	

The AC performance graphs are shown on the following page.

AC Characteristics		34905A	34906A
Bandwidth ^[3]		2 GHz	2 GHz
Insertion Loss (dB)	10 MHz	-0.1	-0.1
	100 MHz	-0.4	-0.4
	500 MHz	-0.6	-0.5
	1 GHz	-1.0	-1.0
	1.5 GHz	-1.2	1.5
	2 GHz	-3.0	-2.0
SWR	10 MHz	1.02	1.02
	100 MHz	1.05	1.05
	500 MHz	1.20	1.25
	1 GHz	1.20	1.40
	1.5 GHz	1.30	1.40
	2 GHz	1.40	2.00
Ch-Ch Cross Talk (db) ^[4]	10 MHz	-100	-85
	100 MHz	-85	-75
	500 MHz	-65	-65
	1 GHz	-55	-50
	1.5 GHz	-45	-40
	2 GHz	-35	-35
Risetime		< 300 ps	
Signal Delay		< 3 ns	
Capacitance	HI to LO	<20 pF	
Volt-Hertz Limit		10 ¹⁰	

■ **Typical AC Performance Graphs**
 34905A, 34906A

Insertion Loss (50Ω)

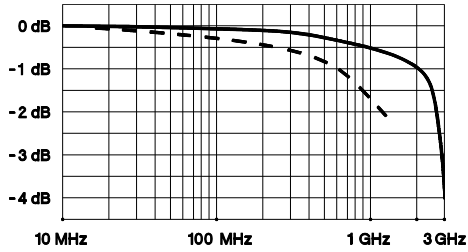

Insertion Loss (75Ω)

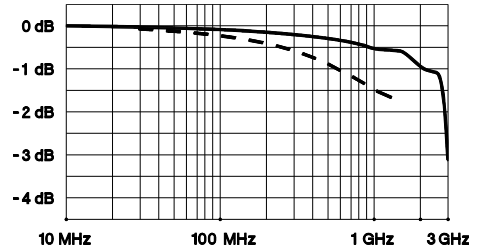

— Direct to Module
 - - - Using provided adapter cables

VSWR (50Ω)

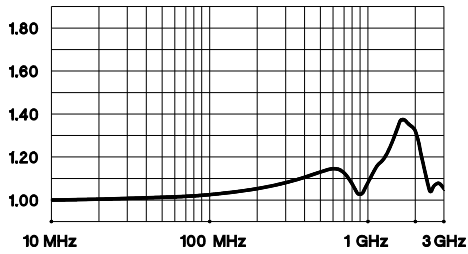

VSWR (75Ω)

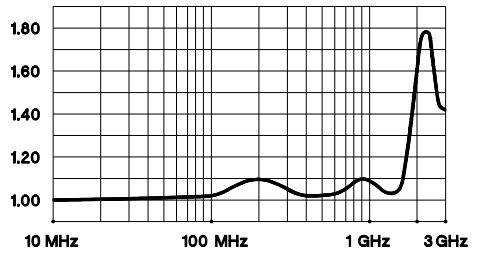

Crosstalk (50Ω)

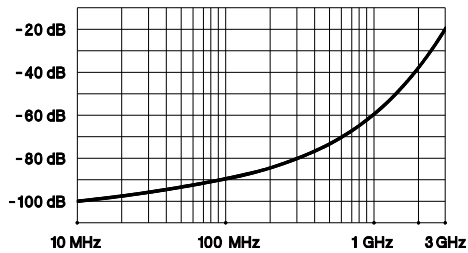

Crosstalk (75Ω)

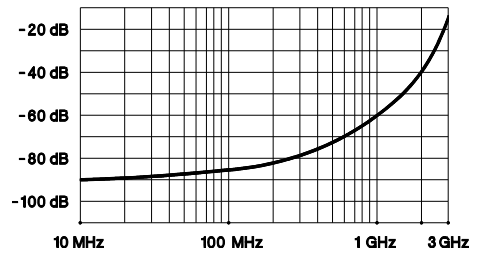

Chapter 1 Specifications
Module Specifications

■ **Module Specifications**
 34907A

Digital Input/Output	
Port 1, 2:	8 Bit, input or output, non-isolated
Vin(L):	< 0.8V (TTL)
Vin (H):	> 2.0V (TTL)
Vout(L):	< 0.8V @ Iout = -400 mA
Vout(H):	> 2.4V @ Iout = 1 mA
Vin(H) Max:	<42V with external open drain pull-up
Alarming:	Maskable pattern match or state change
Speed	4 ms (max) alarm sampling
Latency	5 ms (typical) to 34970A/34972A alarm output
Read/Write Speed:	95/s

Totalize Input	
Maximum Count:	2 ²⁶ - 1 (67,108,863)
Totalize Input:	100 kHz (max), rising or falling edge, programmable
Signal Level:	1 Vp-p (min) 42 Vpk (max)
Threshold:	0V or TTL, jumper selectable
Gate Input:	TTL-HI, TTL-LO, or none
County Reset:	Manual or Read+Reset
Read Speed:	85/s

Analog Voltage (DAC) Output	
DAC 1, 2:	±12V, non-isolated (earth referenced)
Resolution:	1 mV
Iout:	10 mA max ^[1]
Settling Time:	1 ms to 0.01% of output
Accuracy:	±(% of output + mV)
1 year ±5 °C	0.25% + 20 mV
Temp Coefficient:	±(0.015% + 1 mV) / °C

[1] Limited to 40 mA total for all three slots (six DAC channels)

■ **Software Specifications**

Agilent 34825A BenchLink Data Logger 3 <i>(included with Option DMM)</i>	
System Requirements^[2]	
Operating System	Windows Vista®, XP SP2, 2000 SP4 (does not support any home editions), Adobe® Acrobat® Reader V5.0 or higher (to view documentation) Microsoft® Internet Explorer V6.0 or higher (required when using Windows NT)
Controller	Recommend Pentium® 4, 800 MHz or greater, Min: Pentium III, 500 MHz
RAM	Recommend 256 MB or greater, Min 128 MB
Disk Space	Recommend 200MB, Min 100MB
Display	Recommend 1024x768 resolution, 256 colors
Computer Interfaces^[3]	
34970A	
GPIB	Agilent and National Instruments PCI-GPIB
RS-232 (Serial port)	PC COM 1-4
34972A	
LAN	10/100/1000 Base T
USB	USB 2.0

[2] Software provided on CD-ROM and includes utility to create floppy disks for installation

[3] Interface and driver must be purchased and installed separately

Product and Module Dimensions

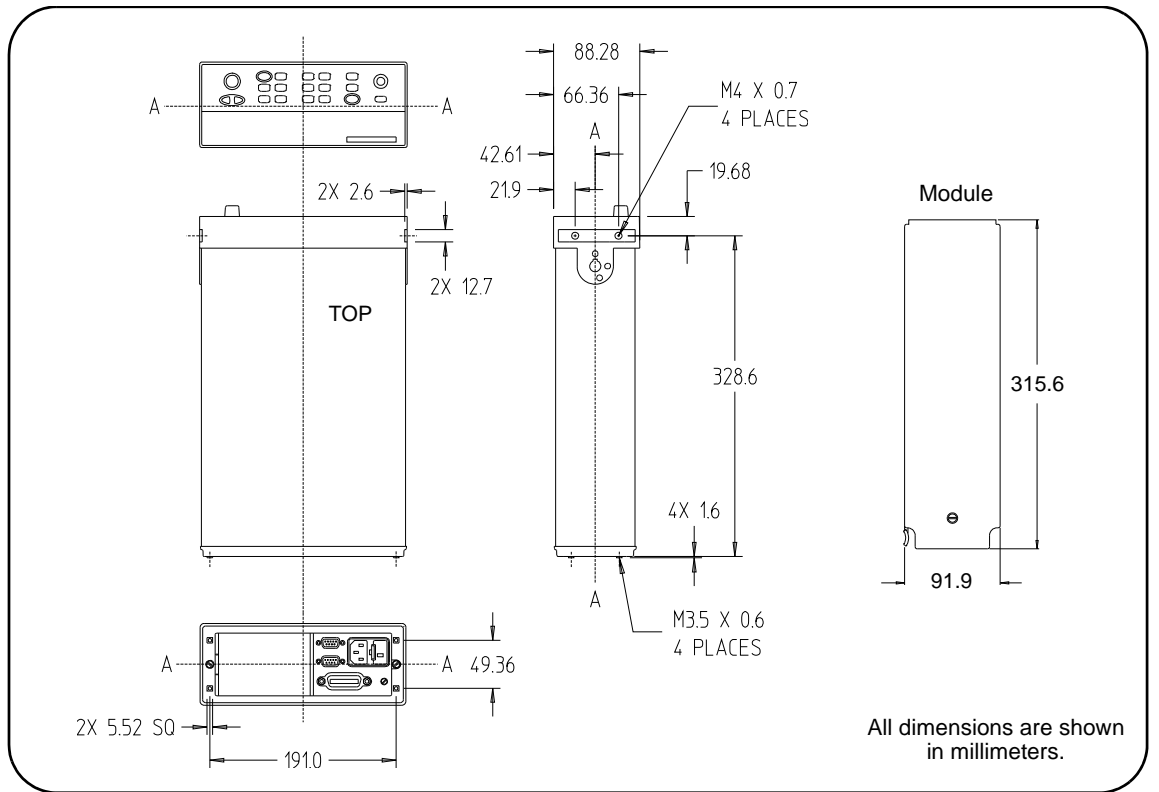
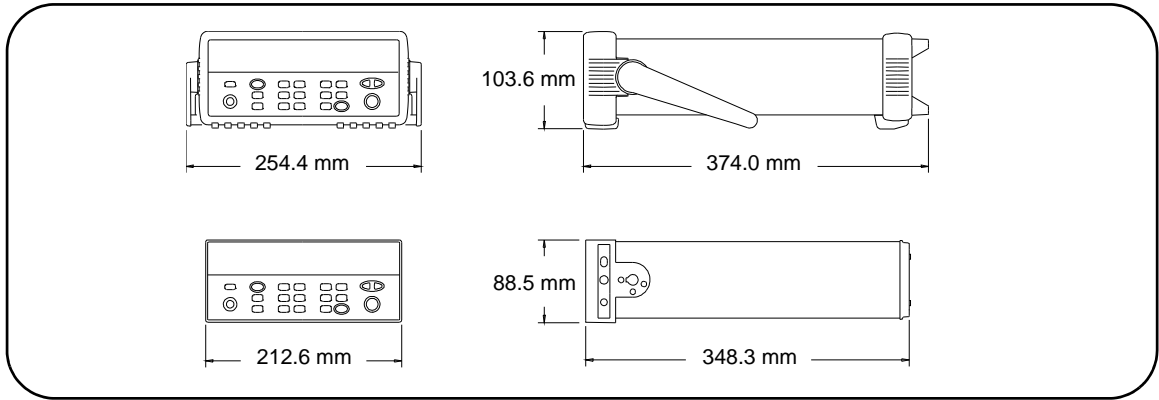

To Calculate Total Measurement Error

Each specification includes correction factors which account for errors present due to operational limitations of the internal DMM. This section explains these errors and shows how to apply them to your measurements. Refer to “*Interpreting Internal DMM Specifications*,” starting on page 36, to get a better understanding of the terminology used and to help you interpret the internal DMM’s specifications.

The internal DMM’s accuracy specifications are expressed in the form: (*% of reading + % of range*). In addition to the reading error and range error, you may need to add additional errors for certain operating conditions. Check the list below to make sure you include all measurement errors for a given function. Also, make sure you apply the conditions as described in the footnotes on the specification pages.

- If you are operating the internal DMM outside the $23\text{ }^{\circ}\text{C} \pm 5\text{ }^{\circ}\text{C}$ temperature range specified, apply an additional *temperature coefficient error*.
- For DC voltage, DC current, and resistance measurements, you may need to apply an additional *reading speed error*.
- For AC voltage and AC current measurements, you may need to apply an additional *low frequency error or crest factor error*.

Understanding the “% of reading” Error The *reading error* compensates for inaccuracies that result from the function and range you select, as well as the input signal level. The reading error varies according to the input level on the selected range. This error is expressed in percent of reading. The following table shows the reading error applied to the internal DMM’s 24-hour DC voltage specification. .

Range	Input Level	Reading Error (% of reading)	Reading Error Voltage
10 VDC	10 VDC	0.0015	$\leq 150\text{ }\mu\text{V}$
10 VDC	1 VDC	0.0015	$\leq 15\text{ }\mu\text{V}$
10 VDC	0.1 VDC	0.0015	$\leq 1.5\text{ }\mu\text{V}$

Understanding the “ % of range ” Error The *range error* compensates for inaccuracies that result from the function and range you select. The range error contributes a constant error, expressed as a percent of range, *independent* of the input signal level. The following table shows the range error applied to the DMM’s 24-hour DC voltage specification.

Range	Input Level	Reading Error (% of reading)	Range Error Voltage
10 VDC	10 VDC	0.0004	≤40 μV
10 VDC	1 VDC	0.0004	≤40 μV
10 VDC	0.1 VDC	0.0004	≤40 μV

Total Measurement Error To compute the total measurement error, add the reading error and range error. You can then convert the total measurement error to a “percent of input” error or a “ppm (part-per-million) of input” error as shown below.

$$\% \text{ of input error} = \frac{\text{Total Measurement Error}}{\text{Input Signal Level}} \times 100$$

$$\text{ppm of input error} = \frac{\text{Total Measurement Error}}{\text{Input Signal Level}} \times 1,000,000$$

Example: Computing Total Measurement Error

Assume that a 5 VDC signal is input to the DMM on the 10 VDC range. Compute the total measurement error using the 90-day accuracy specification of ±(0.0020% of reading + 0.0005% of range).

$$\begin{aligned} \text{Reading Error} &= 0.0020\% \times 5 \text{ VDC} &= 100 \mu\text{V} \\ \text{Range Error} &= 0.0005\% \times 10 \text{ VDC} &= 50 \mu\text{V} \\ \text{Total Error} &= 100 \mu\text{V} + 50 \mu\text{V} &= \pm 150 \mu\text{V} \\ & &= \pm 0.0030\% \text{ of } 5 \text{ VDC} \\ & &= \pm 30 \text{ ppm of } 5 \text{ VDC} \end{aligned}$$

Interpreting Internal DMM Specifications

This section is provided to give you a better understanding of the terminology used and will help you interpret the internal DMM's specifications.

Number of Digits and Overrange

The “number of digits” specification is the most fundamental, and sometimes, the most confusing characteristic of a multimeter. The number of digits is equal to the maximum number of “9’s” the multimeter can measure or display. This indicates the number of *full digits*. Most multimeters have the ability to overrange and add a partial or “½” digit.

For example, the internal DMM can measure 9.99999 VDC on the 10 V range. This represents six full digits of resolution. The internal DMM can also overrange on the 10 V range and measure up to a maximum of 12.00000 VDC. This corresponds to a 6½-digit measurement with 20% overrange capability.

Sensitivity

Sensitivity is the minimum level that the internal DMM can detect for a given measurement. Sensitivity defines the ability of the internal DMM to respond to small changes in the input level. For example, suppose you are monitoring a 1 mVDC signal and you want to adjust the level to within $\pm 1 \mu\text{V}$. To be able to respond to an adjustment this small, this measurement would require a multimeter with a sensitivity of at least 1 μV . You could use a 6½-digit multimeter *if* it has a 1 VDC or smaller range. You could also use a 4½-digit multimeter with a 10 mVDC range.

For AC voltage and AC current measurements, note that the smallest value that can be measured is different from the sensitivity. For the internal DMM, these functions are specified to measure down to 1% of the selected range. For example, the internal DMM can measure down to 1 mV on the 100 mV range.

Resolution

Resolution is the numeric ratio of the maximum displayed value divided by the minimum displayed value on a selected range. Resolution is often expressed in percent, parts-per-million (ppm), counts, or bits. For example, a 6½-digit multimeter with 20% overrange capability can display a measurement with up to 1,200,000 counts of resolution. This corresponds to about 0.0001% (1 ppm) of full scale, or 21 bits including the sign bit. All four specifications are equivalent.

Accuracy

Accuracy is a measure of the “exactness” to which the internal DMM’s measurement uncertainty can be determined *relative* to the calibration reference used. Absolute accuracy includes the internal DMM’s relative accuracy specification plus the known error of the calibration reference relative to national standards (such as the U.S. National Institute of Standards and Technology). To be meaningful, the accuracy specifications must be accompanied with the conditions under which they are valid. These conditions should include temperature, humidity, and time.

There is no standard convention among instrument manufacturers for the confidence limits at which specifications are set. The table below shows the probability of non-conformance for *each specification* with the given assumptions.

Specification Criteria	Probability of Failure
Mean ± 2 sigma	4.5%
Mean ± 3 sigma	0.3%

Variations in performance from reading to reading, and instrument to instrument, decrease for increasing number of sigma for a given specification. This means that you can achieve greater actual measurement precision for a specific accuracy specification number. The 34970A/34972A is designed and tested to meet performance better than mean ± 3 sigma of the published accuracy specifications.

Interpreting Internal DMM Specifications

24-Hour Accuracy

The 24-hour accuracy specification indicates the internal DMM's relative accuracy over its full measurement range for short time intervals and within a stable environment. Short-term accuracy is usually specified for a 24-hour period and for a ± 1 °C temperature range.

90-Day and 1-Year Accuracy

These long-term accuracy specifications are valid for a 23 °C ± 5 °C temperature range. These specifications include the initial calibration errors plus the internal DMM's long-term drift errors.

Temperature Coefficients

Accuracy is usually specified for a 23 °C ± 5 °C temperature range. This is a common temperature range for many operating environments. You must add additional temperature coefficient errors to the accuracy specification if you are operating the internal DMM outside a 23 °C ± 5 °C temperature range (the specification is per °C).

Configuring for Highest Accuracy Measurements

The measurement configurations shown below assume that the internal DMM is in its *Factory Reset* state. It is also assumed that manual ranging is enabled to ensure proper full scale range selection.

DC Voltage, DC Current, and Resistance Measurements:

- Set the resolution to 6 digits (you can use the 6 digits slow mode for further noise reduction).
- Set the input resistance to greater than 10 G Ω (for the 100 mV, 1 V, and 10 V ranges) for the best DC voltage accuracy.
- Use 4-wire ohms and enable offset compensation for the best resistance accuracy.

AC Voltage and AC Current Measurements:

- Set the resolution to 6 digits.
- Select the slow AC filter (3 Hz to 300 kHz).



Frequency and Period Measurements:

- Set the resolution to 6 digits.

Quick Start

Quick Start

One of the first things to do with your instrument is to become acquainted with the front panel. We have written the exercises in this chapter to prepare the instrument for use and help you get familiar with some of its front-panel operations.

The front panel has several groups of keys to select various functions and operations. A few keys have a *shifted* function printed in blue below the key. To perform a shifted function, press  (the **SHIFT** annunciator will turn on). Then, press the key that has the desired label below it. For example, to select the Utility Menu, press  .

If you accidentally press , just press it again to turn off the **SHIFT** annunciator.

This chapter is divided into the following sections:

- To Prepare the Instrument for Use, *on page 43*
- To Connect Wiring to a Module, *on page 44*
- To Set the Time and Date, *on page 46*
- To Configure a Measurement Channel, *on page 47*
- To Monitor a Single Channel, *on page 48*
- To Close a Channel, *on page 49*
- If the Instrument Does Not Turn On, *on page 50*
- To Adjust the Carrying Handle, *on page 52*
- To Rack Mount the Instrument, *on page 53*

To Prepare the Instrument for Use

1 Check the list of supplied items.

Verify that you have received the following items with your instrument. If anything is missing, contact your nearest Agilent Technologies Sales Office.

- One power cord.
- One *User's Guide*.
- This *Service Guide*.
- One *Quick Reference Guide*.
- Certificate of Calibration (if you ordered the internal DMM).
- BenchLink Data Logger 3 Software CD-ROM.
- Quick Start Package (if you ordered the internal DMM):
 - One RS-232 cable.
 - One J-type thermocouple and a flatblade screwdriver.
- Any plug-in modules that you ordered are delivered in a separate shipping container.



On/Standby
Switch

WARNING

*Note that this switch is **Standby** only. To disconnect the mains from the instrument, remove the power cord.*

2 Verify that the fuse on the back is set to the proper voltage range for your AC power.

3 Connect the power cord and turn on the instrument.

The front-panel display will light up briefly while the instrument performs its power-on self-test. The instrument initially powers up with all measurement channels turned off. To review the power-on display with all annunciators turned on, hold down **Shift** as you turn on the instrument. *If the instrument does not turn on properly, see page 50.*

4 Perform a complete self-test.

The *complete* self-test performs a more extensive set of tests than those performed at power-on. Hold down **Shift** as you turn on the instrument and *hold down the key until you hear a long beep*. The self-test will begin when you release the key following the beep.

To Connect Wiring to a Module

1. Remove the module cover.

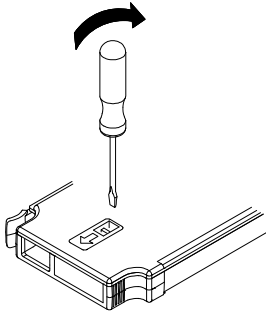

2. Connect wiring to the screw terminals.

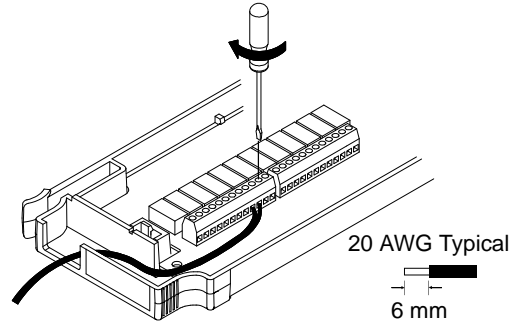

3. Route wiring through strain relief.

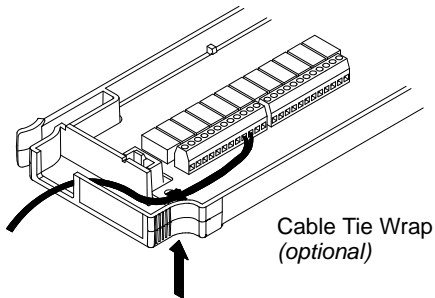

4. Replace the module cover.

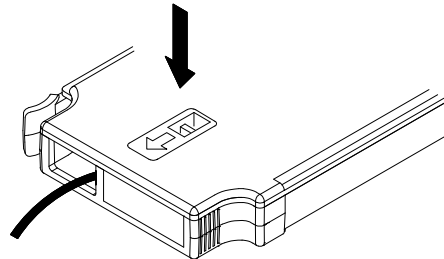

5. Install the module into mainframe.

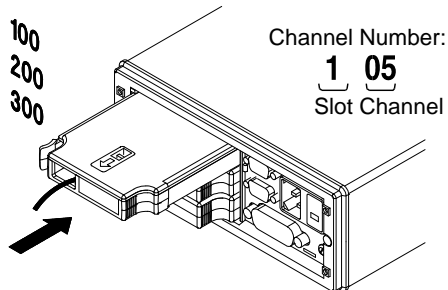

Wiring Hints...

- For detailed information on each module, refer to the 34970A/34972A User's Guide.
- To reduce wear on the internal DMM relays, wire like functions on adjacent channels.
- Use shielded twisted pair Teflon® insulated cables to reduce settling and noise errors.
- The diagrams on the next page show how to connect wiring to a multiplexer module for each measurement function. →

Thermocouple

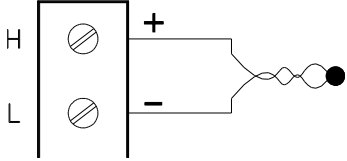

Thermocouple Types: B, E, J, K, N, R, S, T
See the 34970A/34972A User's Guide for thermocouple color codes.

DC Voltage / AC Voltage / Frequency

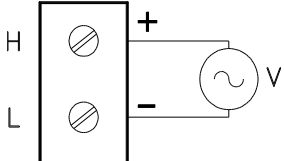

Ranges: 100 mV, 1 V, 10 V, 100 V, 300 V

2-Wire Ohms / RTD / Thermistor

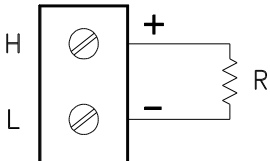

Ranges: 100, 1 k, 10 k, 100 k, 1 M, 10 M, 100 MΩ
RTD Types: 0.00385, 0.00391
Thermistor Types, 2.2 k, 5 k, 10 k

4-Wire Ohms / RTD

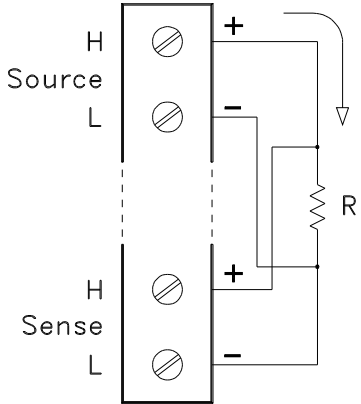

Channel *n* (source) is automatically paired with Channel *n* + 10 (sense) on the 34901A, or Channel *n* + 8 (sense) on the 34902A.

Ranges: 100, 1 k, 10 k, 100 k, 1 M, 10 M, 100 MΩ
RTD Types: 0.00385, 0.00391

DC Current / AC Current

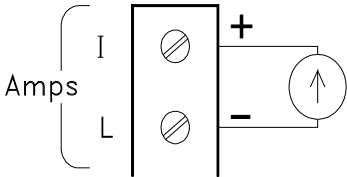



Valid only on channels 21 and 22 on the 34901A
Ranges: 10 mA, 100 mA, 1A

To Set the Time and Date

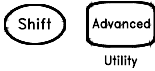
All readings during a scan are automatically time stamped and stored in non-volatile memory. In addition, alarm data is time stamped and stored in a separate non-volatile memory queue.





1 Set the time of day.

Use  and  to select the field to modify and turn the knob to change the value. You can also edit the AM/PM field.

TIME 03:45 PM



2 Set the date.

Use  and  to select the field to modify and turn the knob to change the value.

JUN 01 2002



To Configure a Measurement Channel

Use this general procedure to configure a measurement channel.



1 Select the channel.

Turn the knob until the desired channel is shown on the right side of front-panel display. The channel number is a three-digit number; the left-most digit represents the slot number (100, 200, or 300) and the two digits on the right indicate the channel number (102, 110, etc.).

Note: You can use  and  to skip to the beginning of the previous or next slot.



2 Select the measurement parameters for the selected channel.

Use the knob to scroll through the measurement choices on each level of the menu. When you press  to make your selection, the menu automatically guides you through all relevant choices to configure a measurement on the selected function. When you have finished configuring the parameters, you are automatically exited from the menu.

The present selection (or default) is displayed in full bright for easy identification. When you make a different selection, the new choice is shown in full bright and it becomes the default selection. The order of the choices always remains the same; however, you always enter the menu at the current (full bright) setting for each parameter.

Note: The menu will time-out after about 20 seconds of inactivity and any changes made previously will take effect.

To Monitor a Single Channel

You can use the *Monitor* function to continuously take readings on a single channel, even during a scan. This feature is used during front panel calibration procedures.



1 Select the channel to be monitored.

Only one channel can be monitored at a time but you can change the channel being monitored at any time by turning the knob.



2 Enable monitoring on the selected channel.

Any channel that can be “read” by the instrument can be monitored (the **MON** annunciator turns on). This includes any combination of temperature, voltage, resistance, current, frequency, or period measurements on multiplexer channels. You can also monitor a digital input port or the totalizer count on the multifunction module.

To disable monitoring, press  again.

To Close a Channel

On the multiplexer and switch modules, you can close and open individual relays on the module. However, note that if you have already configured any multiplexer channels for scanning, you cannot independently close and open individual relays on that module.



1 Select the channel.

Turn the knob until the desired channel is shown on the right side of front-panel display. For this example, select channel 213.



2 Close the selected channel.



3 Open the selected channel.

Note: will sequentially open all channels on the module in the selected slot.

The table below shows the low-level control operations available for each of the plug-in modules.

Plug-In Module					,
34901A 20-Channel Mux	•	•	•		•
34902A 16-Channel Mux	•	•	•		•
34908A 40-Channel Single-Ended Mux ^[1]	•	•	•		•
34903A 20-Channel Actuator	•	•			
34904A 4x8 Matrix	•	•			
34905A Dual 4-Channel RF Mux (50Ω) ^[2]	•				
34906A Dual 4-Channel RF Mux (75Ω) ^[2]	•				
34907A Multifunction Module (DIO)			•	•	•
34907A Multifunction Module (Totalizer)			•		•
34907A multifunction Module (DAC)				•	

[1] Only one channel can be closed at a time on this module.

[2] Only one channel in each bank can be closed at a time on this module.

If the Instrument Does Not Turn On

Use the following steps to help solve problems you might encounter when turning on the instrument.

1 Verify that there is AC power to the instrument.

First, verify that the power cord is firmly plugged into the power receptacle on the rear panel of the instrument. You should also make sure that the power source you plugged the instrument into is energized. Then, verify that the instrument is turned on.

The On/Standby switch  is located on the lower left side of the front panel.

2 Verify the power-line voltage setting.

The line voltage is set to the proper value for your country when the instrument is shipped from the factory. Change the voltage setting if it is not correct. The settings are: 100, 120, 220, or 240 VAC.

***Note:** For 127 VAC operation, use the 120 VAC setting.
For 230 VAC operation, use the 220 VAC setting.*

See the next page if you need to change the line voltage setting.

3 Verify that the power-line fuse is good.

The instrument is shipped from the factory with a 500 mA fuse installed. This is the correct fuse for all line voltages.

See the next page if you need to replace the power-line fuse.

To replace the 500 mA, 250 V fuse, order Agilent part number 2110-0458.

1 Remove the power cord. Remove the fuse-holder assembly from the rear panel.

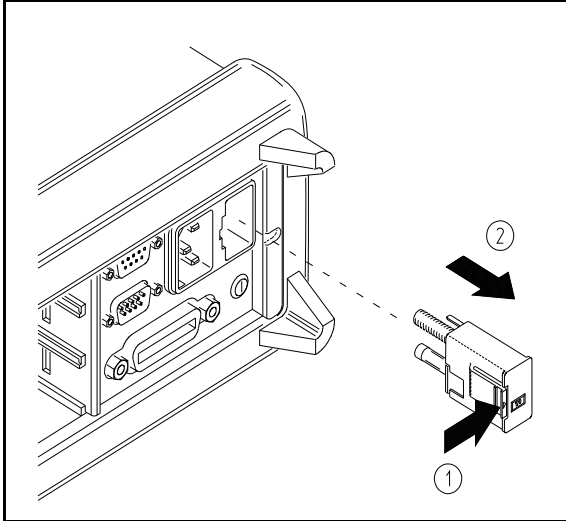

2 Remove the line voltage selector from the assembly.

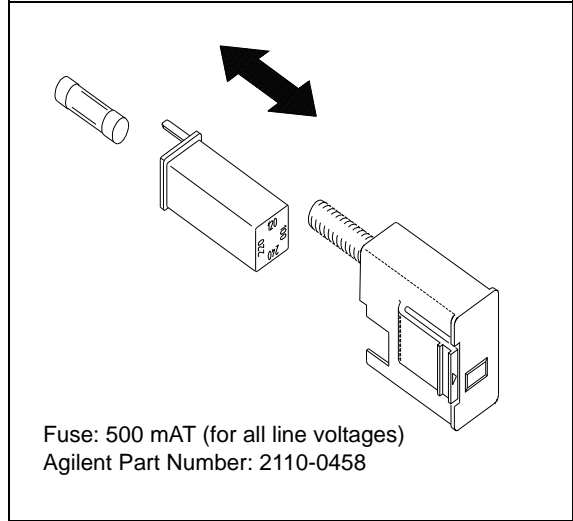

Fuse: 500 mA (for all line voltages)
Agilent Part Number: 2110-0458

3 Rotate the line-voltage selector until the correct voltage appears in the window.

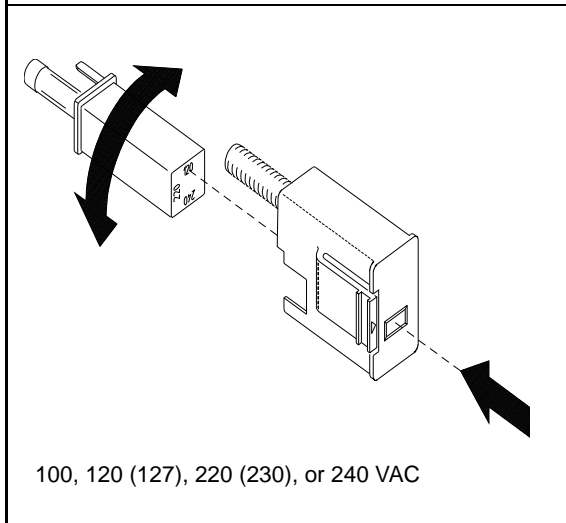

4 Replace the fuse-holder assembly in the rear panel.

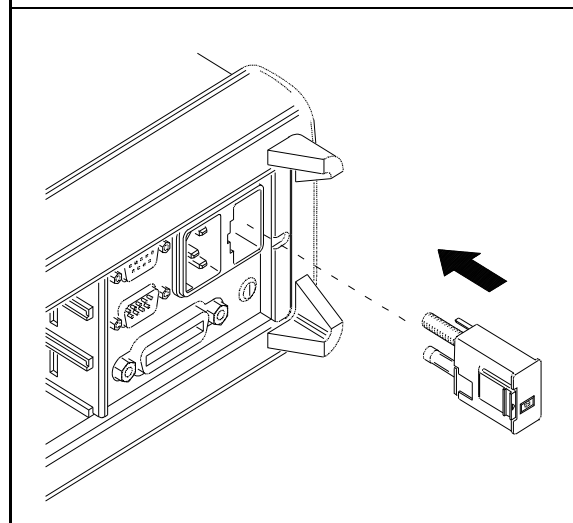

Verify that the correct line voltage is selected and the power-line fuse is good.

To Adjust the Carrying Handle

To adjust the position, grasp the handle by the sides and *pull outward*. Then, rotate the handle to the desired position.

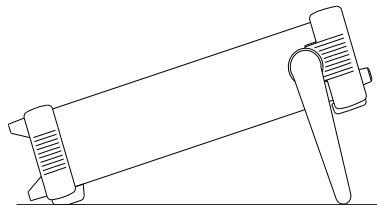
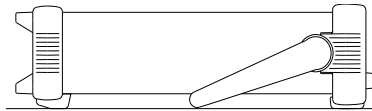

Bench-top viewing position

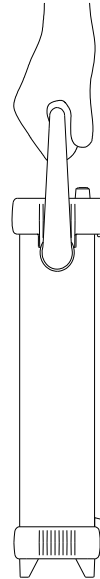

Carrying position

To Rack Mount the Instrument

You can mount the instrument in a standard 19-inch rack cabinet using one of three optional kits available. Instructions and mounting hardware are included with each rack-mounting kit. Any Agilent *System II* instrument of the same size can be rack-mounted beside the 34970A/34972A.

Note: Remove the carrying handle, and the front and rear rubber bumpers, before rack-mounting the instrument.

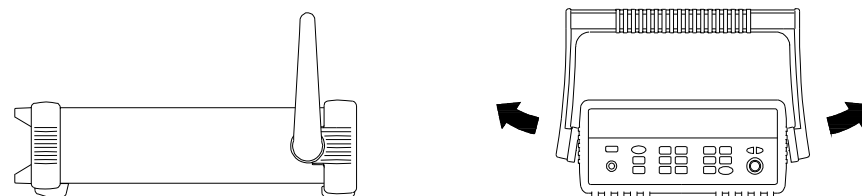

To remove the handle, rotate it to the vertical position and pull the ends outward.

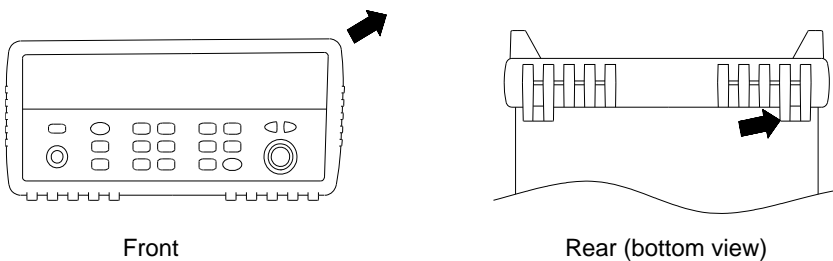

To remove the rubber bumper, stretch a corner and then slide it off.

Chapter 2 Quick Start
To Rack Mount the Instrument

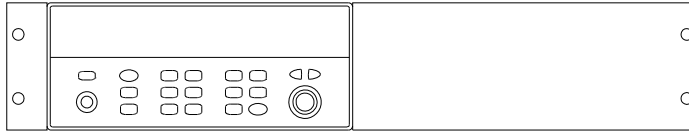

To rack mount a single instrument, order adapter kit 5063-9240.

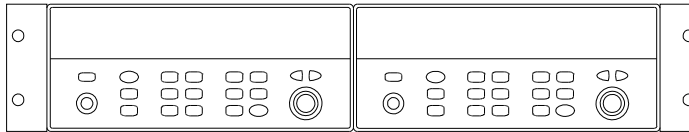

To rack mount two instruments side-by-side, order lock-link kit 5061-9694 and flange kit 5063-9212. Be sure to use the support rails inside the rack cabinet.

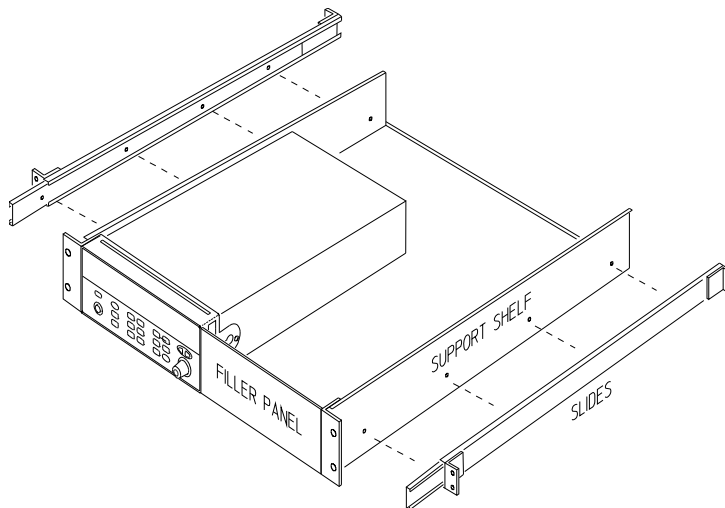

To install one or two instruments in a sliding support shelf, order shelf 5063-9255, and slide kit 1494-0015 (for a single instrument, also order filler panel 5002-3999).

Front-Panel Overview

Front-Panel Overview

This chapter introduces you to the front-panel keys and menu operation. This chapter does not give a detailed description of every front-panel key or menu operation. It does, however, give you an overview of the front-panel menus and many front-panel operations. See the *Agilent 34970A/34972A User's Guide* for a complete discussion of the instrument's capabilities and operation.

This chapter is divided into the following sections:

- Front-Panel Menu Reference, *on page 57*
- To Unsecure for Calibration, *on page 60*
- To Secure Against Calibration, *on page 61*
- To Change the Security Code, *on page 62*
- Error Messages, *on page 62*
- To Perform a Zero Adjustment, *on page 63*
- To Apply Mx+B Scaling to Measurements, *on page 64*
- To Read the Relay Cycle Count, *on page 65*
- To Read a Digital Input Port, *on page 66*
- To Write to a Digital Output Port, *on page 67*
- To Read the Totalizer Count, *on page 68*
- To Output a DC Voltage, *on page 69*

Front-Panel Menu Reference

This section gives an overview of the front-panel menus. The menus are designed to automatically guide you through all parameters required to configure a particular function or operation. The remainder of this chapter contains examples of using the front-panel menus.



Configure the measurement parameters on the displayed channel.

- Select the measurement function (dc volts, ohms, etc.) on the displayed channel.
- Select transducer type for temperature measurements.
- Select units (°C, °F, or K) for temperature measurements.
- Select measurement range or autorange.
- Select measurement resolution.
- Copy and paste measurement configuration to other channels.



Configure the scaling parameters for the displayed channel.

- Set the gain (“M”) and offset (“B”) value for the displayed channel.
- Make a null measurement and store it as the offset value.
- Specify a custom label (RPM, PSI, etc.) for the displayed channel.



Configure alarms on the displayed channel.

- Select one of four alarms to report alarm conditions on the displayed channel.
- Configure a high limit, low limit, or both for the displayed channel.
- Configure a bit pattern that will generate an alarm (digital input only).



Configure the four Alarm Output hardware lines.

- Clear the state of the four alarm output lines.
- Select the “Latch” or “Track” mode for the four alarm output lines.
- Select the slope (rising or falling edge) for the four alarm output lines.



Configure the event or action that controls the scan interval.

- Select the scan interval mode (interval, manual, external, or alarm).
- Select the scan count.

Advanced

Configure the advanced measurement features on displayed channel.

- Set the integration time for measurements on the displayed channel.
- Set the channel-to-channel delay for scanning.
- Enable/disable the thermocouple check feature (T/C measurements only).
- Select the reference junction source (T/C measurements only).
- Set the low frequency limit (ac measurements only).
- Enable/disable offset compensation (resistance measurements only).
- Select the binary or decimal mode for digital operations (34907A only).
- Configure the totalizer reset mode (totalizer only).
- Select which edge is detected (rising or falling) for totalizer operations.

Utility

Configure system-related instrument parameters.

- Set the real-time system clock and calendar.
- Query the firmware revisions for the mainframe and installed modules.
- Select the instrument's power-on configuration (last or factory reset).
- Enable/disable the internal DMM.
- Secure/unsecure the instrument for calibration.

View

View readings, alarms, and errors.

- View the last 100 scanned readings from memory (last, min, max, and average).
- View the first 20 alarms in the alarm queue (reading and time alarm occurred).
- View up to 10 errors (34970A) or 20 errors (34972A) in the error queue.
- Read the number of cycles for the displayed relay (relay maintenance feature).

Sto/Rcl

Store and recall instrument states.

- Store up to five instrument states in non-volatile memory.
- Assign a name to each storage location.
- Recall stored states, power-down state, factory reset state, or preset state.



Configure the remote interface (34970A).

- Select the GPIB address.
- Configure the RS-232 interface (baud rate, parity, and flow control).





Configure the remote interface (34972A).

- Configure the LAN settings (IP Address, Hostname, DHCP, etc.)
- Configure the USB settings (Enable, USB ID, etc.)
- Configure and use the USB drive (Logging, etc.)

To Unsecure for Calibration

You can unsecure the instrument either from the front panel or over the remote interface. The instrument is secured when shipped from the factory and the security code is set to “HP034970” or “AT034972”, depending on the product number.

- Once you enter a security code, that code must be used for both front-panel and remote operation. For example if you secure the instrument from the front panel, you must use that same code to unsecure it from the remote interface.
- Press  to enter the *Utility* menu.



When you first enter the *Utility* menu, the calibration entries toggle between CAL SECURED and UNSECURE CAL. To unsecure the instrument, select UNSECURE CAL and press . After entering the correct security code, press  again. When you return to the menu, you will see new choices CAL UNSECURED and SECURE CAL.

Note: If you enter the wrong secure code, NO MATCH is displayed and a new choice, EXIT, is shown.

To Secure Against Calibration

You can secure the instrument either from the front panel or over the remote interface. The instrument is secured when shipped from the factory and the security code is set to “HP034970” or “AT034972”, depending on the product number.

- Once you enter a security code, that code must be used for both front-panel and remote operation. For example if you secure the instrument from the front panel, you must use that same code to unsecure it from the remote interface.
- Press  to enter the *Utility* menu.

When you enter the *Utility* menu, the calibration entries toggle between CAL UNSECURED and SECURE CAL. To secure the instrument, select SECURE CAL and press . After entering the desired security code, press  again. When you return to the menu, you will see new choices CAL SECURED and UNSECURE CAL.

To Change the Security Code

- To change the security code, you must first unsecure the instrument, and then enter a new code. Make sure you have read the security code rules described on page 77 before attempting to change the security code.
- To change the security code, first make sure that the instrument is unsecured. Go to the **SECURE CAL** entry, enter the new security code, and press **UTILITY** (the instrument is now secured with the new code). Changing the code from the front panel also changes the code as seen from the remote interface.

Error Messages

Error messages are retrieved in a first-in-first-out (FIFO) order.

When the **ERROR** annunciator is on, press **UTILITY** to view error messages. use the arrow keys to scroll the message in the display.

A list of the self-test errors messages and their meanings begins on page 178.

For a complete list of error messages and descriptions, see chapter 6 in the *34970A/34972A User's Guide*.

To Perform a Zero Adjustment

The instrument features closed case electronic calibration. No internal mechanical adjustments are required. The instrument calculates correction factors based upon an input reference value and stores the correction factors in non-volatile memory. This procedure demonstrates making the zero adjustment from the front panel. The gain adjustments are similar.

DO NOT perform this procedure before reading Chapter 4. Chapter 4 describes this procedure, the required input connections, input signals, and test considerations required for a valid adjustment.

Measure

1 Configure the channel.

You must configure a channel before applying performing the adjustment procedure. Configure the channel to DC VOLTS and 6½ digits.

2 Apply the input signal

In this example, the input signal is a copper short (*see page 76*).

Shift

View

3 Setup the calibration.

The display will show PERFORM CAL.

View

4 Set the adjustment value.

The display will show the a number. Edit the number to the actual input value. For the Zero Adjustment, the input value is 0.000000.

+000.000,000 mVDC

View

5 Begin the adjustment.

The display will show the progress of the adjustment. When all the adjustments are completed, the display will show done.

DONE

To Apply Mx+B Scaling to Measurements

The scaling function allows you to apply a *gain* and *offset* to all readings on a specified multiplexer channel during a scan. In addition to setting the gain (“M”) and offset (“B”) values, you can also specify a custom measurement label for your scaled readings (RPM, PSI, etc.).

Measure

1 Configure the channel.

You must configure the channel (function, transducer type, etc.) before applying any scaling values. If you change the measurement configuration, scaling is turned off on that channel and the gain and offset values are reset (M=1 and B=0).

Mx+B

2 Set the gain and offset values.

The scaling values are stored in *non-volatile* memory for the specified channels. A Factory Reset turns off scaling and clears the scaling values on all channels. An Instrument Preset or Card Reset *does not* clear the scaling values and *does not* turn off scaling.

+1.000,000

Set Gain

-0.700,000 OHM

Set Offset

Mx+B

3 Select the custom label.

You can specify an optional three-character label for your scaled readings (RPM, PSI, etc.). The default label is the standard engineering unit for the selected function (VDC, OHM, etc.).

LABEL AS OHM

Scan

4 Scaling is now applied to the measurements.

To Read the Relay Cycle Count

The instrument has a *Relay Maintenance System* to help you predict relay end-of-life. The instrument counts the cycles on each relay in the instrument and stores the total count in non-volatile memory on each switch module. You can use this feature on any of the relay modules and the internal DMM.

- In addition to the channel relays, you can also query the count on backplane relays and bank relays. Note that you cannot control the state of these relays from the front panel but you can query the count.
- You can also query the state of the three relays on the internal DMM. These relays are numbered “1”, “2”, and “3” (which correspond to relays K102, K103, and K104 respectively). These relays open or close when a function or range is changed on a module.
- The 34908A multiplexer contains 40 channels which are switched (HI only) using only 20 relays. Each relay is used to switch HI on two different channels (and only one channel can be closed at a time). The channels are arranged such that channels 01 and 21 use different contacts on the same relay. The remaining channels are also paired in the same manner (channels 02 and 22, channels 03 and 23, etc.). Therefore, when you query the relay count on a channel, the number reflects the number of times that the relay was closed. For example, the relay count will always be the same on channels 01 and 21.
- For more information on relay life and load considerations, refer to “Relay Life and Preventative Maintenance” in the *34970A/34972A User’s Guide*.
- To read the count on the active channel, choose the following item and then turn the knob. To read the count on the internal DMM relays, turn the knob counterclockwise beyond the lowest numbered channel in the instrument. To read the “hidden” relays, turn the knob clockwise beyond the highest numbered channel in the current slot.

 RELAY CYCLES

To Read a Digital Input Port

The multifunction module (34907A) has two non-isolated 8-bit input/output ports which you can use for reading digital patterns. You can read the live status of the bits on the port or you can configure a scan to include a digital read.



1 Select the Digital Input port.

Select the slot containing the multifunction module and continue turning the knob until DIN is displayed (channel 01 or 02).



2 Read the specified port.

You can specify whether you want to use binary or decimal format. Once you have selected the number base, it is used for all input or output operations on the same port. To change the number base, press the and select USE BINARY or USE DECIMAL.

`01010101 DIN`

Binary Display Shown

The bit pattern read from the port will be displayed until you press another key, turn the knob, or until the display times out.

Note: To add a digital input channel to a scan list, press and select the DIO READ choice.

To Write to a Digital Output Port

The multifunction module (34907A) has two non-isolated 8-bit input/output ports which you can use for outputting digital patterns.



1 Select the Digital Output port.

Select the slot containing the multifunction module and continue turning the knob until DIN is displayed (channel 01 or 02).





2 Enter the bit pattern editor.

Notice that the port is now converted to an output port (DOUT).

00000000 DOUT

Binary Display Shown

3 Edit the bit pattern.

Use the knob and  or  keys to edit the individual bit values. You can specify whether you want to use binary or decimal format. Once you have selected the number base, it is used for all input or output operations on the same port. To change the number base, press the  key and select USE BINARY or USE DECIMAL.

240 DOUT

Decimal Display Shown



4 Output the bit pattern to the specified port.

The specified bit pattern is latched on the specified port. To cancel an output operation in progress, wait for the display to time out.

To Read the Totalizer Count

The multifunction module (34907A) has a 26-bit totalizer which can count pulses at a 100 kHz rate. You can manually read the totalizer count or you can configure a scan to read the count.



1 Select the totalizer channel.

Select the slot containing the multifunction module and continue turning the knob until TOTALIZE is displayed (channel 03).



2 Configure the totalize mode.

The internal count starts as soon as you turn on the instrument. You can configure the totalizer to reset the count to “0” after being read or it can count continuously and be manually reset.

READ + RESET



3 Read the count.

The count is read once each time you press ; the count does not update automatically on the display. As configured in this example, the count is automatically reset to “0” each time you read it.

12345 TOT

The count will be displayed until you press another key, turn the knob, or until the display times out. To manually reset the totalizer count, press .

Note: To add a totalizer channel to a scan list, press and select the TOT READ choice.

To Output a DC Voltage

The multifunction module (34907A) has two analog outputs capable of outputting calibrated voltages between ± 12 volts.



1 Select a DAC Output channel.

Select the slot containing the multifunction module and continue turning the knob until DAC is displayed (channel 04 or 05).



2 Enter the output voltage editor.

+00.000 V DAC

3 Set the desired output voltage.

Use the knob and ◀ or ▶ keys to edit the individual digits.

+05.250VDAC



4 Output the voltage from the selected DAC.

The output voltage will be displayed until you press another key or turn the knob. To manually reset the output voltage to 0 volts, press . . A rectangular button with rounded corners and the words "Card Reset" inside.

Chapter 3 Front-Panel Overview
To Output a DC Voltage

Calibration Procedures

Calibration Procedures

This chapter contains procedures for verification of the instrument's performance and adjustment (calibration). *These procedures are required only if the internal DMM is installed.* The chapter is divided into the following sections:

- Agilent Technologies Calibration Services, *on page 73*
- Calibration Interval, *on page 73*
- Time Required for Calibration, *on page 74*
- Automating Calibration Procedures, *on page 74*
- Recommended Test Equipment, *on page 75*
- Input Connections, *on page 76*
- Calibration Security, *on page 77*
- Calibration Message, *on page 79*
- Calibration Count, *on page 79*
- Calibration Procedure, *on page 80*
- Aborting a Calibration in Progress, *on page 80*
- Test Considerations, *on page 81*
- Performance Verification Tests, *on page 82*
- Internal DMM Verification Tests, *on page 85*
- Optional AC Performance Verification Tests, *on page 90*
- Internal DMM Adjustments, *on page 91*
- -10 VDC Adjustment Procedure (Optional), *on page 95*
- Plug-in Module Test Considerations, *on page 97*
- Relay Verification, *on page 98*
- Thermocouple Reference Junction (Optional), *on page 122*
- 34907A Analog Output, *on page 124*

Closed-Case Electronic Calibration The instrument features closed-case electronic calibration. No internal mechanical adjustments are required. The instrument calculates correction factors based upon the input reference value you set. The new correction factors are stored in non-volatile memory until the next calibration adjustment is performed. Non-volatile EEPROM calibration memory does not change when power has been off or after a remote interface reset.

Agilent Technologies Calibration Services

When your instrument is due for calibration, contact your local Agilent Service Center for a low-cost recalibration. The 34970A/34972A is supported on automated calibration systems which allow Agilent to provide this service at competitive prices.

Calibration Interval

The instrument should be calibrated on a regular interval determined by the measurement accuracy requirements of your application.

A 1-year interval is adequate for most applications. Accuracy specifications are warranted *only* if adjustment is made at regular calibration intervals. Accuracy specifications are not warranted beyond the 1-year calibration interval. Agilent does not recommend extending calibration intervals beyond 2 years for any application.

Adjustment is Recommended

Whatever calibration interval you select, Agilent recommends that *complete re-adjustment should always be performed* at the calibration interval. This will assure that the 34970A/34972A will remain within specification for the next calibration interval. This criteria for re-adjustment provides the best long-term stability. Performance data measured using this method *can* be used to extend future calibration intervals.

Use the Calibration Count feature (*see page 79*) to verify that all adjustments have been performed.

Time Required for Calibration

The 34970A/34972A can be automatically calibrated under computer control. With computer control you can perform the complete calibration procedure and performance verification tests in less than 30 minutes once the instrument is warmed-up (see *“Test Considerations”* on page 81). Manual calibrations using the recommended test equipment will take approximately 2 hours.

Automating Calibration Procedures

You can automate the complete verification and adjustment procedures outlined in this chapter if you have access to programmable test equipment. You can program the instrument configurations specified for each test over the remote interface. You can then enter readback verification data into a test program and compare the results to the appropriate test limit values.

You can also adjust the instrument from the remote interface. Remote adjustment is similar to the local front-panel procedure. You can use a computer to perform the adjustment by first selecting the required function and range. The calibration value is sent to the instrument and then the calibration is initiated over the remote interface. The instrument must be unsecured prior to initiating the calibration procedure.

For further information on programming the instrument, see chapter 5 in the *34970A/34972A User’s Guide*.

Recommended Test Equipment

The test equipment recommended for the performance verification and adjustment procedures is listed below. If the exact instrument is not available, substitute calibration standards of equivalent accuracy.

A suggested alternate method would be to use the Agilent 3458A 8½-digit Digital Multimeter to measure less accurate yet stable sources. The output value measured from the source can be entered into the instrument as the target calibration value.

Application	Recommended Equipment	Accuracy Requirements
Zero Calibration ^[1]	None	4 -terminal all copper short
DC Voltage ^[1]	Fluke 5700A	<1/5 instrument 24 hour spec
Dc Current ^[1]	Fluke 5700A/5725A	<1/5 instrument 24 hour spec
Resistance ^[1]	Fluke 5700A	<1/5 instrument 24 hour spec
AC Voltage ^[1]	Fluke 5700A/5725A	<1/5 instrument 24 hour spec
AC Current ^[1]	Fluke 5700A/5725A	<1/5 instrument 24 hour spec
Frequency ^[1]	Agilent 33220A	<1/5 instrument 24 hour spec
Analog Output 34907A	Agilent 34401A	<1/5 instrument 24 hour spec
Thermocouple Reference Junction 34901A 34902A 34908A	Thermistor YSI 44031 (two) ^[2] J Type Calibrated Thermocouple Triple Point Cell	±0.1 °C
Relay contact resistance All switch modules	Agilent 34401A	±0.001Ω resolution

[1] In addition to the internal DMM, these applications require an input multiplexer module. The Agilent 34901A is recommended.

[2] Thermistor YSI 44031 is available as Agilent part number 34308A (package of five).

Input Connections

You will need an input multiplexer module to verify or adjust the internal DMM. Input connections can be made using a 34901A 20-Channel Multiplexer.

To use a 34901A to completely verify and adjust the internal DMM, make the following connections:

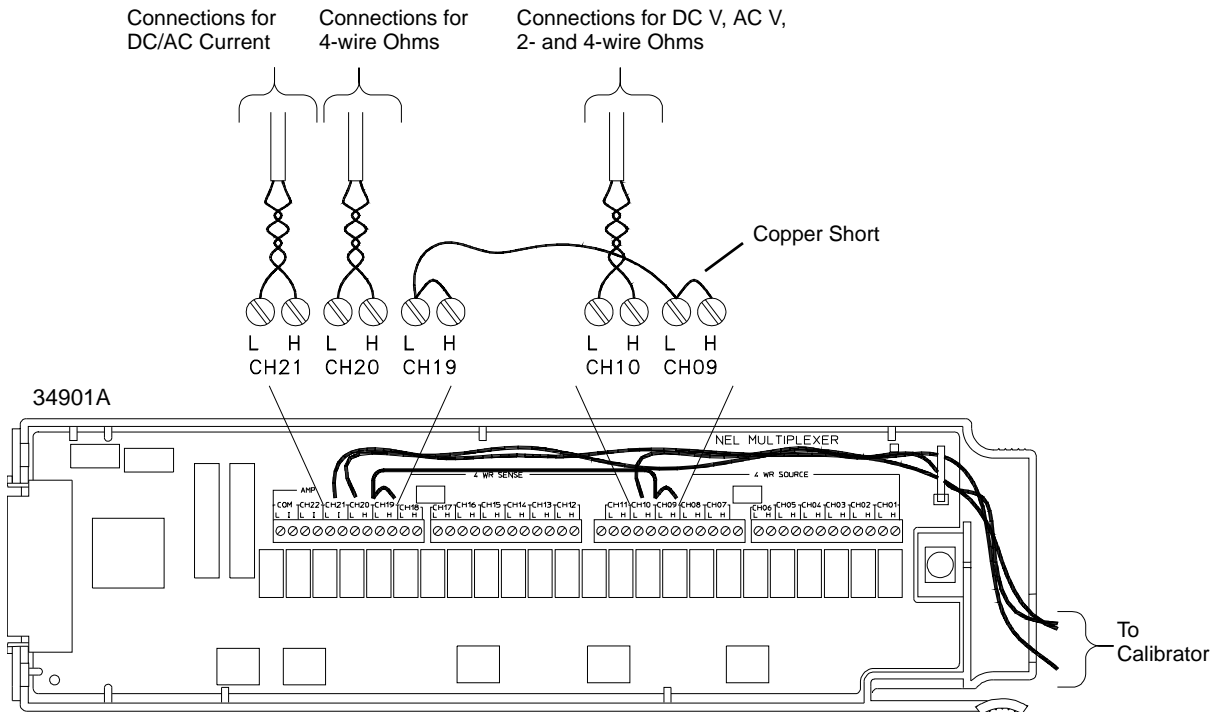

Note: Use shielded twisted pair Teflon[®] insulated cables to reduce settling and noise errors. Connect the shield to the source LO output.

You can also use a 34902A for test and adjustment of voltage, frequency, and resistance functions. You cannot test or adjust current inputs with a 34902A. If you use a 34902A, connect the copper shorts to Channels 7 and 15 and make the input connections to Channels 8 and 16.

Teflon[®] is a registered trademark of E.I. du Pont de Nemours and Company.

Calibration Security

This feature allows you to enter a security code to prevent accidental or unauthorized adjustments of the instrument. When you first receive your instrument, it is secured. Before you can adjust the instrument, you must unsecure it by entering the correct security code. *See page 60 in Chapter 3 for a procedure to enter the security code.*

- The security code is set to “HP034970” or “AT034972”, depending on the product number, when the instrument is shipped from the factory. The security code is stored in *non-volatile* memory, and *does not* change when power has been off, after a Factory Reset (*RST command), or after an Instrument Preset (SYSTEM:PRESet command).
- The security code may contain up to 12 alphanumeric characters. The first character *must* be a letter, but the remaining characters can be letters, numbers, or an underscore (_). You do not have to use all 12 characters but the first character must always be a letter.

Note: *If you forget your security code, you can disable the security feature by adding a jumper inside the instrument as described on the following page.*

To Unsecure the Instrument Without the Security Code

To unsecure the instrument without the correct security code, follow the steps below. A front panel procedure to unsecure the instrument is given on page 60. See “*Electrostatic Discharge (ESD) Precautions*” on page 172 before beginning this procedure.

WARNING

SHOCK HAZARD. Only service-trained personnel who are aware of the hazards involved should remove the instrument covers. The procedures in this section require that you connect the power cord to the instrument with the covers removed. To avoid electrical shock and personal injury, be careful not to touch the power-line connections.

- 1 Disconnect the power cord and all input connections.
- 2 Remove the instrument cover (see page 183). Turn the instrument over.
- 3 Apply power and turn on the instrument.
Be careful not to touch the power line connections.
- 4 Apply a short between the two exposed metal pads marked CAL UNLOCK as shown in the figure below.

WARNING

- Exposed Mains
- Do not Touch!

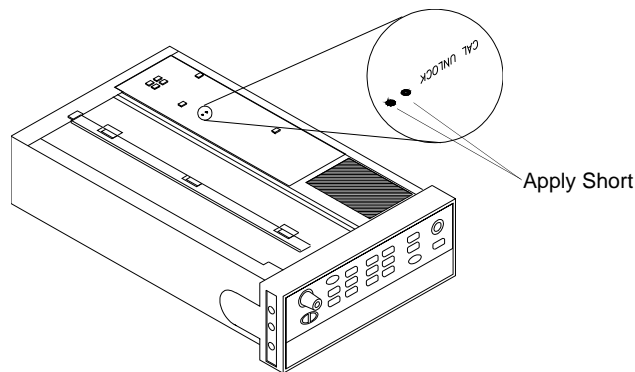



- 5 While maintaining the short, enter any unsecure code. The instrument is now unsecured.
- 6 Remove the short.
- 7 Turn off the instrument and remove the power cord. Reassemble the instrument.

Now you can enter a new security code. Be sure to remember the new security code.

Calibration Message

The instrument allows you to store one message in calibration memory. For example, you can store such information as the date when the last calibration was performed, the date when the next calibration is due, the instrument's serial number, or even the name and phone number of the person to contact for a new calibration.

- You can record a calibration message *only* from the remote interface and *only* when the instrument is unsecured. You can read the message from either the front-panel or over the remote interface. You can read the calibration message whether the instrument is secured or unsecured.
- The calibration message may contain up to 40 characters. From the front panel, you can view 13 characters of the message at a time. Press  to scroll through the text of the message. Press  again to increase the scrolling speed.

Calibration Count

You can query the instrument to determine how many calibrations have been performed. Note that your instrument was calibrated before it left the factory. When you receive your instrument, be sure to read the count to determine its initial value.

- The calibration count increments up to a maximum of 65,535 after which it rolls over to “0”. Since the value increments by one for each calibration point, a complete calibration may increase the value by many counts.
- The calibration count is also incremented with calibrations of the DAC channels on the multifunction module.
- *Front-Panel Operation:*

  CAL COUNT

- *Remote Interface Operation:*

CALibration:COUNT?

Calibration Procedure

The following procedure is the recommended method to complete an instrument calibration.

- 1 Read “Test Considerations” (*page 81*).
- 2 Unsecure the instrument for calibration (*page 60*).
- 3 Perform the *verification* tests to characterize the instrument (incoming data).
- 4 Perform the zero *adjustment* procedures.
- 5 Perform the gain *adjustment* procedures. Perform the *verification* tests to verify the adjustments (outgoing data).
- 6 Secure the instrument against calibration.
- 7 Note the new security code and calibration count in the instrument’s maintenance records.

Aborting a Calibration in Progress

Sometimes it may be necessary to abort a calibration after the procedure has already been initiated. You can abort a calibration at any time by turning off the power. When performing a calibration from the remote interface, you can abort a calibration by issuing a remote interface device clear message.

CAUTION

*If you abort a calibration in progress when the instrument is attempting to write new calibration constants to EEPROM, you may lose all calibration constants for the function. Typically, upon re-applying power, the instrument will report error **705 Cal:Aborted**. You may also generate errors 740 through 746. If this occurs, you should not use the instrument until a complete re-adjustment has been performed.*

Test Considerations

To ensure proper instrument operation, verify that you have selected the correct power line voltage prior to attempting any procedure in this chapter. See *“If the Instrument Does Not Turn On”*, on page 50.

Errors may be induced by AC signals present on the input leads during a self-test. Long test leads can also act as an antenna causing pick-up of AC signals.

For optimum performance, all procedures should comply with the following recommendations:

- Assure that the calibration ambient temperature is stable and between 18 °C and 28 °C. Ideally the calibration should be performed at 23 °C ±1 °C.
- Assure ambient relative humidity is less than 80%.
- Allow a 2-hour warm-up period with a copper short connected and the multiplexer module installed before verification or adjustment. The connections are shown in the figure on page 76.
- Use shielded twisted pair Teflon® insulated cables to reduce settling and noise errors. Keep the input cables as short as possible.
- Connect the input cable shield to the source LO output. Except where noted in the procedures, connect the calibrator LO source to earth ground.

Two-wire Ohms measurements are affected by the entire path length, including the plug-in card trace length and slot trace lengths. On the 34901A, Channel 10 is recommended as the median path length (on the 34902A, use Channel 8) for 2-wire Ohms verification and adjustments. Install the input multiplexer in slot 200.

Because the instrument is capable of making highly accurate measurements, you must take special care to ensure that the calibration standards and test procedures used do not introduce additional errors. Ideally, the standards used to verify and adjust the instrument should be an order of magnitude more accurate than each instrument range full scale error specification.

For the DC voltage, DC current, and resistance gain verification measurements, you should take care to ensure the calibrator’s “0” output is correct. If necessary, the measurements can be referenced to the calibrator’s “0” output using $Mx + B$ scaling (see page 64). You will need to set the offset for each range of the measuring function being verified.

Performance Verification Tests

Use the Performance verification Tests to verify the measurement performance of the instrument. The performance verification tests use the instrument's specifications listed in chapter 1, "Specifications," starting on page 21.

You can perform four different levels of performance verification tests:

Self-Test A series of internal verification tests that give a high confidence that the instrument is operational.



Quick Verification A combination of the internal self-tests and selected verification tests.

Performance Verification Tests An extensive set of tests that are recommended as an acceptance test when you first receive the instrument or after performing adjustments.

Optional Verification Tests Tests *not* performed with every calibration. Perform these tests to verify additional specifications or functions of the instrument.

Self-Test

A brief power-on self-test occurs automatically whenever you turn on the instrument. This limited test assures that the instrument is capable of operation and also checks the plug-in cards for basic operation.

To perform a complete self-test hold down the  key as you press the power switch to turn on the instrument; *hold down the  key for more than 5 seconds until the instrument beeps* (a complete description of these tests can be found in chapter 6). The instrument will automatically perform the complete self-test procedure when you release the key. The self-test will complete in *approximately 20* seconds.

- If the self-test is successful, “PASS” is displayed on the front panel.
- If the self-test fails, “FAIL” is displayed and the **ERROR** annunciator turns on. If repair is required, see chapter 6, “Service,” for further details.
- If all tests pass, you have a high confidence (~90%) that the instrument is operational.

Quick Performance Check

The quick performance check is a combination of internal self-test and an abbreviated performance test (specified by the letter **Q** in the performance verification tests). This test provides a simple method to achieve high confidence in the instrument's ability to functionally operate and meet specifications. These tests represent the absolute minimum set of performance checks recommended following any service activity. Auditing the instrument's performance for the quick check points (designated by a **Q**) verifies performance for "normal" accuracy drift mechanisms. *This test does not check for abnormal component failures.*

To perform the quick performance check, do the following:

- Perform a complete self-test. A procedure is given on page 83.
- Perform only the performance verification tests indicated with the letter **Q**.

If the instrument fails the quick performance check, adjustment or repair is required.

Performance Verification Tests

The performance verification tests are recommended as acceptance tests when you first receive the instrument. The acceptance test results should be compared against the 90 day test limits. You should use the 24-hour test limits only for verification within 24 hours after performing the adjustment procedure. After acceptance, you should repeat the performance verification tests at every calibration interval.

If the instrument fails performance verification, adjustment or repair is required.

Adjustment is recommended at every calibration interval. If adjustment is not made, you must guard band, using no more than 80% of the specifications listed in Chapter 1, as the verification limits.

Internal DMM Verification Tests

These procedures use inputs connected to a 34901A 20-Channel Multiplexer (*see page 76*) installed in slot 200.

Zero Offset Verification

This procedure is used to check the zero offset performance of the internal DMM. Verification checks are only performed for those functions and ranges with unique offset calibration constants. Measurements are checked for each function and range as described in the procedure below.

Zero Offset Verification Procedure

- 1 Make sure you have read “Test Considerations” on page 81.
- 2 This procedure will measure the shorts installed on Channels 209 and 219. Leave the Amps input connections (Channel 221) open.

Continued on next page...

Chapter 4 Calibration Procedures
Internal DMM Verification Tests

...Continued from previous page

- 3 Select each function and range in the order shown in the table below. Before executing each test, you must press to enable reading monitoring on the selected channel (or use the ROUTE:MON command from the remote interface). Compare measurement results to the appropriate test limits shown in the table (see page 84).

Input	Channel 221		Quick Check	Error from Nominal		
	Function ^[1]	Range		24 hour	90 day	1 year
Open Open Open	DC Current	10 mA	Q	± 1 µA	± 2 µA	± 2 µA
		100 mA		± 4 µA	± 5 µA	± 5 µA
		1A		± 60 µA	± 100 µA	± 100 µA
Input	Channel 209		Quick Check	Error from Nominal		
	Function ^[1]	Range		24 hour	90 day	1 year
Short Short Short Short Short	DC Volts	100 mV	Q	± 3.5 µV	± 4 µV	± 4 µV
		1V		± 6 µV	± 7 µV	± 7 µV
		10V		± 40 µV	± 50 µV	± 50 µV
		100V		± 600 µV	± 600 µV	± 600 µV
		300V		± 6 mV	± 9 mV	± 9 mV
Short Short Short Short Short Short	2-Wire Ohms ^[2] and 4-Wire Ohms	100 Ω	Q	± 3.5 mΩ	± 4 mΩ	± 4 mΩ
		1 kΩ		± 6 mΩ	± 10 mΩ	± 10 mΩ
		10 kΩ		± 50 mΩ	± 100 mΩ	± 100 mΩ
		100 kΩ		± 500 mΩ	± 1 Ω	± 1 Ω
		1 MΩ		± 10 Ω	± 10 Ω	± 10 Ω
		10 MΩ		± 100 Ω	± 100 Ω	± 100 Ω
		100 MΩ	± 10 kΩ	± 10 kΩ	± 10 kΩ	

[1] Select 6½ digit resolution.

[2] for 2-wire ohms, an additional 4Ω of error must be added.

Q: Quick performance verification test points.

Note: Zero offset calibration using a multifunction calibrator is *NOT* recommended. The calibrator and cabling offset can be large and unstable causing poor offset calibration of the internal DMM.

Gain Verification

This procedure is used to check the “full scale” reading accuracy of the internal DMM. Verification checks are performed only for those functions and ranges with unique gain calibration constants. Begin verification by selecting a measuring function and range. *Make sure you have read “Test Considerations” on page 81.*

DC VOLTS, Resistance, and DC CURRENT Gain Verification Test

- 1 Make sure you have read “Test Considerations” on page 81.
- 2 Select each function and range in the order shown below. Before executing each test, you must press Mon to enable reading monitoring on the selected channel (or use the ROUTE:MON command from the remote interface).
- 3 Compare measurement results to the appropriate test limits shown in the table. (Be certain to allow for appropriate source settling.)

Input	Channel 210		Quick Check	Error from Nominal		
	Function ^[1]	Range		24 hour	90 day	1 year
-10 V 100 mV 1V 10V 100V 300V	DC Volts	10V	Q Q	± 190 µV	± 250 µV	± 400 µV
		100 mV		± 6.5 µV	± 8 µV	± 9 µV
		1V		± 26 µV	± 37 µV	± 47 µV
		10V		± 190 µV	± 250 µV	± 400 µV
		100V		± 2.6 mV	± 4.1 mV	± 5.1 mV
		300V		± 12 mV	± 19.5 mV	± 22.5 mV
100 Ω 1 kΩ 10 kΩ 100 kΩ 1 MΩ 10 MΩ 100 MΩ ^[3]	2-Wire Ohms ^[2] and 4-Wire Ohms	100 Ω 1 kΩ 10 kΩ 100 kΩ 1 MΩ 10 MΩ 100 MΩ	Q Q	± 6.5 mΩ ± 26 mΩ ± 250 mΩ ± 2.5 Ω ± 30 Ω ± 1.6 kΩ ± 310 kΩ	± 12 mΩ ± 90 mΩ ± 900 mΩ ± 9 Ω ± 90 Ω ± 2.1 kΩ ± 810 kΩ	± 14 mΩ ± 110 mΩ ± 1.1 Ω ± 11 Ω ± 110 Ω ± 4.1 kΩ ± 810 kΩ
Input	Channel 209		Quick Check	Error from Nominal		
	Function ^[1]	Range		24 hour	90 day	1 year
10 mA 100 mA 1 A	DC Current	10 mA	Q	± 1.5 µA	± 5 µA	± 7 µA
		100 mA		± 14 µA	± 35 µA	± 55 µA
		1A		± 560 µA	± 900 µA	± 1.1 mA

[1] Select 6½ digit resolution.

[2] The 2-wire ohms resistance verification test is optional (see note on Page 92). For 2-wire ohms, an additional 1Ω of error must be added (see Page 81). Add a 1-second channel delay when using Fluke 5700 in 2-wire compensated mode. This avoids response time issues with 2-wire compensation when 34970A/34972A's current source contains a pulse.

[3] Verify only, no adjustment required.

Q: Quick performance verification test points.

Chapter 4 Calibration Procedures
Internal DMM Verification Tests

AC VOLTS Gain Verification Test

Configuration: AC Volts
 LF 3 HZ:SLOW (in the *Advanced* menu)

- 1 Make sure you have read “Test Considerations” on page 81.
- 2 Select Channel 210, set the AC VOLTS function and the 3 Hz input filter. With the slow filter selected, each measurement takes 7 seconds to complete. Before executing each test, you must press Mon to enable reading monitoring on the selected channel (or use the ROUTe:MON command from the remote interface).
- 3 Select each range in the order shown below. Compare measurement results to the appropriate test limits shown in the table. (Be certain to allow for appropriate source settling.)

Input		Range	Quick Check	Error from Nominal		
V rms	Frequency			24 hour	90 day	1 year
100 mV	1 kHz	100 mV	Q	± 70 µV	± 90 µV	± 100 µV
100 mV	50 kHz			± 150 µV	± 160 µV	± 170 µV
1 V	1 kHz	1 V		± 700 µV	± 900 µV	± 1 mV
1 V	50 kHz	10 V	Q	± 1.5 mV	± 1.6 mV	± 1.7 mV
10 V	1 kHz			± 7 mV	± 9 mV	± 10 mV
10 V	50 kHz			± 15 mV	± 16 mV	± 17 mV
10 V	10 Hz	100 mV	Q	± 7 mV	± 9 mV	± 10 mV
10 mV ^[1]	1 kHz			± 34 µV	± 45 µV	± 46 µV
100 V	1 kHz			100 v	± 70 mV	± 90 mV
100 V	50 kHz	300V		± 150 mV	± 160 mV	± 170 mV
300 V	1 kHz			± 270 mV	± 390 mV	± 420 mV
300 V ^[2]	50 kHz			± 600 mV	± 690 mV	± 720 mV

[1] For this test, isolate the calibrator's output from earth ground.

[2] Some calibrators may have difficulty driving the internal DMM and cable load at this V-Hz output. Use short, low capacitance cable to reduce calibration loading. Verification can be performed at >195 Vrms. New test limits can be computed from the accuracy specification shown in Chapter 1 for the actual test conditions used.

Q: Quick performance verification test points.

Note: *The 50 kHz AC voltage test points may fail performance verification if the internal shields have been removed and reinstalled. See “Gain Adjustment,” on page 92, for further information on how to recalibrate the AC voltage function.*

AC CURRENT Gain Verification Test

Configuration: AC Current
LF 3 HZ:SLOW (in the *Advanced* menu)

- 1 Make sure you have read “Test Considerations” on page 81.
- 2 Select Channel 221, set the AC CURRENT function and the 3 Hz input filter. With the slow filter selected, each measurement takes 7 seconds to complete. Before executing each test, you must press **Mon** to enable reading monitoring on the selected channel (or use the ROUTE:MON command from the remote interface).
- 3 Select each range in the order shown below. Compare measurement results to the appropriate test limits shown in the table. (Be certain to allow for appropriate source settling.)

Input		Range	Quick Check	Error from Nominal		
Current	Frequency			24 hour	90 day	1 year
10 mA ^[1]	1 kHz	10 mA	Q	± 14 µA	± 14 µA	± 14 µA
100 mA ^[1]	1 kHz	100 mA		± 600 µA	± 600 µA	± 600 µA
10 mA	1 kHz	1 A		± 1.41 mA	± 1.41 mA	± 1.41 mA
1 A ^[1]	1 kHz	1 A		± 1.4 mA	± 1.4 mA	± 1.4 mA

[1] Verify only, no adjustment.

Frequency Gain Verification Test

Configuration: Frequency
6½ digits

- 1 Make sure you have read “Test Considerations” on page 81.
- 2 Select Channel 210, select the FREQUENCY function and set 6½ digits.
- 3 Select each range in the order shown below. Compare measurement results to the appropriate test limits shown in the table. (Be certain to allow for appropriate source settling.)

Input		Range	Quick Check	Error from Nominal		
Voltage	Frequency			24 hour	90 day	1 year
10 mV ^[1]	100 Hz	100 mV	Q	± 0.06 Hz	± 0.1 Hz	± 0.1 Hz
1 V	100 kHz	1 V		± 6 Hz	± 10 Hz	± 10 Hz

[1] Verify only, No adjustment. For this test, isolate the calibrator's output from earth ground.

Q: Quick performance verification test points.

Optional AC Performance Verification Tests

These tests are *not* intended to be performed with every calibration. They are provided as an aid for verifying additional instrument specifications. There are *no adjustments* for these tests; they are provided for performance verification only.

Configuration: AC Volts
 LF 3 HZ:SLOW (in the *Advanced* menu)

- 1 Make sure you have read “Test Considerations” on page 81.
- 2 Select Channel 210, select the AC Volts function and the 3 HZ filter. Before executing each test, you must press Mon to enable reading monitoring on the selected channel (or use the ROUTe:MON command from the remote interface).
- 3 Select each range in the order shown below. Compare measurement results to the appropriate test limits shown in the table. (Be certain to allow for appropriate source settling.)

Input		Range	Error from Nominal		
Voltage	Frequency		24 hour	90 day	1 year
1 V	20 Hz	1 V	± 700 μV	± 900 μV	± 1 mV
1 V	20 kHz	1 V	± 700 μV	± 900 μV	± 1 mV
1 V	100 kHz	1 V	± 6.3 mV	± 6.8 mV	± 6.8 mV
1 V	200 kHz	1 V	± 45 mV	± 45 mV	± 45 mV
1 V	250 kHz	1 V	± 45 mV	± 45 mV	± 45 mV
1 V	300 kHz	1 V	± 45 mV	± 45 mV	± 45 mV
10 V	1 kHz	10 V	± 7 mV	± 9 mV	± 10 mV
1 V	1 kHz	10 V	± 3.4 mV	± 4.5 mV	± 4.6 mV
100 mV	1 kHz	10 V	± 13 mV	± 14 mV	± 14.06 mV

Internal DMM Adjustments

You will need a 34901A 20-Channel Multiplexer to perform the following procedures (see page 76). Install the Multiplexer in slot 200.

Zero Adjustment

Each time you perform a zero adjustment, the Internal DMM stores a new set of offset correction constants for every measurement function and range. The Internal DMM will sequence through all required functions and ranges automatically and store new zero offset calibration constants. All offset corrections are determined automatically. *You may not correct a single range or function without re-entering ALL zero offset correction constants automatically. This feature is intended to save calibration time and improve zero calibration consistency.*

Note: *Never turn off the Internal DMM during Zero Adjustment. This may cause ALL calibration memory to be lost.*

Zero Adjustment Procedure

The zero adjustment procedure takes about 5 minutes to complete. Be sure to allow the instrument to warm up for 2 hours before performing the adjustments.

Follow the steps outlined below. Review “Test Considerations” on page 81 before beginning this test. Also see page 63, for an example of how to initiate a zero calibration.

- 1 This procedure will use the copper shorts installed on Channels 209 and 219. Leave the Amps input connections (Channel 221) open.
- 2 Select Channel 209. Select the DC VOLTS function.
- 3 Press **Shift** **View** to enter the calibration menu. Press **View** again to begin the adjustment procedure.
- 4 Use the knob and arrow keys to set the number in the display to 0.000000 and press **View**.
- 5 Perform the Zero Offset Verification tests (see page 85) to check zero calibration results.

Gain Adjustment

The Internal DMM stores a *single* new gain correction constant each time this procedure is followed. The gain constant is computed from the calibration value entered for the calibration command and from measurements made automatically during the adjustment procedure.

Most measuring functions and ranges have gain adjustment procedures. Only the 100 M Ω range *does not* have gain calibration procedures. The gain calibration value may be entered through the front panel menu or over the remote interface. See page 63, for an example of how to enter calibration values.

Adjustments for each function should be performed **ONLY** in the order shown in the performance verification table. See “Performance Verification Tests” earlier in this chapter for the tables used for gain adjustments.

Gain Adjustment Considerations

- The zero adjustment procedure *must* have been recently performed prior to beginning any gain adjustment procedures.
- The optional –10 VDC adjustment should be performed *only* after servicing the Internal DMM’s a-to-d converter or after replacing network A4U101 or calibration RAM A4U505.
- When performing a 4-wire ohms gain adjustment, a new gain correction constant is *also stored* for the corresponding 2-wire ohms measurement range. If desired, the 2-wire gain can be adjusted separately *after* the 4-wire ohms gain calibration is completed.
- During the AC voltage gain adjustments, some of the DC voltage gain constants are used. Perform the DC voltage gain calibration before the AC voltage gain calibration.

Note: *Never turn off the instrument during a Gain Adjustment. This may cause calibration memory for the present function to be lost.*

Valid Gain Adjustment Input Values

Gain adjustment can be accomplished using the following input values.

Function	Range	Valid Calibration Input Values
DC VOLTS	100 mV to 100 V 300 V	0.9 to 1.1 x Full Scale 250 V to 303 V
OHMS, OHMS 4W	100Ω to 10 MΩ	0.9 to 1.1 x Full Scale
DC CURRENT	10 mA to 1 A	0.9 to 1.1 x Full Scale
AC VOLTS ^[1]	10 mV to 100 V 300 V	0.9 to 1.1 x Full Scale 95 V to 303 V
AC CURRENT	1 A	9 mA to 11 mA
Frequency	Any	Any Input >100 mV rms, 1 kHz - 100 kHz

[1] Valid frequencies are as follows: 1 kHz ± 10% for the 1 kHz calibration,
45 kHz - 100 kHz for the 50 kHz calibration,
and 10 Hz ± 10% for the 10 Hz calibration.



Gain Adjustment Procedure



Adjustment for each function should be performed *only* in the order shown in the performance verification table. The performance verification tables used for gain adjustments start on page 87.

Review the “Test Considerations” (page 81) and “Gain Adjustment” (page 92) sections before beginning this test.



Configuration: DC functions — 6½ digits
AC functions — LF 3 HZ:SLOW (in the *Advanced* menu)

- 1 Select Channel 210. Configure the channel to each function and range shown in the gain verification tables (*pages 85 – 79*).
- 2 Apply the input signal shown in the “Input” column of the appropriate verification table.

Note: *Always complete tests in the same order as shown in the appropriate verification table.*

- 3 Press   to enter the calibration menu. Press  again to begin the adjustment procedure.



- 4 Use the knob, and  and  to set the number in the display to the actual input value and press .
- 5 Perform the appropriate Gain Verification Test to check the calibration results.
- 6 Repeat steps 1 through 6 for each gain verification test point shown in the tables.

Note: *Each range in the gain adjustment procedure takes less than 20 seconds to complete.*







–10 VDC Adjustment Procedure (Optional)

The –10 VDC calibration electronically enhances the Internal DMM's a-to-d converter linearity characteristic. *This adjustment should ONLY be performed after servicing the A-to-D converter or replacement of the calibration RAM.*

You will need a 34901A 20-Channel Multiplexer to perform the following procedures (see page 76). Install the Multiplexer in slot 200.

- 1 If a zero calibration has not been performed recently, perform one before beginning this procedure (see page 91).
- 2 Select Channel 210. Configure the channel as follows:
 - DC VOLTS
 - 10 V range
 - 6½ digits
 - INTEG 100 PLC (in the *Advanced* menu)
 - INPUT R > 10 G (in the *Advanced* menu)

Before executing each test, you must press  to enable reading monitoring on the selected channel (or use the ROUTE:MON command from the remote interface).







- 3 Measure and note the voltage offset present at the end of the measurement cable by shorting the ends of the Channel 210 measurement cable. Be sure to use a copper wire and allow enough time for the residual thermal offset to stabilize (usually about 1 minute).
- 4 Connect the input cable to the calibrator output and set the calibrator to output +10V. Allow enough settling time for any thermal offset voltages to stabilize (usually about 1 minute).
- 5 Perform a +10V DC gain calibration. Press   to enter the calibration menu. Press  again to begin the adjustment procedure.
- 6 Use the knob,  and  to set the number in the display to the sum of the calibrator output and the measured offset (from step 3) and press . For example, if the calibrator output is 10.001 volts and the measured offset is 10 µV, enter +10.001010 volts. When the adjustment finishes, verify that new readings fall within ± 20 µV of the calibrator output plus the offset.



Continued on next page...

Chapter 4 Calibration Procedures
-10 VDC Adjustment Procedure (Optional)

...Continued from previous page

- 7 Reverse the cable connections to the calibrator to create a -10 VDC voltage standard. You *must* physically reverse the cables. *DO NOT switch the output polarity of the calibrator.*
- 8 Perform a -10V DC gain calibration. Press   to enter the calibration menu. Press  again to begin the adjustment procedure. Be sure to allow time for thermal offsets to stabilize (usually about 1 minute).
- 9 Use the knob,  and  to set the number in the display to the *difference* of the calibrator output and the measured offset (from step 3) and press . Using the previous example values, enter 10 μ V minus 10.001 volts or -10.000990 volts.
- 10 When the adjustment finishes, verify that new readings fall within $\pm 30 \mu$ V of the calibrator output minus the offset.

Plug-in Module Test Considerations

For optimum performance, all test procedures should comply with the following recommendations:

- Assure that the calibration ambient temperature is stable and between 18 °C and 28 °C. Ideally the calibration should be performed at 23 °C ± 1 °C.
- Assure ambient relative humidity is less than 80%.
- Install the plug-in module and allow a 45 minute warm-up period before verification or adjustment.
- Use shielded twisted pair Teflon® insulated cables to reduce settling and noise errors. Keep the input cables as short as possible.
- Remove all user wiring and connections from the plug-in modules before verification or adjustment.
- Use 4-wire Ohms measurement techniques for checking relay contact resistance. Check directly at the terminals where possible.

Relay Verification

There are two methods you can use to verify relays:

- Read the relay cycle count.
- Measure the relay contact resistance.

Relay Cycle Count

The instrument has a *Relay Maintenance System* to help you predict relay end-of-life. The instrument counts the cycles on each relay in the instrument and stores the total count in non-volatile memory on each switch module. You can use this feature on any of the relay modules and the internal DMM.

- In addition to the channel relays, you can also query the count on backplane relays and bank relays. Note that you cannot control the state of these relays from the front panel but you can query the count.
- You can also query the state of the three relays on the internal DMM. These relays are numbered “1”, “2”, and “3” (which correspond to relays K102, K103, and K104 respectively). These relays open or close when a function or range is changed on a module.
- The 34908A multiplexer contains 40 channels which are switched (HI only) using only 20 relays. Each relay is used to switch HI on two different channels (and only one channel can be closed at a time). The channels are arranged such that channels 01 and 21 use different contacts on the same relay. The remaining channels are also paired in the same manner (Channels 02 and 22, Channels 03 and 23, etc.). Therefore, when you query the relay count on a channel, the number reflects the number of times that the relay was closed. For example, the relay count will always be the same on Channels 01 and 21.
- You can reset the count (allowed only from remote) but the instrument must be unsecured (see “*To Unsecure for Calibration*” on page 60 to unsecure the instrument).
- For more information on relay life and load considerations, refer to “Relay Life and Preventative Maintenance” in Chapter 8 of the *34970A/34972A User’s Guide*.
- A procedure to read the relay cycle count is given on page 65.

(Optional) 34901A Relay Contact Resistance Verification

This optional procedure uses an external DMM to make 4-wire ohms measurements across the relay contacts on the 34901A. The measured resistance is the series resistance of the two relay contacts (both contacts are in the same relay).

Note: Be sure to read “Plug-in Module Test Considerations” on page 97.

Tests 1 - 5:

See the diagram on page 100 for the required connections for each test (be sure to probe the components at the indicated location). For these measurements, the 34901A is not installed in the 34970A/34972A.

Record the

4-wire ohms measurements from the external DMM in the table below.

Note: The connections to the external DMM are different for each of Tests 1, 2, 4, and 5. Be sure to verify the connections shown in the table below for each of the four tests.

External DMM Ohmmeter Connections					
Test #	HI	LO	HI Sense	LO Sense	Measured Value
1	L401	J101, C14	L401	J101, C14	_____ Ohms
2	L402	J101, C15	L402	J101, C15	_____ Ohms
3	Add (Test 1 + Test 2)				_____ Ohms
4	F501	C21 I	F501	C21 I	_____ Ohms
5	F502	C22 I	F502	C22 I	_____ Ohms

Chapter 4 Calibration Procedures

Relay Verification

Note: Connect bare copper wires (approximately 3 cm in length) to the I terminals of Channels 21 and 22 as shown below. These wires will be used to make shorts across the channels in Tests 6 through 39.

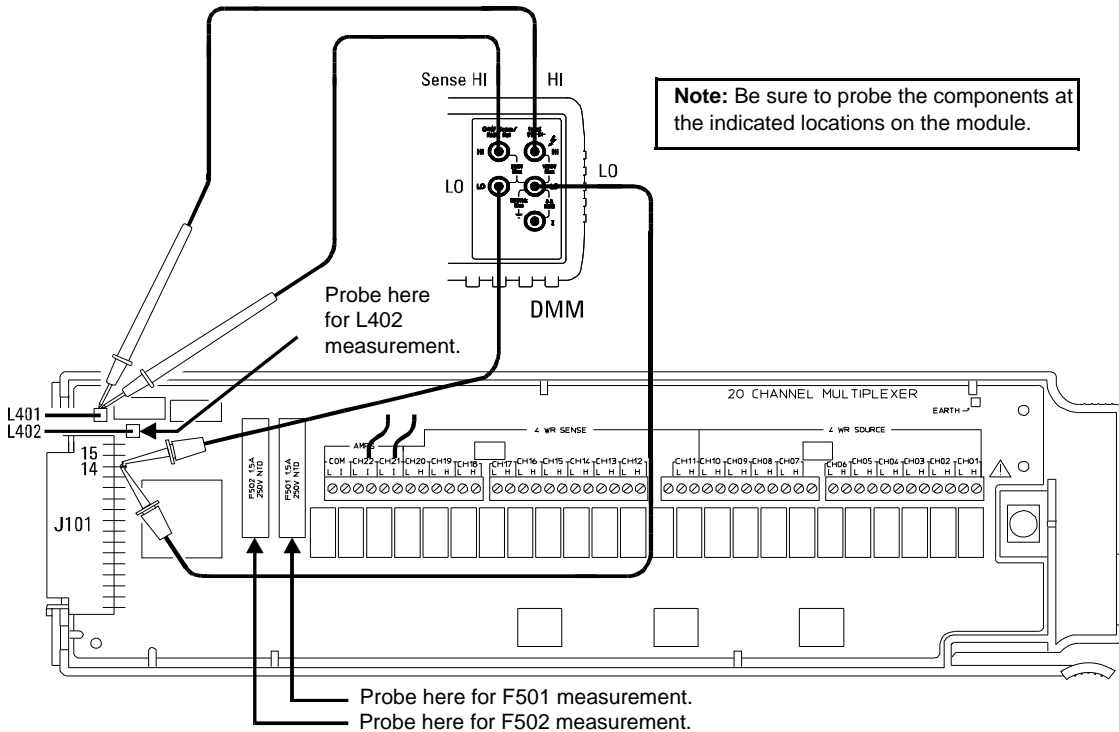

Connections for 34901A Verification Tests 1 through 5

Tests 6 - 8:

Make the connections to the 34901A as shown in the diagram below. Be sure to route your wiring for proper strain relief and install the module cover. Install the 34901A in slot 200 of the 34970A/34972A. Open all channels on the module by performing a Factory Reset (press **Sto/Rcl** and select "Recall State"; press **Sto/Rcl** again and select "Factory Reset"). Configure Channel 20 as follows: DC volts, 10 volt range, and 5½ digits

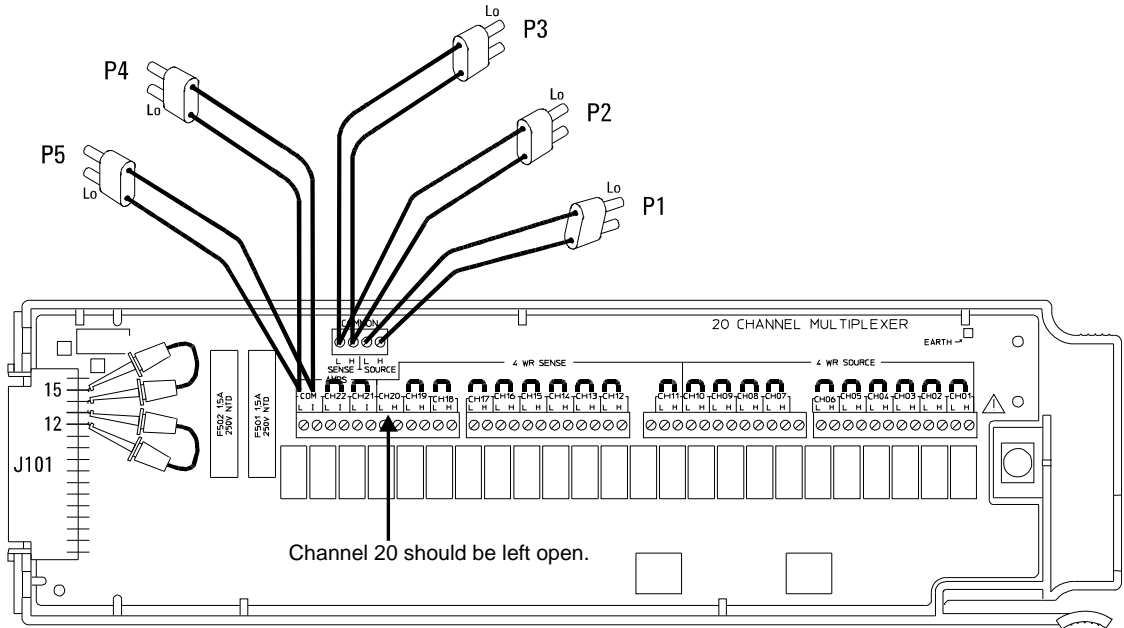

.Connections for 34901A Verification Tests 6 through 39

Enable reading monitoring by pressing **Mon** on the selected channel (or use the ROUTE:MON command). Record the 4-wire ohms measurements from the external DMM in the following table.

External DMM Ohmmeter Connections								
Test #	Channel Configured	HI	LO	HI Sense	LO Sense	Measured Value	Test Limit	Relay Measured
6	Ch 20	P2	P2	P1	P1	_____ Ohms	2.00Ω	K421
7	Ch 20	P2	P2	P3	P3	_____ Ohms	—	—
8	Subtract (Test 7 - Test 6)					_____ Ohms	2.00Ω	K422

Chapter 4 Calibration Procedures
Relay Verification

Tests 9 - 10:

Open all channels on the module by performing a Factory Reset. Configure Channel 10 (module in slot 200) as follows: 4-wire ohms, 1 k Ω range, and 5½ digits.

Enable reading monitoring by pressing Mon on the selected channel (or use the ROUTe:MON command). Record the 4-wire ohms measurements from the external DMM in the following table.

External DMM Ohmmeter Connections								
Test #	Channel Configured	HI	LO	HI Sense	LO Sense	Measured Value	Test Limit	Relay Measured
9	Ch 10	P2	P2	P3	P3	_____ Ohms	—	—
10	Subtract (Test 9 - Test 3)					_____ Ohms	2.00 Ω	K423

Tests 11- 33:

Open all channels on the module by performing a Factory Reset. For each test, close *only* the channel shown in the “Channel Closed” column below (module in slot 200). Turn the Monitor Mode “off” and select “Banks Joined” from the *Advanced* menu. Record the 4-wire ohms measurements from the external DMM in the following table.

External DMM Ohmmeter Connections								
Test #	Channel Closed*	HI	LO	HI Sense	LO Sense	Measured Value	Test Limit	Relay Measured
11	Ch1	P2	P2	P1	P1	_____ Ohms	2.00 Ω	K401
12	Ch 2	P2	P2	P1	P1	_____ Ohms	2.00 Ω	K402
13	Ch 3	P2	P2	P1	P1	_____ Ohms	2.00 Ω	K403
14	Ch 4	P2	P2	P1	P1	_____ Ohms	2.00 Ω	K404
15	Ch 5	P2	P2	P1	P1	_____ Ohms	2.00 Ω	K405
16	Ch 6	P2	P2	P1	P1	_____ Ohms	2.00 Ω	K406
17	Ch 7	P2	P2	P1	P1	_____ Ohms	2.00 Ω	K407

*Only the channel currently under test should be closed at one time. All other channels should be open.

Continued on next page...

...Continued from previous page

External DMM Ohmmeter Connections								
Test #	Channel Closed*	HI	LO	HI Sense	LO Sense	Measured Value	Test Limit	Relay Measured
18	Ch 8	P2	P2	P1	P1	_____ Ohms	2.00Ω	K408
19	Ch 9	P2	P2	P1	P1	_____ Ohms	2.00Ω	K409
20	Ch 10	P2	P2	P1	P1	_____ Ohms	2.00Ω	K410
21	Ch 11	P2	P2	P1	P1	_____ Ohms	2.00Ω	K411
22	Ch 12	P2	P2	P1	P1	_____ Ohms	2.00Ω	K412
23	Ch 13	P2	P2	P1	P1	_____ Ohms	2.00Ω	K413
24	Ch 14	P2	P2	P1	P1	_____ Ohms	2.00Ω	K414
25	Ch 15	P2	P2	P1	P1	_____ Ohms	2.00Ω	K415
26	Ch 16	P2	P2	P1	P1	_____ Ohms	2.00Ω	K416
27	Ch 17	P2	P2	P1	P1	_____ Ohms	2.00Ω	K417
28	Ch 18	P2	P2	P1	P1	_____ Ohms	2.00Ω	K418
29	Ch 19	P2	P2	P1	P1	_____ Ohms	2.00Ω	K419
30	Ch 21	P4	P4	P5	P5	_____ Ohms	—	—
31	Subtract (Test 30 - Test 4)					_____ Ohms	2.00Ω	K522
32	Ch 22	P4	P4	P5	P5	_____ Ohms	—	—
33	Subtract (Test 32 - Test 5)					_____ Ohms	2.00Ω	K522

*Only the channel currently under test should be closed at one time. All other channels should be open.

Chapter 4 Calibration Procedures
Relay Verification

Tests 34 - 36: Close *only* channels Channels 20 and 22. Remove the 34901A from the 34970A/34972A and do not reinstall it for these tests.

On connector J101, remove the jumper between pins C14 and C15 (the *top* jumper shown in the diagram on page 101). On the remaining jumper connected to J101 (the *bottom* jumper shown in the diagram), move the end of the jumper from pin C12 to pin C16; the jumper should now short pins C13 and C16 together.

Cut, but do not remove, the copper shorts on Channels 21 and 22 (the wires will be used for the 4-wire ohms measurements below). Add a copper short between the L and H terminals on Channel 20. Record the measured value as *Test 34* in the table below.

Using the external DMM, make a 4-wire ohms measurement between the L and I terminals on Channel 21. Record the measured value as *Test 35* in the table below.

External DMM Ohmmeter Connections								
Test #	Channel Closed	HI	LO	HI Sense	LO Sense	Measured Value	Test Limit	Relay Measured
34	Ch 20*	P3	P3	P2	P2	_____ Ohms	2.00Ω	K420
35	Ch 22*	Ch 21 I	Ch 21 L	Ch 21 I	Ch 21 L	_____ Ohms	—	—
36	Subtract (Test 35 - Test 4)					_____ Ohms	2.00Ω	K523

*The latching relays remain closed when the module is removed from the 34970A/34972A.

Test 37: Install the 34901A in slot 200 of the 34970A/34972A. Select and configure Channel 21 as follows: DC current, 1 amp range, and 5½ digits. Enable reading monitoring by pressing **Mon** on the selected channel (or use the ROUTe:MON command). Record the 4-wire ohms measurement from the external DMM in the following table.

		External DMM Ohmmeter Connections						
Test #	Channel Configured	HI	LO	HI Sense	LO Sense	Measured Value	Test Limit	Relay Measured
37	Ch 21	P4	P4	P5	P5	_____ Ohms	2.00Ω	K521

Tests 38 - 39: Open all channels on the module by performing a Factory Reset. Close Channel 21 (module in slot 200). Remove the 34901A from the 34970A/34972A and do not reinstall it for the remaining tests. Using the external DMM, make a 4-wire ohms measurement between the L and I terminals on Channel 22. Record the measured value as *Test 38* in the following table.

		External DMM Ohmmeter Connections						
Test #	Channel Closed	HI	LO	HI Sense	LO Sense	Measured Value	Test Limit	Relay Measured
38	Ch 21	Ch 22 I	Ch 22 L	Ch 22 I	Ch 22 L	_____ Ohms	—	—
39	Subtract (Test 38 - Test 5)					_____ Ohms	2.00Ω	K524

(Optional) 34902A Relay Contact Resistance Verification

This optional procedure uses an external DMM to make 4-wire ohms measurements across the relay contacts on the 34902A. The measured resistance is the series resistance of the two relay contacts (both contacts are in the same relay).

Note: *Be sure to read “Plug-in Module Test Considerations” on page 97.*

Tests 1 - 4:

See the diagram on page 107 for the required connections for each test (be sure to probe the components at the indicated location). For these measurements, the 34902A is not installed in the 34970A/34972A. Record the 4-wire ohms measurements from the external DMM in the table below.

Note: *The connections to the external DMM are different for each of Tests 1, 2, and 3. Be sure to verify the connections shown in the table below for each of the three tests.*

External DMM Ohmmeter Connections					
Test #	HI	LO	HI Sense	LO Sense	Measured Value
1	L300	J101, C12	L300	J101, C12	_____ Ohms
2	L301	J101, C14	L301	J101, C14	_____ Ohms
3	L302	J101, C15	L302	J101, C15	_____ Ohms
4	Add (Test 2 + Test 3)				_____ Ohms

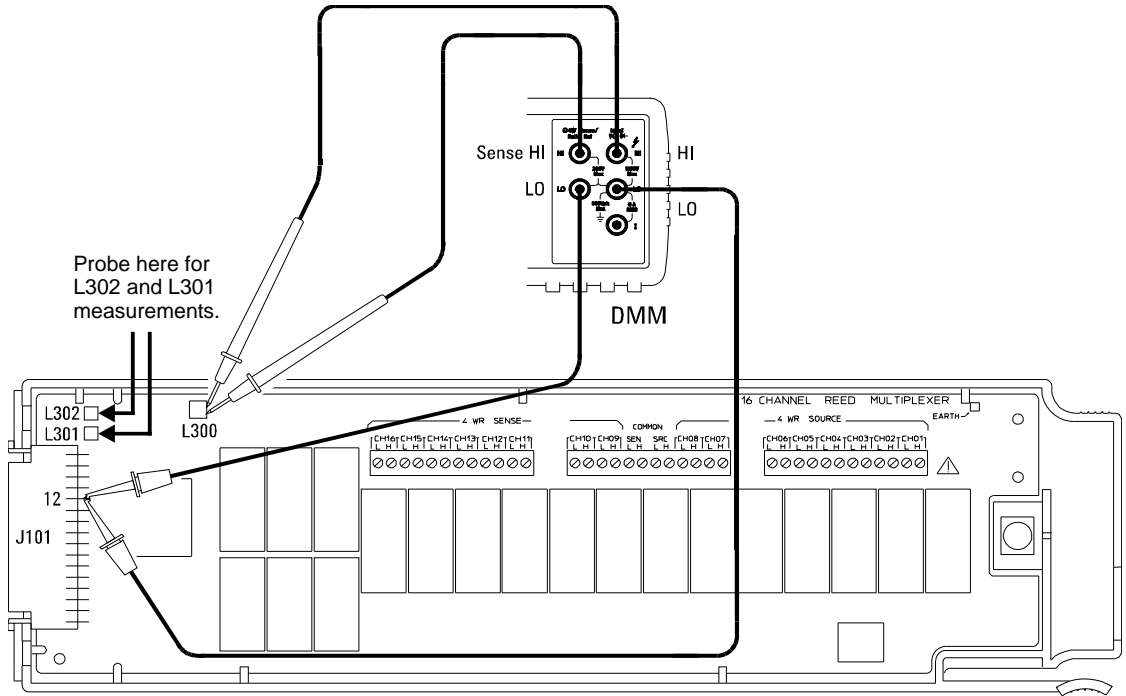

Connections for 34902A Verification Tests 1 through 4

Chapter 4 Calibration Procedures
Relay Verification

Tests 5 - 8:

Make the connections to the 34902A as shown in the diagram below. Be sure to route your wiring for proper strain relief and install the module cover. Install the 34902A in slot 200 of the 34970A/34972A. Open all channels on the module by performing a Factory Reset (press **Sto/Rcl** and select “Recall State”; press **Sto/Rcl** again and select “Factory Reset”). Configure Channel 16 as follows: DC volts, 10 volt range, and 5½ digits.

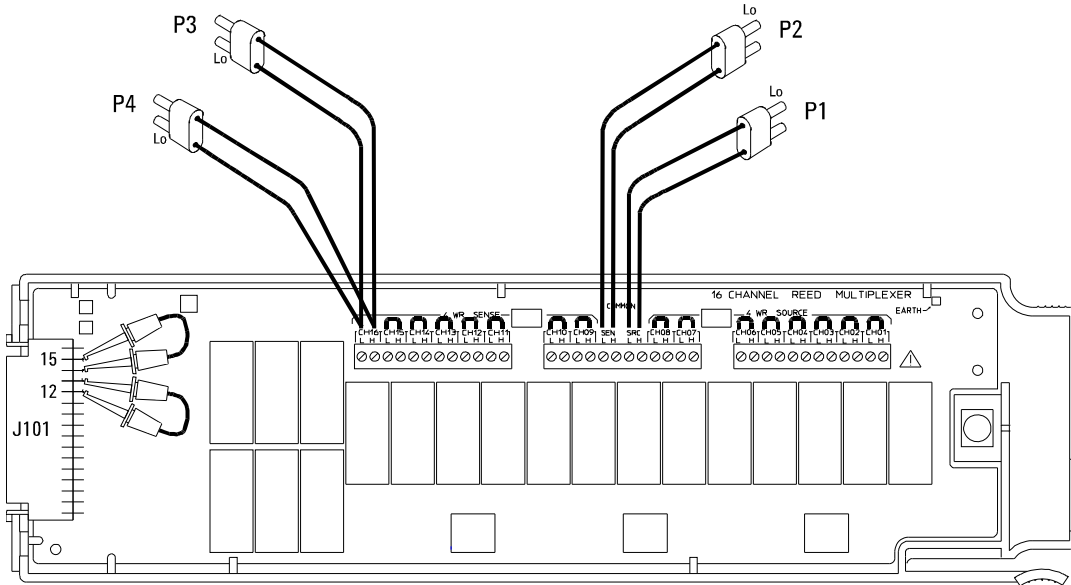

Connections for 34902A Verification Tests 5 through 27

Enable reading monitoring by pressing **Mon** on the selected channel (or use the ROUTe:MON command). Record the 4-wire ohms measurements from the external DMM in the following table.

External DMM Ohmmeter Connections								
Test #	Channel Configured	HI	LO	HI Sense	LO Sense	Measured Value	Test Limit	Relay Measured
5	Ch 16	P3	P3	P1	P1	_____ Ohms	—	—
6	Subtract (Test 5 - Test 1)					_____ Ohms	2.00Ω	K326
7	Ch 16	P3	P3	P2	P2	_____ Ohms	—	—
8	Subtract (Test 7 - Test 5)						2.00Ω	K327

Tests 9 - 10:

Open all channels on the module by performing a Factory Reset. Configure Channel 08 (module in slot 200) as follows: 4-wire ohms, 1 kΩ range, and 5½ digits.

Enable reading monitoring by pressing Mon on the selected channel (or use the ROUTe:MON command). Record the 4-wire ohms measurements from the external DMM in the following table.

External DMM Ohmmeter Connections								
Test #	Channel Configured	HI	LO	HI Sense	LO Sense	Measured Value	Test Limit	Relay Measured
9	Ch 08	P3	P3	P2	P2	_____ Ohms	—	—
10	Subtract (Test 9 - Test 4					_____ Ohms	2.00Ω	K328

Tests 11 - 27:

Open all channels on the module by performing a Factory Reset. For each test, close *only* the channels shown in the “Channels Closed” column below (module in slot 200). Turn the Monitor Mode “off” and select “Banks Joined” from the *Advanced* menu. Record the 4-wire ohms measurements from the external DMM in the following table.

External DMM Ohmmeter Connections								
Test #	Channel Closed*	HI	LO	HI Sense	LO Sense	Measured Value	Test Limit	Relay Measured
11	Ch 16 & 1	P3	P3	P1	P1	_____ Ohms	2.00Ω	K301
12	Ch 16 & 2	P3	P3	P1	P1	_____ Ohms	2.00Ω	K302
13	Ch 16 & 3	P3	P3	P1	P1	_____ Ohms	2.00Ω	K303
14	Ch 16 & 4	P3	P3	P1	P1	_____ Ohms	2.00Ω	K304
15	Ch 16 & 5	P3	P3	P1	P1	_____ Ohms	2.00Ω	K305

*Only the channel currently under test should be closed at one time. All other channels should be open.

Continued on next page...

Chapter 4 Calibration Procedures
Relay Verification

...Continued from previous page

Test #	Channel Closed*	External DMM Ohmmeter Connections				Measured Value	Test Limit	Relay Measured
		HI	LO	HI Sense	LO Sense			
16	Ch 16 & 6	P3	P3	P1	P1	_____ Ohms	2.00Ω	K306
17	Ch 16 & 7	P3	P3	P1	P1	_____ Ohms	2.00Ω	K307
18	Ch 16 & 8	P3	P3	P1	P1	_____ Ohms	2.00Ω	K308
19	Ch 16 & 9	P3	P3	P1	P1	_____ Ohms	2.00Ω	K309
20	Ch 16 & 10	P3	P3	P1	P1	_____ Ohms	2.00Ω	K310
21	Ch 16 & 11	P3	P3	P1	P1	_____ Ohms	2.00Ω	K311
22	Ch 16 & 12	P3	P3	P1	P1	_____ Ohms	2.00Ω	K312
23	Ch 16 & 13	P3	P3	P1	P1	_____ Ohms	2.00Ω	K313
24	Ch 16 & 14	P3	P3	P1	P1	_____ Ohms	2.00Ω	K314
25	Ch 16 & 15	P3	P3	P1	P1	_____ Ohms	2.00Ω	K315
26	Ch 16 & 15	P3	P3	P4	P4	_____ Ohms	2.00Ω	—
27	Subtract (Test 26 - Test 25)					_____ Ohms	2.00Ω	K316

*Only the channel currently under test should be closed at one time. All other channels should be open.

(Optional) 34903A Relay Contact Resistance Verification

- 1 Be sure to read “Plug-in Module Test Considerations” on page 97.
- 2 Install the 34903A module in slot 100. Close Channels 01 through 20. Remove the module from the 34970A/34972A.
- 3 Measure the resistance from the CM terminal to the NO terminal on each channel.
- 4 Install the module in slot 100. Open Channel 01 through 20. Remove the module from the 34970A/34972A.
- 5 Measure the resistance from the CM terminal to the NC terminal on each channel.

Note: *In general, a new relay should have a contact resistance of less than 0.2Ω . Relays with contact resistance in excess of 1.2Ω should be replaced.*

(Optional) 34904A Relay Contact Resistance Verification

This optional procedure uses an external DMM to make 4-wire ohms measurements across the relay contacts on the 34904A.

- 1 Be sure to read “Plug-in Module Test Considerations” on page 97.
- 2 Connect coppers shorts from H to L on each of the eight columns (COL1 through COL8) as shown below. Connect four dual banana plugs to the four rows as shown below (ROW1 through ROW4). Be sure to route your wiring for proper strain relief and install the module cover. Install the 34904A in slot 200 of the 34970A/34972A.

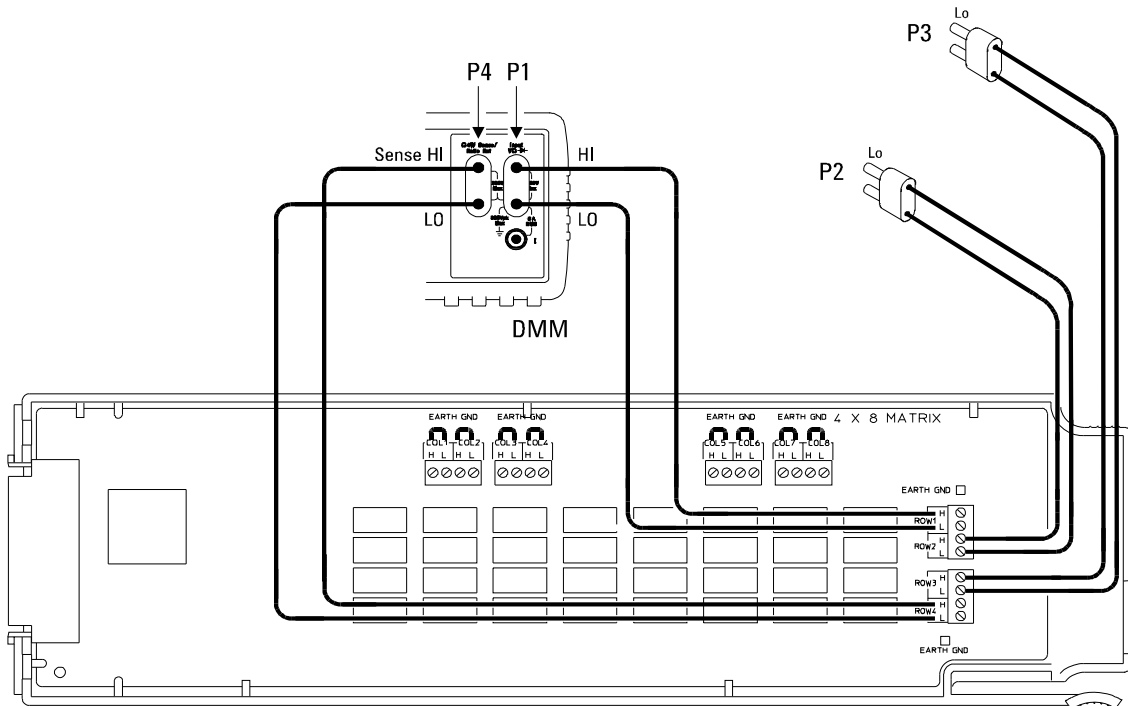

Connections for 34904A Verification Tests

Tests 1 - 32:

Open all channels on the module by performing a Factory Reset (press **Sto/Rel** and select “Recall State”; press **Sto/Rel** again and select “Factory Reset”). For each test, close *only* the channels shown in the “Channels Closed” column below (module in slot 200). Record the 4-wire ohms measurements from the external DMM in the following table.

Note: To prepare the module between tests, press and hold down until “Card Reset” **Card Reset** is displayed on the front panel.

		External DMM Ohmmeter Connections						
Test #	Channel Closed*	HI	LO	HI Sense	LO Sense	Measured Value	Test Limit	Relay Measured
1	Ch 11 & 41	P1	P1	P4	P4	_____ Ohms	2.00Ω	K101
2	Ch 12 & 42	P1	P1	P4	P4	_____ Ohms	2.00Ω	K102
3	Ch 13 & 43	P1	P1	P4	P4	_____ Ohms	2.00Ω	K103
4	Ch 14 & 44	P1	P1	P4	P4	_____ Ohms	2.00Ω	K104
5	Ch 15 & 45	P1	P1	P4	P4	_____ Ohms	2.00Ω	K105
6	Ch 16 & 46	P1	P1	P4	P4	_____ Ohms	2.00Ω	K106
7	Ch 17 & 47	P1	P1	P4	P4	_____ Ohms	2.00Ω	K107
8	Ch 18 & 48	P1	P1	P4	P4	_____ Ohms	2.00Ω	K108
9	Ch 21 & 41	P2	P2	P4	P4	_____ Ohms	2.00Ω	K201
10	Ch 22 & 42	P2	P2	P4	P4	_____ Ohms	2.00Ω	K202
11	Ch 23 & 43	P2	P2	P4	P4	_____ Ohms	2.00Ω	K203
12	Ch 24 & 44	P2	P2	P4	P4	_____ Ohms	2.00Ω	K204
13	Ch 25 & 45	P2	P2	P4	P4	_____ Ohms	2.00Ω	K205
14	Ch 26 & 46	P2	P2	P4	P4	_____ Ohms	2.00Ω	K206
15	Ch 27 & 47	P2	P2	P4	P4	_____ Ohms	2.00Ω	K207
16	Ch 28 & 48	P2	P2	P4	P4	_____ Ohms	2.00Ω	K208

*Only the channel currently under test should be closed at one time. All other channels should be open.

Continued on next page...

Chapter 4 Calibration Procedures
Relay Verification

...Continued from previous page

Test #	Channel Closed*	External DMM Ohmmeter Connections				Measured Value	Test Limit	Relay Measured
		HI	LO	HI Sense	LO Sense			
17	Ch 31 & 41	P3	P3	P4	P4	_____ Ohms	2.00Ω	K301
18	Ch 32 & 42	P3	P3	P4	P4	_____ Ohms	2.00Ω	K302
19	Ch 33 & 43	P3	P3	P4	P4	_____ Ohms	2.00Ω	K303
20	Ch 34 & 44	P3	P3	P4	P4	_____ Ohms	2.00Ω	K304
21	Ch 35 & 45	P3	P3	P4	P4	_____ Ohms	2.00Ω	K305
22	Ch 36 & 46	P3	P3	P4	P4	_____ Ohms	2.00Ω	K306
23	Ch 37 & 47	P3	P3	P4	P4	_____ Ohms	2.00Ω	K307
24	Ch 38 & 48	P3	P3	P4	P4	_____ Ohms	2.00Ω	K308
25	Ch 41 & 11	P4	P4	P1	P1	_____ Ohms	2.00Ω	K401
26	Ch 42 & 12	P4	P4	P1	P1	_____ Ohms	2.00Ω	K402
27	Ch 43 & 13	P4	P4	P1	P1	_____ Ohms	2.00Ω	K403
28	Ch 44 & 14	P4	P4	P1	P1	_____ Ohms	2.00Ω	K404
29	Ch 45 & 15	P4	P4	P1	P1	_____ Ohms	2.00Ω	K405
30	Ch 46 & 16	P4	P4	P1	P1	_____ Ohms	2.00Ω	K406
31	Ch 47 & 17	P4	P4	P1	P1	_____ Ohms	2.00Ω	K407
32	Ch 48 & 18	P4	P4	P1	P1	_____ Ohms	2.00Ω	K408

*Only the channel currently under test should be closed at one time. All other channels should be open.

(Optional) 34905/06A Relay Contact Resistance Verification

Note: *Be sure to use the correct SMB connectors (50Ω or 75Ω).*

- 1 Be sure to read “Plug-in Module Test Considerations” on page 97.
- 2 Prepare the module by connecting an SMB short to CH10, CH11, CH12, and CH13. Connect the COM1 terminal to the DMM. Be sure to use the correct SMB connectors for the module.
- 3 Install the module in slot 100.
- 4 Close Channel 11.
- 5 Measure the resistance on the DMM.
- 6 Repeat steps 4 and 5 for Channels 12, 13, and 14.
- 7 Repeat steps 2, 3, 4, 5, and 6 for the channels connected to COM2.

Note: *In general, a new relay should have a contact resistance of less than 0.5Ω. Relays with contact resistance in excess of 1Ω should be replaced.*

Relay Verification**(Optional) 34908A Relay Contact Resistance Verification**

This optional procedure uses an external DMM to make 4-wire ohms measurements across the relay contacts on the 34908A. Note that when measuring the resistance of the contacts of the channels relays, the test also includes the Bank Switch.

Note: Be sure to read “Plug-in Module Test Considerations” on page 97.

Test 1: See the diagram on page 117 for the required connections for this test (be sure to probe the inductor at the indicated location). For this measurement, the 34908A is not installed in the 34970A/34972A. Record the 4-wire ohms measurements from the external DMM in the table below.

External DMM Ohmmeter Connections					
Test #	HI	LO	HI Sense	LO Sense	Measured Value
1	L400	J101, C12	L400	J101, C12	_____ Ohms

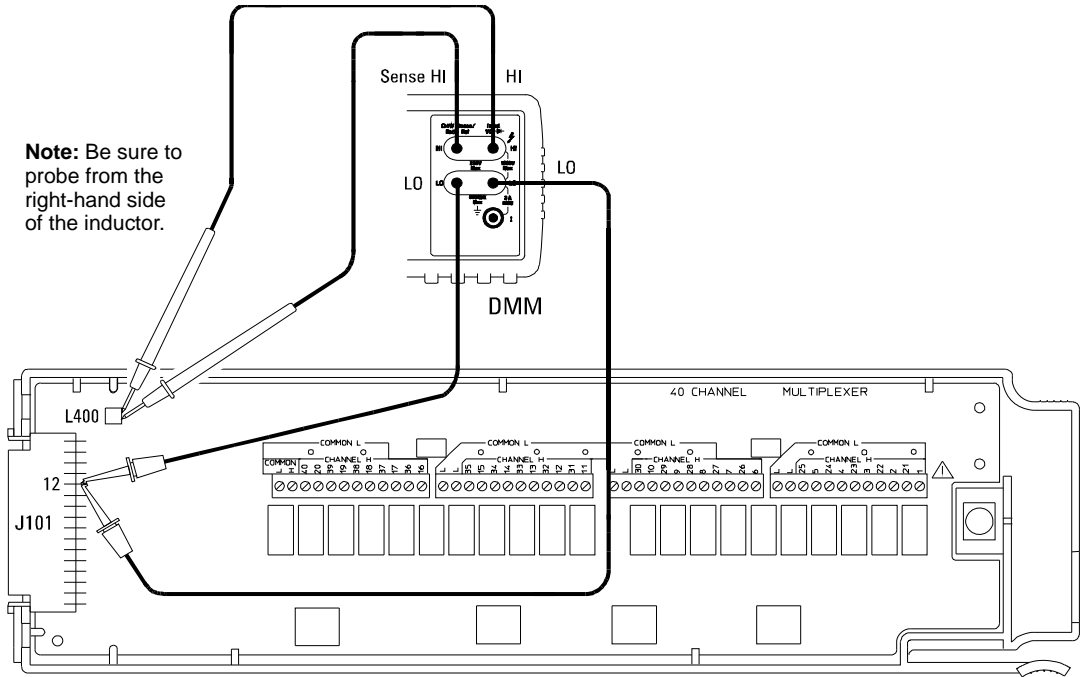

Connections for 34908A Verification Test 1

Chapter 4 Calibration Procedures

Relay Verification

Tests 2 - 3:

Make the connections to the 34908A as shown in the diagram below. Be sure to route your wiring for proper strain relief and install the module cover. Install the 34908A in slot 200 of the 34970A/34972A. Open all channels on the module by performing a Factory Reset (press **Sto/Rcl** and select “Recall State”; press **Sto/Rcl** again and select “Factory Reset”). Configure Channel 01 as follows: DC volts, 10 volt range, and 5½ digits.

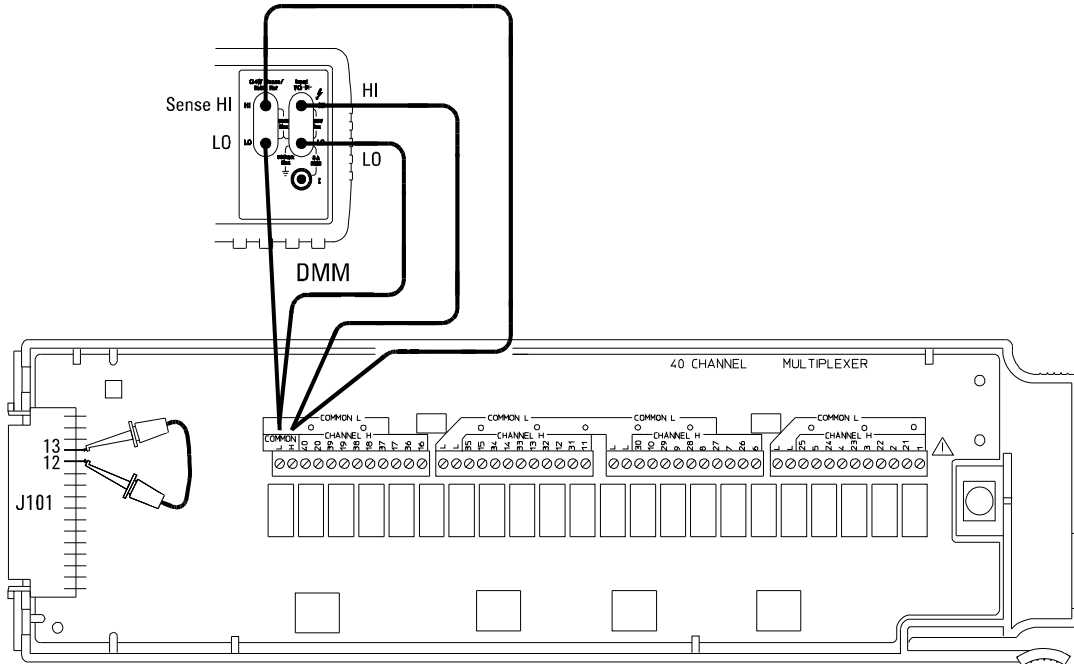

Connections for 34908A Verification Tests 2 and 3

Enable reading monitoring by pressing **Mon** on the selected channel (or use the ROUTe:MON command). Record the 4-wire ohms measurements from the external DMM in the following table.

External DMM Ohmmeter Connections								
Test #	Channel Configured	HI	LO	HI Sense	LO Sense	Measured Value	Test Limit	Relay Measured
2	Ch 01	H Com	L Com	H Com	L Com	_____ Ohms	—	—
3	Subtract (Test 2 - Test 1)					_____ Ohms	2.00Ω	K421

Tests 4 - 43:

Make the connections to the 34908A as shown in the diagram below. Connect copper shorts between all channels as shown. Be sure to route your wiring for proper strain relief and install the module cover. Install the 34908A in slot 200 of the 34970A/34972A.

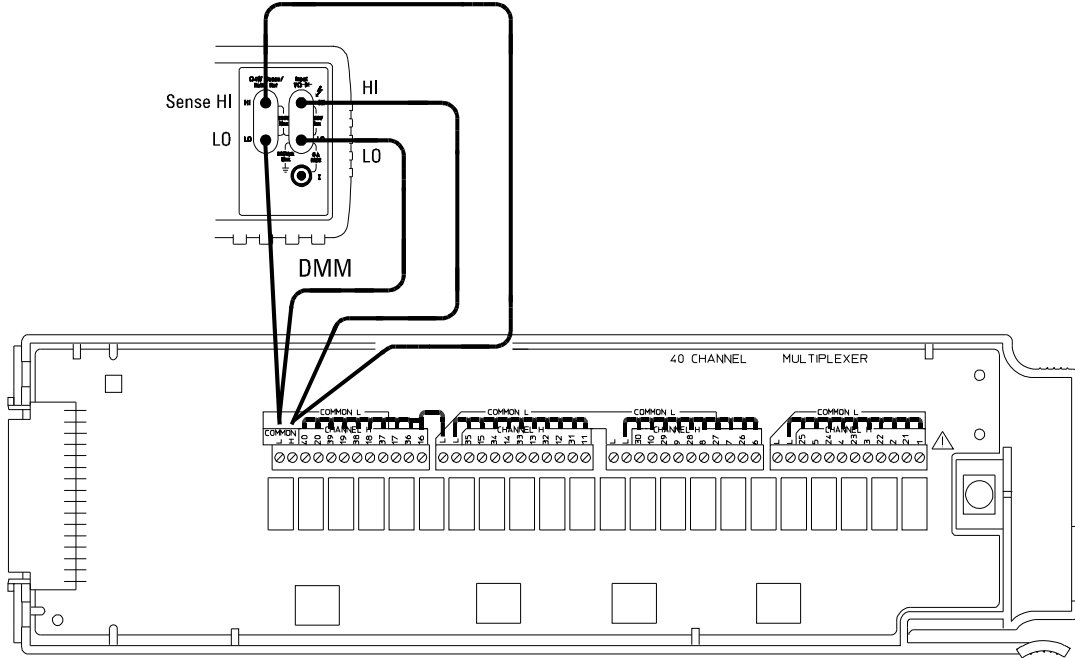

Connections for 34908A Verification Tests 4 through 43

For each test shown in the table starting on the next page, close *only* the channels shown in the “Channels Closed” column (closing one channel will open the previously closed channel). Record the 4-wire ohms measurements from the external DMM in the table.

Chapter 4 Calibration Procedures
Relay Verification

		External DMM Ohmmeter Connections						
Test #	Channel Closed*	HI	LO	HI Sense	LO Sense	Measured Value	Test Limit	Relay Measured
4	Ch 1	H Com	L Com	H Com	L Com	_____ Ohms	2.00Ω	K401, K422
5	Ch 2	H Com	L Com	H Com	L Com	_____ Ohms	2.00Ω	K402, K422
6	Ch 3	H Com	L Com	H Com	L Com	_____ Ohms	2.00Ω	K403, K422
7	Ch 4	H Com	L Com	H Com	L Com	_____ Ohms	2.00Ω	K404, K422
8	Ch 5	H Com	L Com	H Com	L Com	_____ Ohms	2.00Ω	K405, K422
9	Ch 6	H Com	L Com	H Com	L Com	_____ Ohms	2.00Ω	K406, K422
10	Ch 7	H Com	L Com	H Com	L Com	_____ Ohms	2.00Ω	K407, K422
11	Ch 8	H Com	L Com	H Com	L Com	_____ Ohms	2.00Ω	K408, K422
12	Ch 9	H Com	L Com	H Com	L Com	_____ Ohms	2.00Ω	K409, K422
13	Ch 10	H Com	L Com	H Com	L Com	_____ Ohms	2.00Ω	K410, K422
14	Ch 11	H Com	L Com	H Com	L Com	_____ Ohms	2.00Ω	K411, K422
15	Ch 12	H Com	L Com	H Com	L Com	_____ Ohms	2.00Ω	K412, K422
16	Ch 13	H Com	L Com	H Com	L Com	_____ Ohms	2.00Ω	K413, K422
17	Ch 14	H Com	L Com	H Com	L Com	_____ Ohms	2.00Ω	K414, K422
18	Ch 15	H Com	L Com	H Com	L Com	_____ Ohms	2.00Ω	K415, K422
19	Ch 16	H Com	L Com	H Com	L Com	_____ Ohms	2.00Ω	K416, K422
20	Ch 17	H Com	L Com	H Com	L Com	_____ Ohms	2.00Ω	K417, K422
21	Ch 18	H Com	L Com	H Com	L Com	_____ Ohms	2.00Ω	K418, K422
22	Ch 19	H Com	L Com	H Com	L Com	_____ Ohms	2.00Ω	K419, K422
23	Ch 20	H Com	L Com	H Com	L Com	_____ Ohms	2.00Ω	K420, K422

*Only the channel currently under test should be closed at one time. All other channels should be open.

Continued on next page...

...Continued from previous page

Test #	Channel Closed*	External DMM Ohmmeter Connections				Measured Value	Test Limit	Relay Measured
		HI	LO	HI Sense	LO Sense			
24	Ch 21	H Com	L Com	H Com	L Com	_____ Ohms	2.00Ω	K401, K422
25	Ch 22	H Com	L Com	H Com	L Com	_____ Ohms	2.00Ω	K402, K422
26	Ch 23	H Com	L Com	H Com	L Com	_____ Ohms	2.00Ω	K403, K422
27	Ch 24	H Com	L Com	H Com	L Com	_____ Ohms	2.00Ω	K404, K422
28	Ch 25	H Com	L Com	H Com	L Com	_____ Ohms	2.00Ω	K405, K422
29	Ch 26	H Com	L Com	H Com	L Com	_____ Ohms	2.00Ω	K406, K422
30	Ch 27	H Com	L Com	H Com	L Com	_____ Ohms	2.00Ω	K407, K422
31	Ch 28	H Com	L Com	H Com	L Com	_____ Ohms	2.00Ω	K408, K422
32	Ch 29	H Com	L Com	H Com	L Com	_____ Ohms	2.00Ω	K409, K422
33	Ch 30	H Com	L Com	H Com	L Com	_____ Ohms	2.00Ω	K410, K422
34	Ch 31	H Com	L Com	H Com	L Com	_____ Ohms	2.00Ω	K411, K422
35	Ch 32	H Com	L Com	H Com	L Com	_____ Ohms	2.00Ω	K412, K422
36	Ch 33	H Com	L Com	H Com	L Com	_____ Ohms	2.00Ω	K413, K422
37	Ch 34	H Com	L Com	H Com	L Com	_____ Ohms	2.00Ω	K414, K422
38	Ch 35	H Com	L Com	H Com	L Com	_____ Ohms	2.00Ω	K415, K422
39	Ch 36	H Com	L Com	H Com	L Com	_____ Ohms	2.00Ω	K416, K422
40	Ch 37	H Com	L Com	H Com	L Com	_____ Ohms	2.00Ω	K417, K422
41	Ch 38	H Com	L Com	H Com	L Com	_____ Ohms	2.00Ω	K418, K422
42	Ch 39	H Com	L Com	H Com	L Com	_____ Ohms	2.00Ω	K419, K422
43	Ch 40	H Com	L Com	H Com	L Com	_____ Ohms	2.00Ω	K420, K422

*Only the channel currently under test should be closed at one time. All other channels should be open.

Note: If the first 20 or last 20 relays have high resistance values, it is likely that relay K422 is bad.

Thermocouple Reference Junction (Optional)

Note: *You should perform these verification and adjustments if you are using the modules for thermocouple measurements.*

To make a thermocouple measurement a known reference junction temperature measurement must be made. The reference junction temperature is measured by two solid state temperature sensors in the input connection area on the module. The adjustments store calibration constants used to correct the measurements from the temperature sensors.

Thermocouple measurements are supported by only the 34901A, 34902A and 34908A.

Thermocouple Reference Junction Verification

- 1 Read “Plug-in Module Test Considerations” on page 97.
- 2 Connect a calibrated thermocouple with an accuracy of 0.1 °C or better to one of the following channels:
 - For the 34901A: Channel 10
 - For the 34902A: Channel 8
 - For the 34908A: Channel 10
- 3 Install the module in slot 100.
- 4 Place the J Type calibrated thermocouple at a known temperature (ice bath or calibrator).
- 5 Select Channel 110 (or 108). Configure the channel as follows:
 - TEMPERATURE
 - THERMOCOUPLE
 - J TYPE
 - INTEG 10 PLC (*Advanced* menu)
 - INTERNAL REF (*Advanced* menu)

Before executing each test, you must press to enable reading monitoring on the selected channel (or use the ROUTE:MON command from the remote interface).
- 6 Subtract the thermocouple error from the displayed temperature. Verify the result is within ± 1.0 °C of the known temperature (set in step 4).

Thermocouple Reference Junction Adjustments

These adjustments are plug-in module specific and only affect thermocouple measurements. The calibration constants created by these adjustments are stored in non-volatile memory *on the plug-in module*.

- 1 Connect a 10 kΩ (YSI 44031) thermistor to each of the following channels (a kit of five thermistors is available as Agilent part number 34308A):

For the 34901A Channels 6 and 17

For the 34902A Channels 6 and 11

For the 34908A Channels 6 and 16

Keep the thermistor leads as short as possible. Locate the thermistor as near to the input connectors as possible.

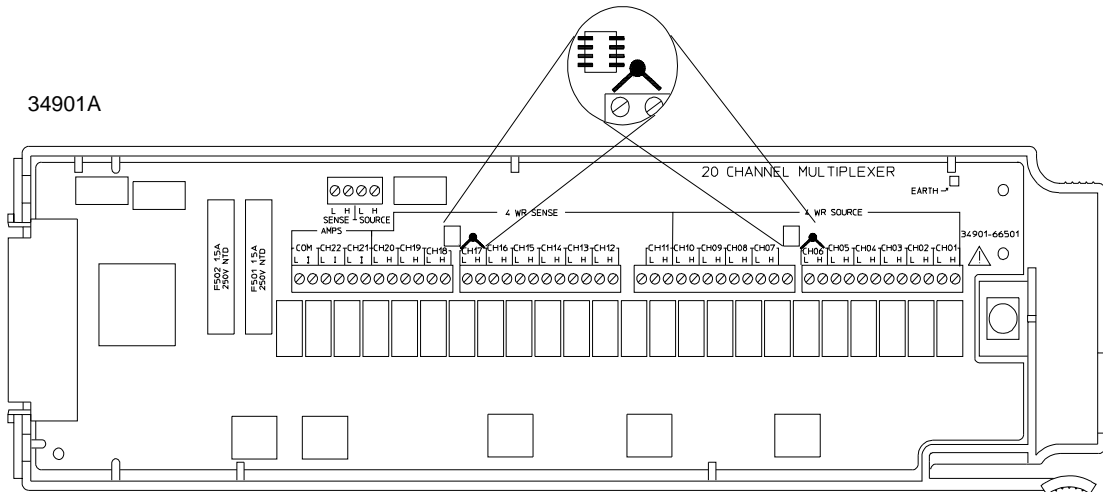

- 2 Install the plug-in module in the mainframe in slot 200. Apply power and allow a 2 hour warm-up.
- 3 Set 10 kΩ thermistor measurements on Channels 206 and 217 (or 206 and 211). Before executing each test, you must press **Mon** to enable reading monitoring on the selected channel (or use the ROUTE:MON command from the remote interface).
- 4 Press **Shift View** to enter the calibration menu. Press **View** again to begin the adjustment procedure.
- 5 Verify the adjustment (*see page 122*).

34907A Analog Output

Analog Output Verification Test

This procedure is used to check the calibration of the analog outputs on the 34907A Multifunction Module. Install the module in slot 200. Verification checks are performed only for those output values with unique calibration constants.

- 1 Make connections to analog output channels as shown below.

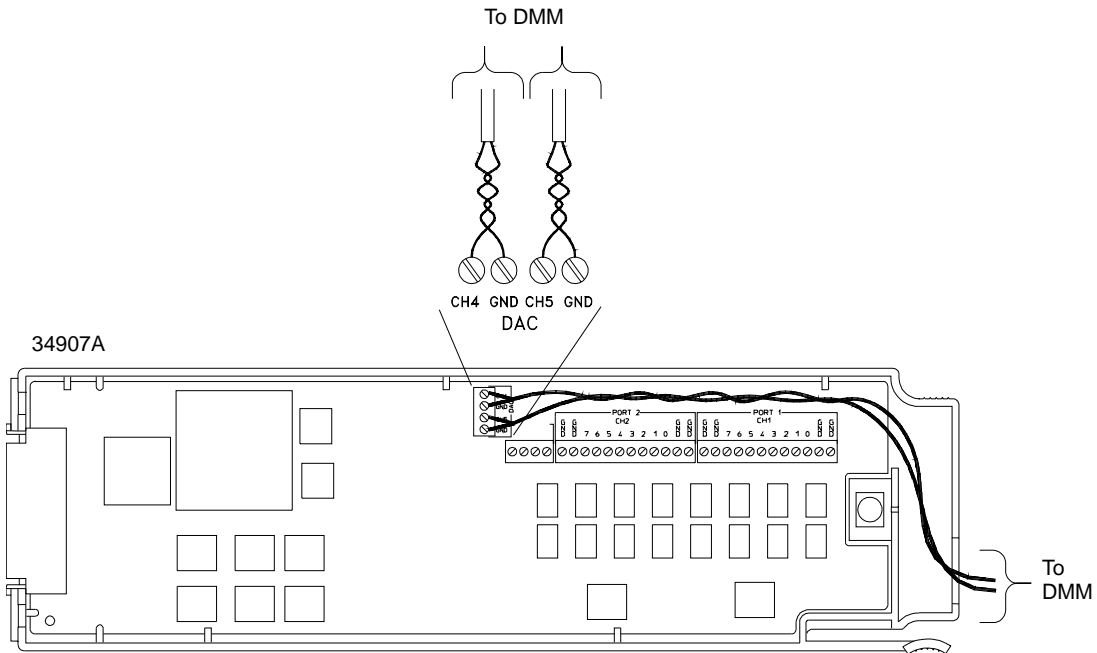













- 2 For each analog output, set each output value in the table below. Compare measurement results to the appropriate test limits shown in the table.

DAC Output	Quick Check	Measured Output	Error from Nominal 1 year
0.000 V	Q	0.000 V	± 20 mV
10.000 V		10.000 V	± 45 mV

Analog Output Adjustment

Note: Install the 34907A module in the mainframe and allow a 45 minute warm-up before performing these procedures.

This adjustment procedure sets a zero adjustment and a gain adjustment constant for each DAC output. You must perform all the adjustments on one analog output channel before adjusting the other analog output channel.

- 1 Install the module in slot 100. Select the first analog output channel (104).
- 2 Connect an external DMM to the output terminals.
- 3 Set the analog output to 00.000 V.
- 4 Press   to enter the calibration menu. Press  again to begin the adjustment procedure.
- 5 Use the knob,  and  to set the number in the display to the measured output value and press  to complete the adjustment.
- 6 Set the analog output to 10.000 V.
- 7 Press   to enter the calibration menu. Press  again to begin the adjustment procedure.
- 8 Use the knob,  and  to set the number in the display to the measured output value and press  to complete the adjustment.
- 9 Repeat steps 1 through 8 for Channel 105.
- 10 Perform the Voltage Output Verification Test on page 114 to verify the adjustment.



Theory of Operation

Theory of Operation

This chapter is organized to provide descriptions of the circuitry contained on each schematic shown in chapter 8. A block diagram overview is provided.

- System Block Diagram, *on page 129*
- Floating Logic, *on page 130*
- Memory, *on page 133*
- Earth-Referenced Logic, *on page 134*
- Power Supplies, *on page 135*
- Front Panel, *on page 137*
- Backplane, *on page 138*
- Internal DMM, *on page 139*
- Switch Modules, *on page 148*
- Multifunction Module, *on page 161*

The self-test procedures are described in chapter 6.

System Block Diagram

A simplified block diagram is shown below. Not all systems have an Internal DMM. In these systems, the internal DMM connections to the analog bus and the floating logic are left open. The major portions of each block are described in the following sections.

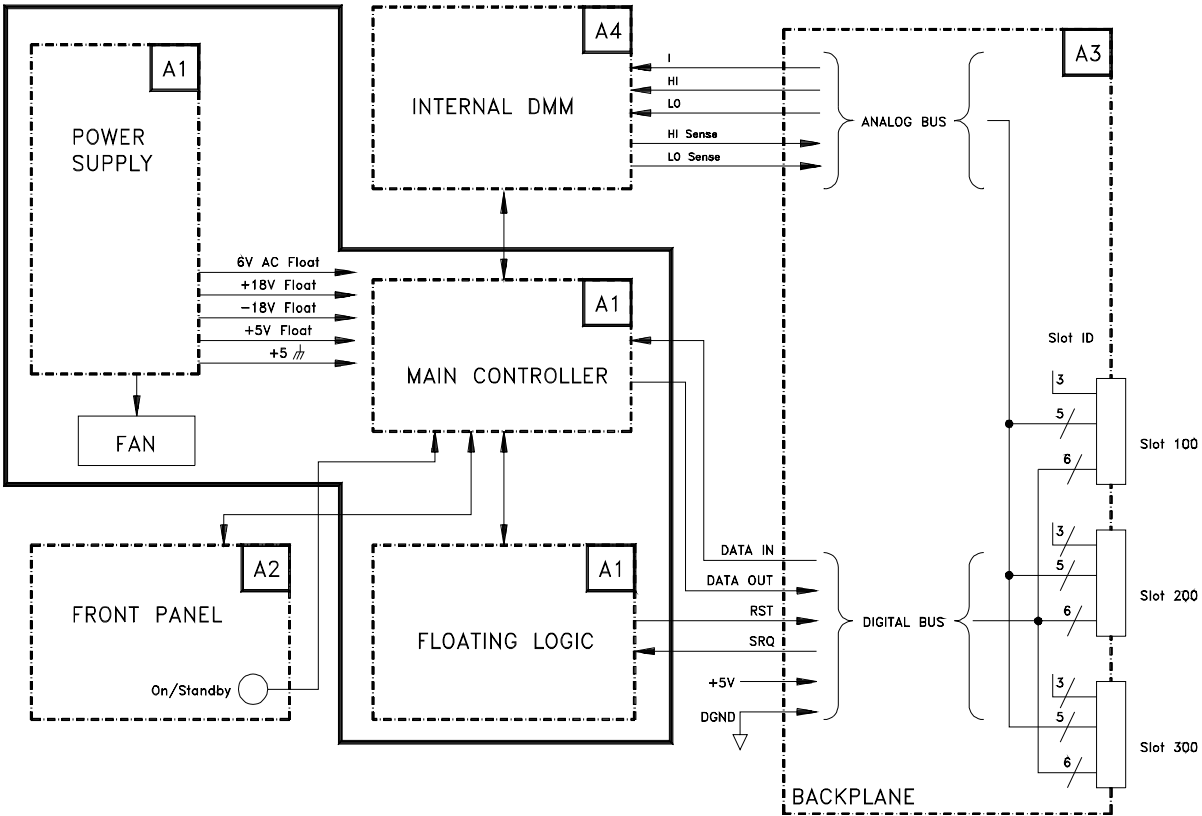

Floating Logic

Unless otherwise noted, components in this discussion are located on the A1 circuit assembly (34970-66501).

The floating common logic controls the operation of the entire instrument. All measurement control and remote interface command interpretation is performed in the main controller, U205. The front panel controller, the I/O controller, and all of the plug-in module controllers, act as slaves to U205. The floating common logic is comprised of the main controller U205, custom ASIC U209, calibration memory U201, 12 MHz clock oscillator U204, and microprocessor supervisor U104.

The microprocessor supervisor U104 performs the following functions:

- Monitors the regulated 5V floating supply and generates the reset signal for main controller U205 when the voltage drops below operating levels.
- Monitors the unregulated side of the 5V floating supply in order to generate an early warning signal (PWRFAIL) when power is lost.
- Provides automatic switch over to the battery BT101 for the +5V_NV supply when the 5V_FLT supply drops below the battery voltage.
- Blocks the main controller's write signal (WR_N) while the 5V_FLT supply is below operating level.

The main controller, U205, is a 16-bit microcontroller incorporating many built-in features:

- A 10-bit, successive approximation ADC with selectable inputs is used to convert two signals: FLASH and FRQRNG. The FLASH signal is the residual charge on the main integrating ADC output from the internal DMM assembly (A4). The FRQRNG signal (also from the internal DMM) is used to make voltage ranging decisions for frequency and period measurements.
- A pulse-width-modulation port, after filtering the 23 kHz output with R221, C224, and R259, produces DC voltages between 0V and 5V. This voltage, PREADJ, is used to adjust the precharge amplifier offset voltage in U101 on the internal DMM assembly (A4).
- A full, UART controlled, serial port is used to communicate with the I/O processor through opto-isolators U303 and U214. Data is sent in an 11-bit frame at a rate of 187.5 kbits/second. The 11-bit frame is configured for one start bit, nine data bits, and one stop bit.
- A timer is used to measure the power line frequency on LSENSE. Frequencies between 55 Hz and 66 Hz result in the use of a 60 Hz standard for the DMM integration period. All other frequencies will result in the use of a 50 Hz standard.
- A 16-bit counter counts pulses on CNT to create, along with the 8-bit counter in U209, a 24-bit counter for the internal DMM.

Floating Logic

The custom ASIC, U209, provides:

- **Memory Address mapping** – The main controller multiplexes address and data on the same bus. U209 latches the address and drives a separate memory address bus (MA(19:1)). U209 allows the main controller to access a much larger memory space than its 16-bit address bus would allow. It also partitions memory into separate data and instruction segments and a “mappable” segment that can be used for either data or instructions.
- **Communications** – U209 provides three serial communication ports. A 187.5 kbit/second, 9 data bit, UART for communicating with the isolated backplane (FLT_BPDO and FLT_BPDI_N). A duplicate, 9-bit UART to communicate with the front panel (FPDO and FPDI). And a simple, 1.5 Mbit/second, clocked shift-register to control the configuration registers on the DMM assembly (CFG_SCK, CFG_DO, and CFG_DI).
- **Real Time Clock** – U209 provides time of day and date, a periodic interrupt, and a squarewave generator. The date is based on a 100 year calendar (it accurately tracks leap years until its two digit year counter rolls over). U209 uses the battery-backed +5V_NV supply.
- **DMM support** – U209 provides conversion logic for the analog-to-digital converter and a counter for both the ADC and the frequency measurement features of the DMM. When used for the ADC, the COMP input functions both as a clocked comparator and the slope counter input. When used for frequency measurement, FREQIN is the input to the counter. In both cases, the 8-bit counter produces the lower bits of a 24-bit counter. The counter overflow signal, CNT, is counted by U205 to produce the upper 16-bits of the count. The SYNC signal produced by U205, is used to latch the count.

Device U201 is a 512 byte, ferroelectric RAM that is accessed via a serial interface. This device only contains data relevant to the A1 assembly. This data is combined with data retrieved from A4U450 to completely calibrate the internal DMM. The two devices, although on different assemblies, share the same I/O signals, CALSCK and CALDAT, that allow them to be read (and written) by U205.

Memory

Unless otherwise noted, components in this discussion are located on the A1 circuit assembly (34970-66501).

The main controller, U205, uses 512 Kbytes of ROM and 544 Kbytes of RAM. ASIC U209 provides the memory mapping that allows access to this large memory space. The memory map as seen by the main controller is as follows:

Address	Maps to
0100H thru 1FBFH	00100H thru 01FBFH in RAM for data fetches
0100H thru 1FBFH	00100H thru 01FBFH in ROM for instrument fetches
1FC0H thru 1FDFH	registers in U209
2000H thru 5FFFFH	02000H thru 05FFFFH in ROM
6000H thru 7FFFFH	06000H thru 07FFFFH in RAM for data fetches
6000H thru 7FFFFH	06000H thru 07FFFFH in ROM for instrument fetches
8000H thru FFFFH	any selected 32 Kbyte page of ROM or RAM

The memory is organized with a 16-bit data bus (AD(15:0)) and a 19-bit address bus (MA(19:1)). The memory address is produced by U209 latching the address present on AD(15:0) when U205 asserts ALE_FLT. Reads of memory are always 16-bits wide (there is a single RD_N signal). Writes, however, can be byte-wide and therefore U209 produces both a high-byte write strobe, MWRH_N, and a low-byte write strobe, MWRL_N. These write signals are based on the latched 0-bit of the address and the BHE_N signal produced by the main controller, U205.

The ROM memory consists of a single, 256Kx16 device, U401. The RAM memory consists of five devices: U402, U403, U404, U405, and U410. A uniform, 256Kx16, memory block is formed by the four 128Kx8 devices, U402 through U405. A separate, 32Kx8 block is formed by U410 and is available through special programming of U209.

Earth-Referenced Logic

Unless otherwise noted, components in this discussion are located on the A1 circuit assembly (34970-66501).

The earth-referenced logic circuits provide all rear panel input/output capability. Microprocessor U305 handles GPIB (IEEE-488) control through bus interface chip U309 and bus receiver/driver chips U310 and U311.

The RS-232 interface is controlled by U305 through U307. RS-232 transceiver chip U308 provides the required level shifting to approximate ± 9 volt logic levels through on-chip charge-pump power supplies using capacitors C317 through C320. Communication between the earth referenced logic interface circuits and the floating measurement logic is accomplished through an optically-isolated bi-directional serial interface. Isolator U214 couples data from U305 to microprocessor U205. Isolator U303 couples data from U305 to microprocessor U205.

U305 also:

- Controls power to the backplane as well as all rear panel interfaces (GPIB, RS-232, Alarms, External Triggers). Backplane power is turned on or off based upon commands received from U205.
- Drives the backplane reset signal (BPRST) based upon commands from U205.
- Monitors the backplane service request (BPSRQ_N) and reports to U205 when it is asserted.

U306B, U306C, U306D, and U306E drive the alarm outputs. The alarm is a low true signal at the sub miniature D connector on the rear panel. U306F drives the channel closed output signal.

The external trigger input is buffered by U304C and U304D.

Power Supplies

Unless otherwise noted, components in this discussion are located on the A1 circuit assembly (34970-66501).

The instrument uses two types of power supplies: *floating supplies* and *earth referenced supplies*. The floating supply outputs are ± 18 VDC, +5 VDC, and a 6 Vrms center tapped filament supply for the vacuum fluorescent display. The earth referenced and backplane circuits are powered from a single +5 VDC supply.

The AC mains are connected by module P1. This module includes the functions of mains connection and line voltage selection (100/120/ 220/ 240). The internal DMM automatically configures for the applied line frequency by counting the frequency of the output of clamp circuit CR106, R102, C103 (LSENSE).

The +5 volt floating supply is produced by bridge rectifier CR105, filter capacitor C104, and regulator U103. The output of CR105 is sensed by U104 and compared to the voltage from battery BT101. U104 turns on the +5 V floating supply through Q120. If the output of CR105 falls below 6.8 V, U104 provides a PWRFAIL signal to the main processor. At initial power on, U104 resets the main processor with the FLT_RST line. This supply powers all floating logic. The internal DMM relay drive circuits are also powered from this supply.

The floating ± 18 volt supplies are produced by bridge rectifier CR109, filter capacitors C107 and C109, and regulators U105 and U106. These supplies are used to power all measuring circuits. In addition, the vacuum fluorescent display is driven from the ± 18 volt supplies.

A separate winding of T1 provides a center tapped 6 Vrms filament supply for the display. Q110A and Q110B turn on and off the filament supply in response to the FILPWR signal from the main controller through U107A.

Power Supplies

The 5 volt earth referenced supply (+5V_ER) is produced by rectifier CR101, CR102, CR103, CR104, and regulator U101. This supply is earth referenced by the screw which mounts the PC board to the instrument chassis.

The unswitched +5V_ER supplies U305, U303, U320, and U302. The rear-panel interfaces (GPIB, RS-232, Alarms, and external triggers) are powered from the switched +5V_BP supply to ensure that when power is turned off no voltages are present at the interfaces.

The +5V_ER supply is switched by Q101A and Q101B to create the +5V_BP (backplane) and fan power supplies.

Undervoltage sensor U102 provides the earth reference controller reset at initial power on.

Front Panel

Unless otherwise noted, components in this discussion are located on the A2 circuit assembly (34970-66502).

The front-panel circuits consist of vacuum fluorescent display control, display high voltage drivers, and keyboard scanning. Communication between the front panel and floating logic circuits is accomplished through a 2-wire bi-directional serial interface. The front-panel logic operates from -13 volts (logic 1) and -18 volts (logic 0). The two serial communication signals are level shifted by comparator U6 from the floating logic 0 V to 5 V levels to the -18 V to -13 V levels present on the front panel assembly. The front panel logic high supply (-13 volts) is produced from the -18 volt supply by voltage regulator U7.

Display anode and grid voltages are +18 volts for an on segment and -18 volts for an off segment. The -11 V cathode bias for the display is provided by the main pc boards filament winding center tap bias circuit A1CR108, A1R106, and A1C106.

Keyboard scanning is accomplished through a conventional scanned row-column key matrix. Keys are scanned by outputting data at microprocessor U1 port pins P0.0 through P0.4 to poll each key column for a key press. Column read-back data are read by the microprocessor at port pins P2.0 through P2.3 for decoding and communication to the floating logic circuits. Rotary knob quadrature inputs are read directly by the microprocessor port pins P2.6 and P2.7.

The standby power switch, S19, provides a low true signal to main controller A1U205. In turn, A1U205 takes actions that either place the instrument in the “standby mode” or “on” mode. In “standby”, both the filament supply to the front panel and the +5V_BP supply to the backplane, rear panel interfaces, and fan are turned off.

Backplane

Backplane

Unless otherwise noted, components in this discussion are located on the A3 circuit assembly (34970-66503).

The backplane contains three connectors, P101, P102, and P103 for connection to the plug-in modules. The parallel lines in these connectors are divided into two groups to form the analog bus and digital bus.

Analog Bus

The analog bus connects the signals from the plug-in modules to the Internal DMM. There are five lines in the analog bus, HI, LO, OHMS_HI, OHMS_LO, and AMPS. The HI and LO lines are protected from overvoltages by E101, E102, RV101, RV102, R101, R160, L101, L102, and C109.

P105 makes the analog bus connection to the internal DMM.

Digital Bus

The digital bus uses 10 lines for communication and control. P104 makes the digital bus connection to the earth referenced logic and floating logic.

Signal	P101, P102, P103 Pins	Comments
Slot ID	A6, A7, A8	Unique binary code for each slot.
DATA_IN	B6	Serial module data from the floating logic.
DATA_OUT	C6	Serial module data to the floating logic.
DGND	A5, B5, B7, C5, C7	Earth referenced digital ground.
+5 V	A3, B3, C3	Earth referenced module power supply.
Earth Ground	A1, B1, C1	Earth referenced zap return ground.
RST	B8	Module reset from the earth referenced logic.
SRQ	C8	Module service request to the earth referenced logic.

Internal DMM

DMM Block Diagram

A portion of the internal DMM block diagram is shown below.

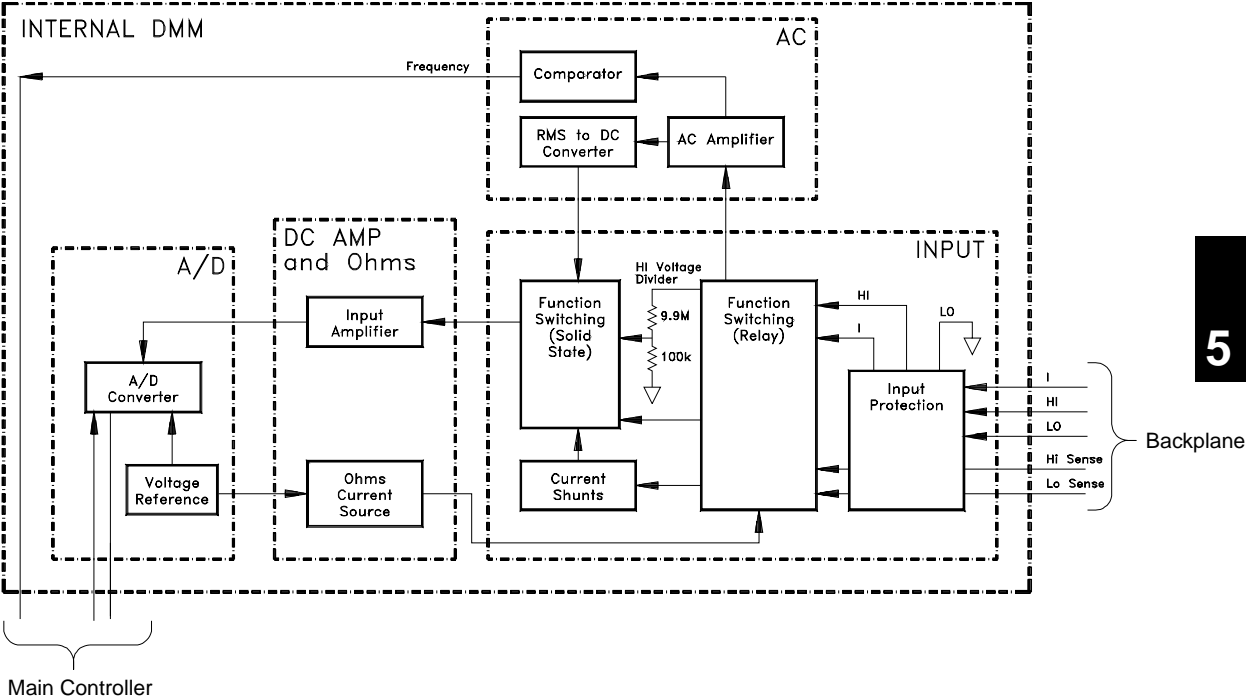

Internal DMM**Input**

Unless otherwise noted, components in this discussion are located on the A4 circuit assembly (34970-66504).

The purpose of the Input section is to connect the **Input HI** terminal to the various measuring functions. This is accomplished through K102, K103, and K104. Additionally, connections are made for the 4-wire ohms **HI Sense** and **LO Sense** inputs. Shunt selection (ranging) and voltage sensing are also performed for the current function. The table below shows the state of each relay for each measuring function. All relay coils are driven from U150.

Functional	K102	K103	K104	Sense at:
0.1 V - 10 VDC	Set	Set	Set ^[1]	U101-5
100 V - 300 VDC	Set	Reset	Set	U102-12
2-Wire Ohms	Reset	Set	Reset ^[2]	U101-5 ^[3]
4-Wire Ohms	Reset	Set	Reset ^[2]	
AC Voltage	Set	Reset	Reset	AC_IN
Frequency/Period	Set	Reset	Reset	AC_IN
3 A, 1A DCI	Reset	Reset	Reset	U101-10
100 mA, 10 mA DCI	Set	Reset	Reset	U101-10
1A AC I	Reset	Reset	Set	AC_IN

[1] K104 will be reset when input resistance is selected to >10,000 M Ω through the menu.

[2] K104 will be set for the 100 M Ω range.

[3] Configurations shown are for the current source output (HI) terminal. The measurement sense is accomplished through the Sense HI / Sense LO terminals.

Input Amplifier

Unless otherwise noted, components in this discussion are located on the A4 circuit assembly (34970-66504).

The DC Amplifier circuit is used by every measuring function except frequency and period. Analog switch U101B selects various input signals for measurement by the ADC. Switch U101B has three sources which can be dynamically selected: *measure customer input* (MC), *measure zero input* (MZ), and *precharge* (PRE). The MC state is the actual input measurement. The MZ state measures internal offset voltages which are also present in the MC measurement. The final measurement result is computed from MC–MZ. The PRE state is used to “precharge” internal capacitances to reduce charge injection to the input terminal from the dynamic switching of MC and MZ. Autozero off disables the dynamic switching of the amplifier input. However, a new MZ value is automatically taken whenever a new function or range is selected, even if autozero is turned off.

In the DC voltage function, ranging is accomplished through both input relay switching (K102–K104) and solid state switching (U101). As a result, the input to the ADC has the same nominal 10 V value for a full scale input on each range. The DC input amplifier is comprised of source follower dual FET U104, amplifier U106, and associated bias circuitry. The feedback resistors U102C and switches U101C select non-inverting amplifier gains of x1, x10, and x100 for the DC input amplifier circuit. Amplifier output ADIN drives the DC input to the a-to-d converter for all measuring functions.

DCV Range	U102 Divider	U101 Input	Amplifier Gain	ADC Input
100 mV		Pin 5	x100	10 V
1 V		Pin 5	x10	10 V
10 V		Pin 5	x1	10 V
100 V	1/100	Pin 8	x10	10 V
1000V	1/100	Pin 8	x1	10 V

Internal DMM

In the DC current function, a current is applied between the Input I and **LO** terminals. Ranging is accomplished by relay K102 and amplifier gain switching in U101. Since a known resistor (the shunt resistor) is connected between these terminals, a voltage proportional to the unknown current is generated. The voltage sensed at R121 is measured by the multimeter's DC circuitry. The table below illustrates the DC current measuring function configurations.

DCI Range	Shunt Resistor	U101-10 Input	Amplifier Gain	ADC Input
1A	0.1 Ω	100 mV	x100	10 V
100 mA	5.1 Ω	510 mV	x10	5.1 V
10 mA	5.1 Ω	51 mV	x100	5.1 V

Resistance measurements are made by applying a known current through an unknown resistance. The resulting voltage drop across the unknown resistance is then measured by the multimeter's DC circuitry. The 100 M Ω range is measured using the known internal 10 M Ω resistance (U102A) in parallel with the unknown input resistance while applying the 500 nA current source. The result is computed from the measured data. The internal 10 M Ω resistance is determined whenever a zero calibration is performed.

In the 2-wire ohms function, the voltage drop is measured across the **Input HI** and **Input LO** terminals. In the 4-wire ohms function, the voltage is measured across the **HI Sense** and **LO Sense** terminals. Lead resistances in series with the current source (**Input HI-LO**) are not part of the final measurement. However, they do reduce the available current source compliance voltage for the resistor under test. The ohms current source will become non-linear when the compliance voltage limit is exceeded. The full scale voltage developed across the unknown resistor and the DC amplifier gain for each resistance range are tabulated below.

Ohms Range	Voltage Across R	Amplifier Gain	ADC Input
100 Ω	100 mV	x100	10 V
1 k Ω to 100 k Ω	1 V	x10	10 V
1 M Ω	5 V	x1	5 V
10 M Ω	5 V	x1	5 V
100 M Ω	4.5 V	x1	4.5 V

Ohms Current Source

Unless otherwise noted, components in this discussion are located on the A4 circuit assembly (34970-66504).

The ohms current source flows from the **Input HI** terminal to the **Input LO** terminal for both the 2-wire and 4-wire ohms functions. Each current value is generated by forcing a stable, precise voltage across a stable resistance. The value of the current becomes part of the range gain constant stored during calibration.

The +7 V reference voltage is used to generate a stable reference current with U201A. R201 and R202 are the resistance references for the current sources as shown in the table below. The IREF current is used to produce a precise voltage drop across the 28.57 k Ω resistor in U102D-4. The IREF generated using R202 produces an approximate 5 V drop across the 28.57 k Ω resistor. The IREF generated using R201 produces an approximate 0.5 V drop. This voltage is used to force a reference voltage across the selected current source range resistor (5 k Ω , 50 k Ω , 500 k Ω , 1M Ω) by U201B. The resulting precision current flows through JFET Q202 and protection circuit Q203 to Q211, and CR202 to relay K102 where it is switched to the **Input HI** terminal for ohms measurements.

The protection circuits are designed to protect the ohms current source from inadvertently applied voltages in excess of ± 1000 V. Protection from large positive voltages is provided by the reverse breakdown voltage of CR202. Protection from large negative voltages is provided by the sum of the collector to base breakdown voltages of Q203, Q205, Q207, and Q209. Bias for these transistors is provided by Q211 and R203 to R206 while negative over voltages are applied.

Ohms Range	Current	Open Circuit Voltage	Compliance Limit	Reference	Isource R U102D
100 Ω	1 ma	9 V	2.5 V	R202	5 k Ω
1 k Ω	1 mA	9 V	2.5 V	R202	5 k Ω
10 k Ω	100 μ A	9 V	4 V	R202	50 k Ω
100 k Ω	10 μ A	9 V	4V	R202	500 k Ω
1 M Ω	5 μ A	9 V	8 V	R202	1 M Ω
10 M Ω	500 nA	14 V	10 V	R201	1 M Ω
100 M Ω ^[1]	500 nA ^[1]	5 V		R201	1 M Ω

[1] Measured in parallel with the internal 10 M Ω resistor.

Internal DMM**AC Circuit**

Unless otherwise noted, components in this discussion are located on the A4 circuit assembly (34970-66504).

The multimeter uses a true RMS ac-to-dc converter to measure AC voltages and currents. The ac-to-dc converter changes the input AC voltage to a DC voltage. All voltage ranging is performed in the AC circuit so that the input to the multimeter's DC circuitry (AC_OUT) is nominally 2 VDC for a full scale AC input. The DC amplifier is always configured for x1 gain in AC functions (voltage, current, frequency, and period). Relay K104 connects the AC circuit to either the **Input HI** terminal or to R121, the current function voltage sense point. Note that the input to the AC circuit may contain a DC bias from the applied AC signal.

Input coupling capacitor C301 blocks the DC portion of the input signal. Only the AC component of the input signal is measured by the multimeter. The AC circuit voltage ranging comprises two gain stages U301 and U305/U312. The voltage gains for each stage are tabulated below.

Function	Range	Shunt Resistor	1st Stage	2nd Stage	ADC Input
ACV, Freq, or Period	100 mV		x0.2	x100	2 VDC
	1 V		x0.2	x10	2 VDC
	10 V		x0.2	x1	2 VDC
	100 V		x0.002	x10	2 VDC
	300 V		x0.002	x1	1.4 VDC
ACI	10 mA	5.1Ω	x0.2	x100	0.2 VDC
	100 mA	0.1Ω	x0.2	x100	1 VDC
	1 A	0.1Ω	x0.2	x100	2VDC

The 1st stage is a compensated attenuator implementing a gain of x0.2 or x0.002 as selected by U304A and U304D. Each voltage range has a unique 50 kHz frequency response correction produced by a programmable variable capacitor connected across R304.

The programmable capacitance is implemented by varying the signal level across a compensating capacitor. In the x0.2 configuration, low frequency gain is set by R301, R302, and R304. The variable gain element U302/U303 essentially varies the value of C306 from 0 to 1 times its value in 256 steps. The exact gain constant is determined during the 50 kHz AC voltage range calibration procedure. In the x0.002 configuration, low frequency gain is set by R301, R302, and R303. The variable gain element U302/U303 essentially varies the value of C305 plus C306 from 0 to 1 times their value in 256 steps. The exact gain constant is determined during the 50 kHz AC voltage range calibration procedure.

The second stage is made up of two amplifiers (U305 and U312) each configured for a fixed gain of x10. Overall 2nd stage gains of x1, x10, and x100 are produced by routing the 1st stage output either around, or through one or both amplifiers as shown in the table below.

2nd State Gain	U306A	U306B	U306C	U306D	U304C
x1	ON	OFF	OFF	OFF	OFF
x10	OFF	ON	OFF	ON	OFF
x100	OFF	ON	ON	OFF	ON

5

The output of the 2nd stage is connected to the rms-to-dc converter stage. Any residual DC offset from the amplifier stages is blocked by capacitor C316. Buffer U307 drives the input to the rms-to-dc converter as well as the frequency comparator (U310A) input. The rms-to-dc converter has two selectable averaging filters (C318 and C318 plus C321) for the analog computer circuit of U308. The two analog averaging filters together with digital filters running in the main CPU implement the three selectable AC filters: slow, medium, and fast. The faster analog filter (using C318) is used for all AC V, AC I, and frequency or period autoranging. The slower analog filter is used only with the slow and medium AC filter choices.

In frequency or period measurements, U310A generates a logic signal (FREQIN) for every input zero crossing. The AC sections FREQRNG DC output is measured directly by the main CPU's 10-bit ADC during frequency or period measurements. This lower resolution measurement is sufficient to perform voltage ranging decisions for these functions. The frequency comparator output is disabled during AC voltage and current measurements by U310B forcing U310A's input to -15 volts.

A-to-D Converter

Unless otherwise noted, components in this discussion are located on the A4 circuit assembly (34970-66504).

The analog-to-digital converter (ADC) is used to change DC voltages into digital information (schematic shown on page 9-12). The circuitry consists of an integrator amplifier (U402 and U420), current steering switch U411, resistor network U102E, voltage reference U403, ADC controller U209, and residue ADC U205.

The ADC method used is called *multislope III*. It is based on patented Agilent ADC technology. Multislope III is a charge balancing continuously integrating analog-to-digital converter. The ADC charge balancing algorithm is always running, even when the multimeter is not triggered. The input voltage continuously forces charge onto the integrator capacitors C400 and C401 through U102E–R16.

Switches U411A and U411B steer fixed positive or negative reference currents onto the integrator capacitor to cancel, or balance, the accumulated input charge. The level shifted (R403 and R406) output of the integrator is checked every 2.66 μs by the A1U209 COMP input. Logic state machines in A1U209 control the U411 current steering to continuously seek an approximate 2.5 V level on the integrator amplifier output, FLASH. If the ADC input voltage ADIN is between ± 15 V, the integrator output (FLASH) will remain within the 0 V to 5 V range of the A1U205 on-chip ADC. An input greater than +15 V may cause the integrator output (U402–6) to saturate at about -18 V. An input less than -15 V may cause U402 to saturate with an output of about +18 V. The A1U205 ADC input (FLASH) is clamped to 0 V or 5 V by R405 and CR403 to protect A1U205.

The integrator amplifier is formed by U402 and U420. Resistors R420 and R421 affect the amplifier stability. Amplifier oscillation may occur if their values are incorrect. Amplifier U420 improves the offset voltage characteristics of integrator amplifier U402.

Each analog-to-digital conversion begins when the multimeter is triggered. The ADC starts by clearing the integrator slope count in A1U209. At the end of the integration period, the slope count is latched. The slope count provides the most significant bits of the input voltage conversion. The least significant bits are converted by the on-chip ADC of CPU A1U205.

The instrument precision voltage reference is U403. Resistor R409 provides a stable bias current for the reference zener diode. R408 and CR404 provide a bias to assure that the reference zener biases to +7 V during power up. IC U400A amplifies the voltage reference to +10 V while amplifier U401A inverts the +10 V reference to -10 V. The reference voltages force precision slope currents for the integrating ADC through U102E-R17, R18.

Switch Modules

In general, all the switch modules share a common module control circuitry. This circuitry is described below. Each module is described in further detail on the following pages.

Switch Module	Name	Page
34901A	20 Channel MUX with T/C Compensation	152
34902A	16 Channel Reed MUX with T/C Compensation	154
34903A	20 Channel Actuator	156
34904A	4 X 8 Matrix Switch	157
34905A	50 Ω Dual 4:1 VHF MUX	158
34906A	75 Ω Dual 4:1 VHF MUX	158
34908A	40 Channel Single-Ended MUX with T/C Compensation	159

Switch Module Control

A simplified block diagram of a typical module controller is shown below.

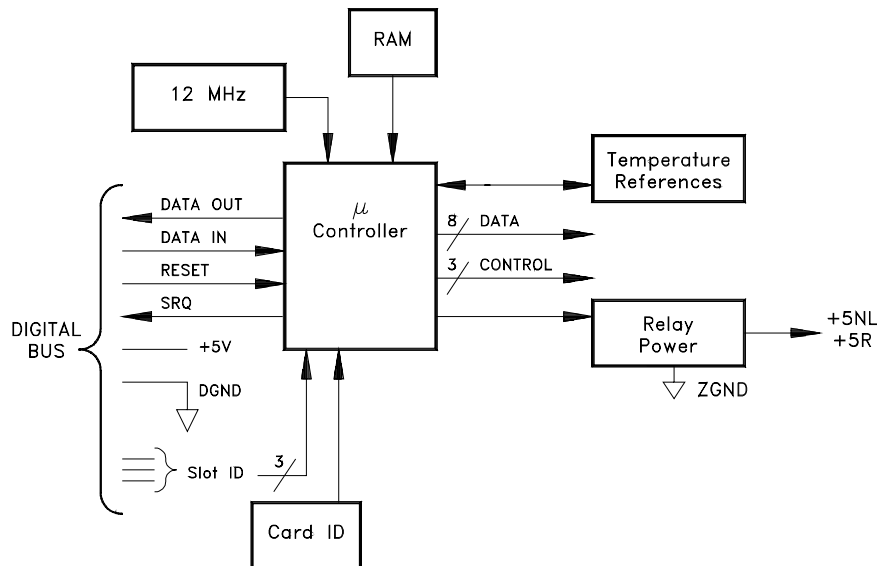

In addition to the +5 Volt power supply (Vcc) and ground, the module controller uses four lines for control and communication:

- RESET, from the Earth Referenced Logic A1U305. RESET is common to all three slots. The module controller performs a reset when this line goes high. Reset conditions vary for each plug-in.
- SRQ, to the Earth Referenced Logic A1U305. The SRQ line is a wired-OR line that can be driven by any plug-in. Consequently, any module that asserts SRQ (line low), asserts this line in all other slots and at the Earth Reference Logic.
- DATA IN, from the Floating Logic A1U205 via the opto-isolator A1U312. This line is connected in common to all three slots.
- DATA OUT, from the module controller to the Floating Logic A1U205 via the opto-isolator A1U213. This line is a wired-OR line that can be driven by any module.

The DATA IN and DATA OUT lines are optically isolated from the floating logic controller. These lines communicate with the Floating Logic using an asynchronous serial bit stream.

The serial communications use an 11 bit protocol; a start bit, 8 data bits, an attention bit, and a stop bit. The attention bit is 1 if the 8 data bits are an address/command, or 0 if the 8 data bits modify or provide data for the previously sent command.

The module controller uses the hardwired slot-ID bits to decode the serial bit stream address. When the address/command message address matches the slot-ID, the plug-in is selected and responds to the following commands. All other plug-ins will ignore the commands until a new address/command message is received.

A 12 MHz crystal, Y101 is the clock for the module controller. The module ID is a four bit pattern set through R106, R107, R108, and R109. The ferroelectric RAM U150 provides data storage of the relay usage on the module (*see page 65*) and the thermocouple reference junction temperature corrections (*see page 122*). Data in and out of U150 is serial.

The 34901A, 34902A, and 34908A each have two onboard, solid state temperature sensors, U151 and U152, physically located near the isothermal block at the input connections. The temperature sensors are used as the thermocouple temperature reference.

U101 controls the relays on the module using an 8-bit data bus and three control lines. The data lines are latched and applied to the relay drivers.

U101 enters a low-power idle mode when inactive. U101 responds when a command is received or when a scheduled reference junction temperature measurement is taken.

The relays use a buffered +5 Volt power supply. U101 supplies two drive enable lines (DR_EN and +5NL_EN) that connect Vcc from the digital bus with the relay drive lines through Q101 (+5R or +5NL). To minimize the current through DGND caused by static discharge, the ground return (ZGND) is isolated from the backplane ground through a bead L102.

Relay Drivers

Two types of single-coil relays are used on the switch modules: *latching* and *non-latching*. Typical driver configurations are shown below.

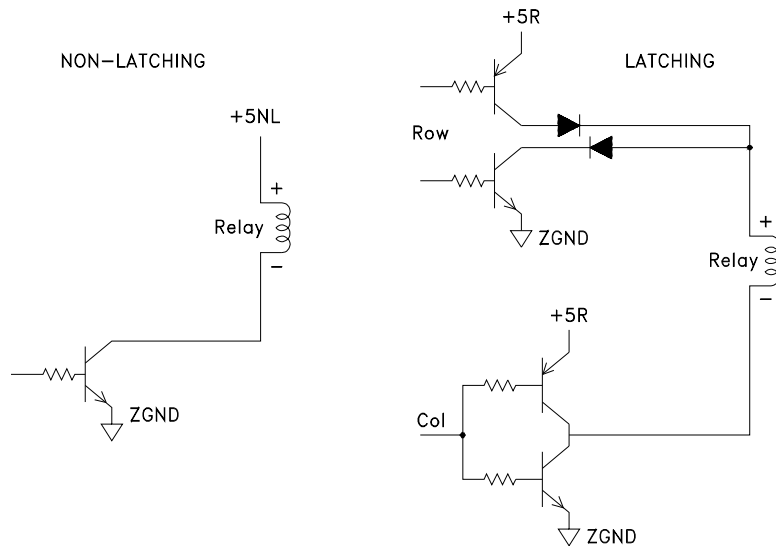

The non-latching relay contacts are in the set position (closed) when current flows through the coil. When the current is removed, the relay resets (opens). The positive side of the relay coil is connected to +5NL. The negative side of the relay coil is connected to ZGND through a single NPN transistor. The transistor and +5NL must be on for the relay to stay in the set position.

The polarity of the current flow through the latching relay coil determines the set (closed) or reset (open) position of the relay contacts. Latching relays are driven by row and column latches or complimentary transistor pairs.

To set a relay (close a channel) in the row column driver circuitry, the appropriate row driver PNP transistor is turned on connecting the +5R supply to the positive side of several relay coils and ZGND is applied to the negative side of the desired relay coil through a column driver NPN transistor. To reset a relay, ZGND is applied through an NPN row driver transistor and +5R through a PNP column driver.

Tree latching relays are driven by complimentary transistor pairs that steer the current through the relay coil.

The +5R supply is only enabled while the relay changes state. The table below shows the times required for the relays to change state.

Switch Module	Open	Close
34901A	6 ms	6 ms
34902A	0.40 ms	1.25 ms
34903A	6 ms	6 ms
34904A	6 ms	6 ms
34905A/06A	10 ms	15 ms
34908A	6 ms	6 ms

34901A

Components in this discussion are located on the A1 circuit assembly (34901-66501).

The control circuitry has four groupings of latches, relay drivers and relays. The three control lines (SEL_A, SEL_B, and SEL_C) from the module controller are divided into five control lines by the binary to octal converter U109.

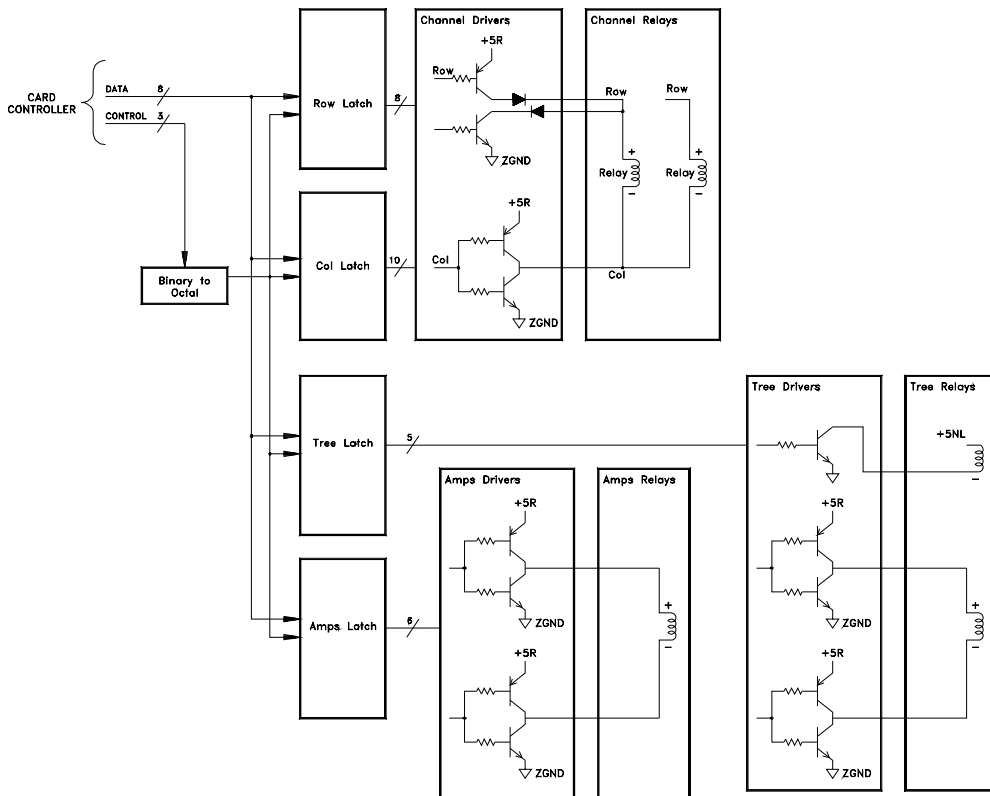

The row latch, U102, and column latches, U103 and U104, control the relays. The row drivers are divided into four groups of set and reset drivers. Each group of row drivers controls five relays. The column drivers operate as a pair. There are ten column drivers each controlling two relays. The analog bus backplane relays are non-latching.

The 20 channels are divided into two banks. The banks are combined by closing K422 for voltage and 2-wire Ohms switching. When K422 is open, the banks are electrically independent of each other and this configuration is used for 4-wire Ohms multiplexing where the Ohms current sources are connected to channels 1 through 10 and the sense is obtained from channels 11 through 20. K421 and K423 control the connection to the analog bus for measurements using the Internal DMM.

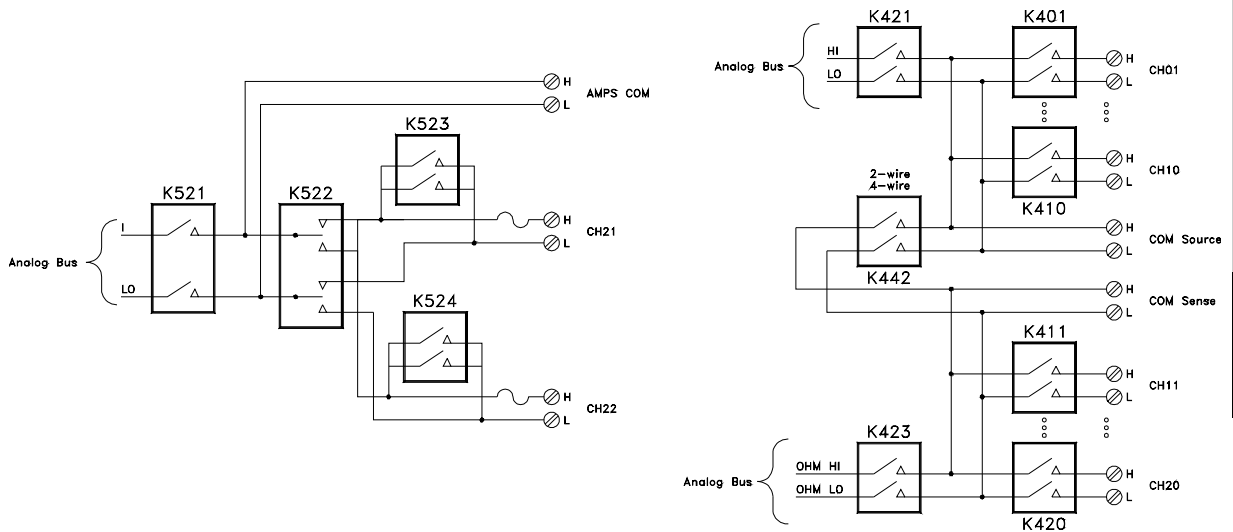

The current measurement channels are selected by relay K522. Relays K523 and K524 short the inputs when a channel is not selected. Relay K521 makes the connection to the analog bus for measurement by the Internal DMM.

34902A

Components in this discussion are located on the A1 circuit assembly (34902-66501).

The control circuitry has two groupings of latches, relay drivers, and relays. The 16 voltage and resistance measurement channels are directly driven. Tree switching controls the 2-wire/4-wire Ohms operation and connections to the analog bus.

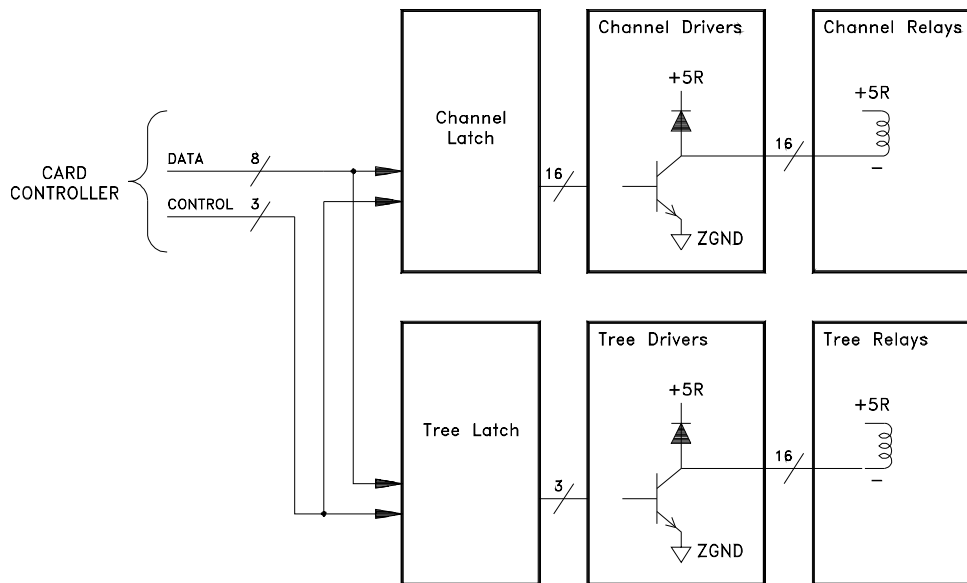

The reed relays are non-latching and the relay driver and +5R is applied while a channel is closed.

The 16 channels are divided into two banks. The banks are combined by closing K327 for voltage and 2-wire Ohms switching. When K327 is open, the banks are electrically independent of each other and this configuration is used for 4-wire Ohms multiplexing where the Ohms current source is connected to channels 1 through 8 and the sense is obtained from channels 9 through 16. Relays K326 and K328 control the connection to the analog bus for measurements using the internal DMM.

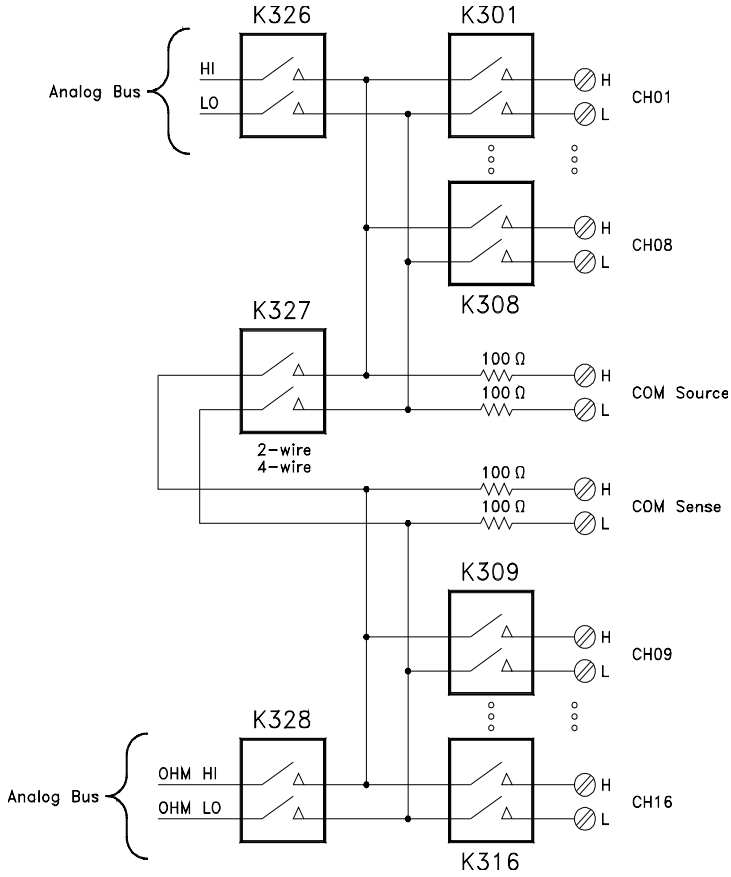

34903A

Components in this discussion are located on the A1 circuit assembly (34903-66501).

The control circuitry has two grouping of latches, relay drivers and relays. The 20 channels are, for control purposes, arranged into 8 rows by 10 columns.

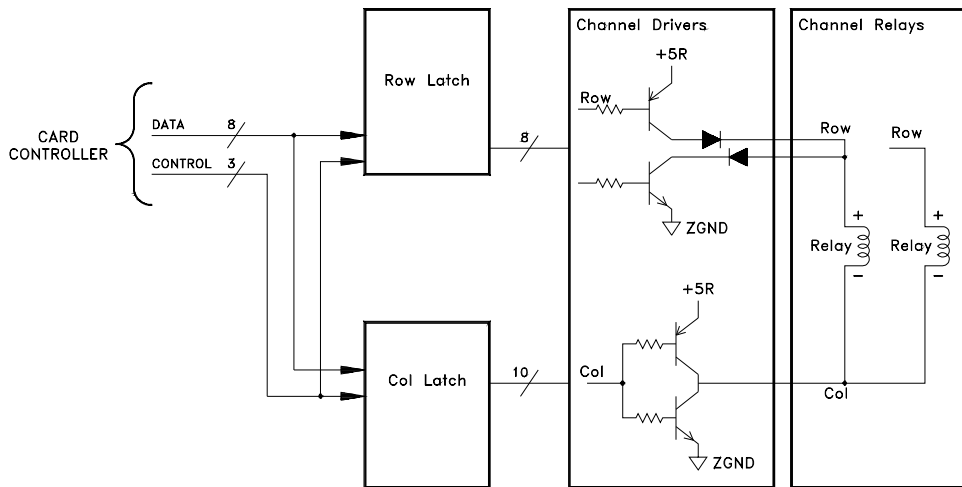

The row latch, U102, and column latches, U103 and U104, control the relays. The row drivers are divided into four groups of set and reset drivers. Each group of row drivers controls five relays. The column drivers operate as a pair. There are ten column drivers each controlling two relays.

The 34903A provides 20 channels of Form C switching.

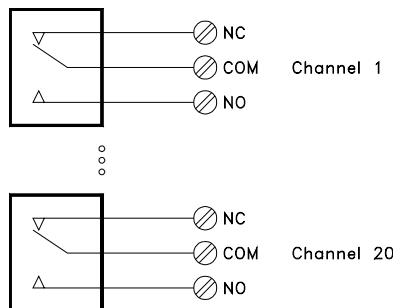

34904A

Components in this discussion are located on the A1 circuit assembly (34904-66501).

The control circuitry has four groupings of latches, relay drivers and relays divided into 4 rows by 8 columns.

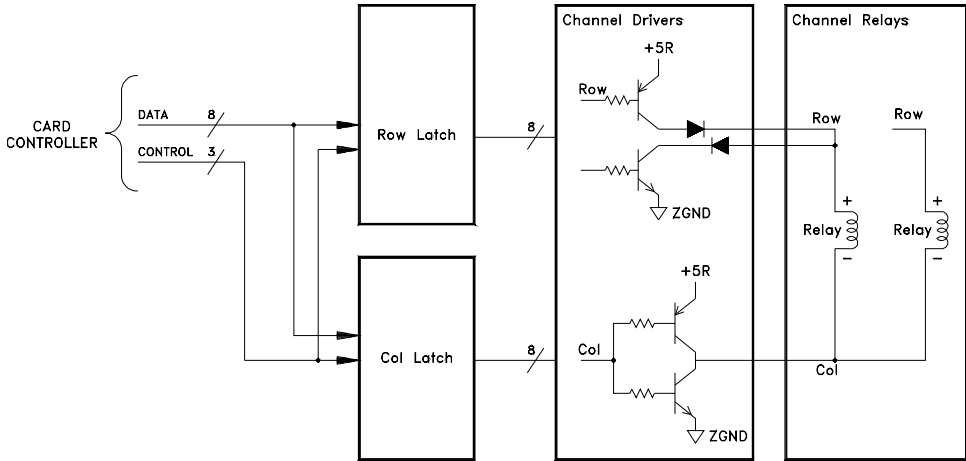

The row latch, U102, and column latch U103, control the relays. The row drivers are divided into four groups of set and reset drivers. Each group of row drivers controls eight relays. The column drivers operate as a pair. There are eight column drivers each controlling four relays. The relays are arranged in 4 rows by 8 columns.

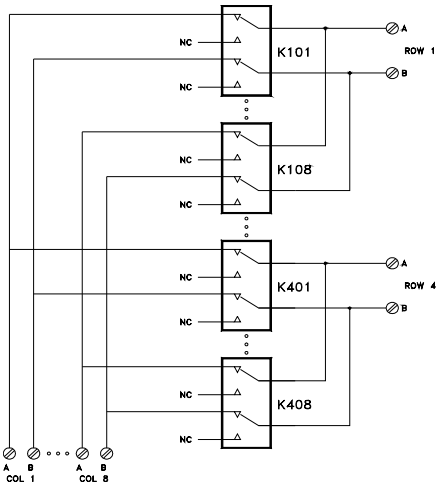

34905A/34906A

Components in this discussion are located on the A1 circuit assembly (34905-66501 or 34906-66501).

The control circuitry has of two grouping of buffers, relay drivers and relays, one for each multiplexer bank.

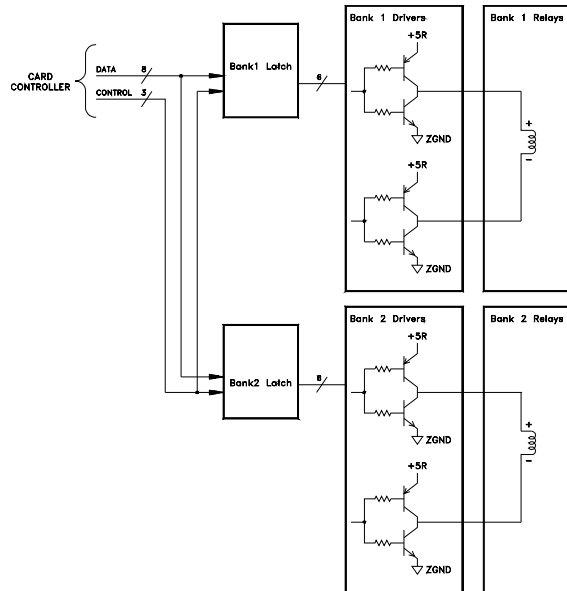

Bank1 latch, U102, and Bank2 latch, U103, control the relays. The bank drivers are divided into six groups of set and reset drivers. Each set and reset driver controls one relay. The column drivers operate as a pair. There are six column drivers each controlling a relay. The relays are arranged into two independent banks:

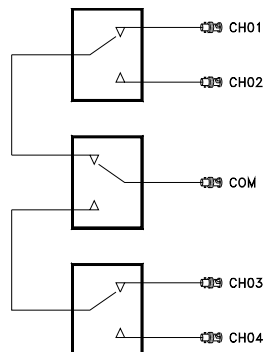

34908A

Components in this discussion are located on the A1 circuit assembly (34908-66501).

The control circuitry has three grouping of latches, relay drivers and relays. The 40 voltage and resistance measurement channels are, for control purposes, arranged into 8 rows by 10 columns. Tree switching controls bank selection and connections to the analog bus.

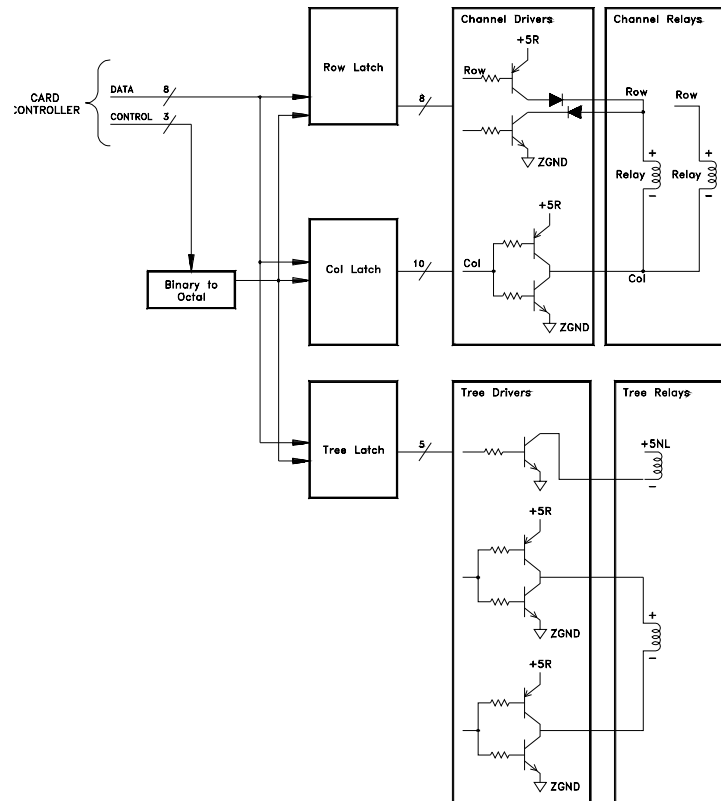

The row latch, U102, and column latches, U103 and U104, control the relays. The row drivers are divided into four groups of set and reset drivers. Each group of row drivers controls five relays. The column drivers operate as a pair. There are ten column drivers each controlling two relays. The analog bus backplane relays are non-latching.

Chapter 5 Theory of Operation

Switch Modules

A single relay is used to switch two input channels. The choice of which channel is connected to the common is performed by relay K422. Channels are paired 20 channels apart (Ch 1 with Ch 21, Ch 2 with Ch 22, etc.) Relay K421 connects the common to the backplane analog bus for use with the internal DMM.

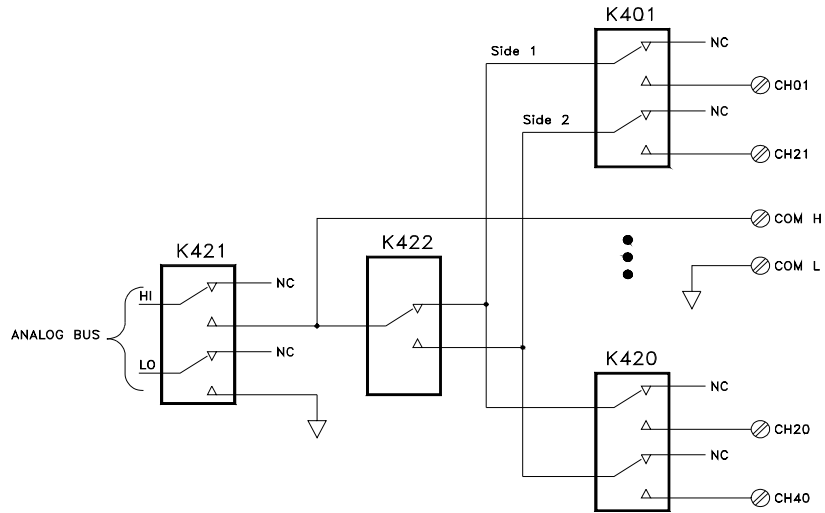

Multifunction Module

The 34907A Multifunction module contains two 8-bit digital input/output ports, a totalizer input, and two 16-bit analog outputs.

Multifunction Control

Components in this discussion are located on the A1 circuit assembly (34907-66501).

A simplified block of the module control circuit is shown below.

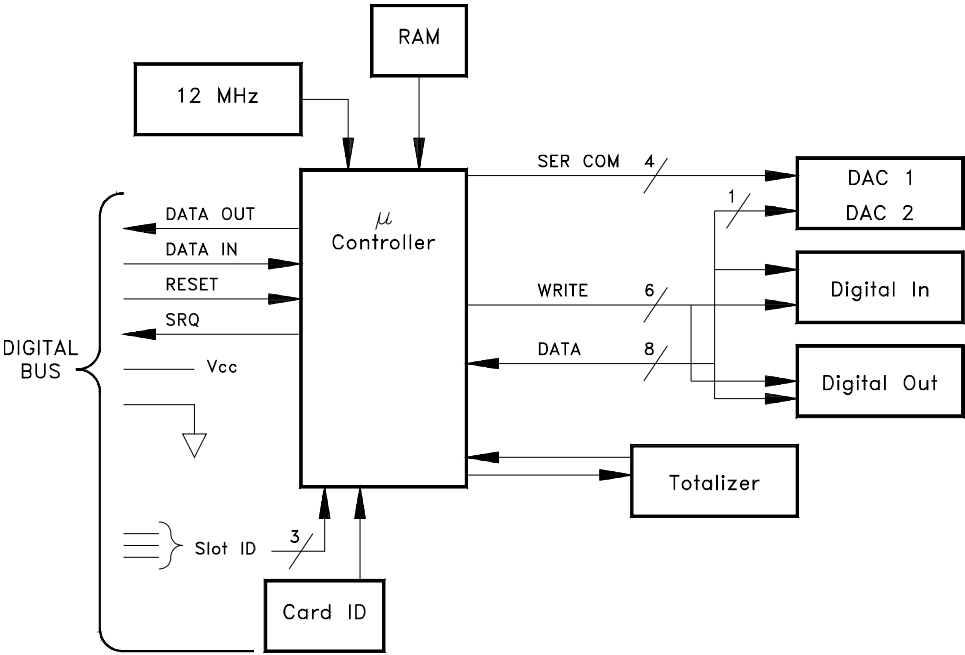

Multifunction Module

In addition to the +5 Volt power supply (Vcc) and ground, the module controller uses four lines for control and communication:

- RESET, from the Earth Referenced Logic A1U305. RESET is common to all three slots. The module controller performs a reset when this line goes high. Reset conditions vary for each plug-in.
- SRQ, to the Earth Referenced Logic A1U305. The SRQ line is a wired-OR line that can be driven by any plug-in. Consequently, any module that asserts SRQ (line low), asserts this line in all other slots and at the Earth Reference Logic.
- DATA IN, from the Floating Logic A1U205 via the opto-isolator A1U312. This line is connected in common to all three slots.
- DATA OUT, from the module controller to the Floating Logic A1U205 via the opto-isolator A1U213. This line is a wired-OR line that can be driven by any module.

The DATA IN and DATA OUT lines are optically isolated from the floating logic controller. These lines communicate with the Floating Logic using an asynchronous serial bit stream.

The serial communications use an 11 bit protocol; a start bit, 8 data bits, an attention bit, and a stop bit. The attention bit is 1 if the 8 data bits are an address/command, or 0 if the 8 data bits modify or provide data for the previously sent command.

The module controller uses the hardwired slot-ID bits to decode the serial bit stream address. When the address/command message address matches the slot-ID, the plug-in is selected and responds to the following commands. All other plug-ins will ignore the commands until a new address/command message is received.

A 12 MHz crystal, Y101, is the clock for the module controller. The module ID is a four bit pattern set through RP102. The ferroelectric RAM U102 provides data storage of the calibration constants for the analog output channels. Data in and out of U102 is serial.

8 data lines, connected to U101 port 1, are used by the digital input and output ports. One of the data lines is used to send serial data to the analog output channels. The totalizer edge count is controlled by U101 P0.6 and read at U101 P3.4.

U101 enters a low-power idle mode when inactive. U101 responds when a command is received or when a scheduled alarm scan is needed.

Totalizer

Components in this discussion are located on the A1 circuit assembly (34907-66501).

A simplified block diagram of the totalizer input is shown below.

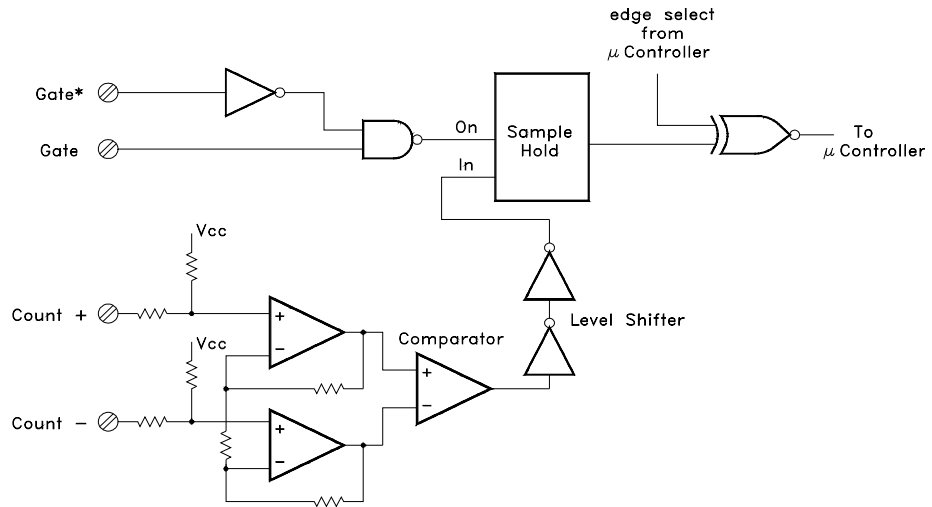

The totalizer counts signals connected to the COUNT+ and COUNT- inputs. Two op-amps, U108A and U108B, are used for input signal conditioning. Comparator U109 determines the signal trigger levels based upon the setting of the jumper at P102. With the P102 jumper in the TTL position, the totalizer counts pulses with TTL trigger levels. With the jumper at P102 in the AC position the trigger level is at zero.

The GATE and GATE* input signals control when counting occurs. If no signal is connected, the totalizer counts any changing signal on the inputs. A TTL low on the GATE input or a TTL high on GATE* input will halt counting.

Count edge selection is controlled from a U101 port bit (P0.6) through the exclusive OR gate U111. When the P0.6 signal is low, the count increments on the rising edge of the input signal. When the P0.6 signal is high, the count increments on the falling edge of the input signal.

Analog Output

Components in this discussion are located on the A1 circuit assembly (34907-66501).

A simplified block diagram of the analog output channels is shown below.

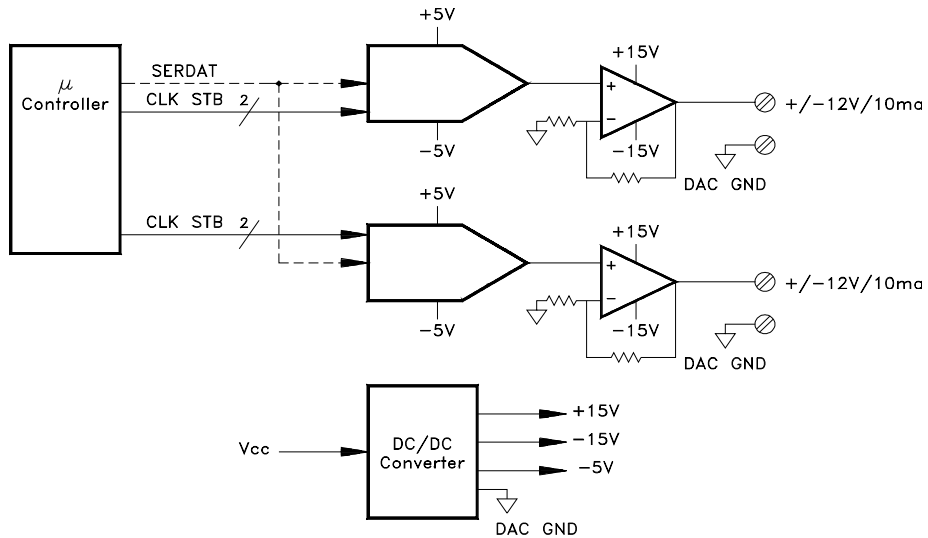

Communication with each DAC (U503 and U504) is via three lines: SERSTB, DACCLK, and SERDAT. Each DAC has a voltage output of ± 3 V. U505 and U506 amplify this voltage to the ± 12 V output.

A DC/DC converter is used to provide the ± 15 V supplies to U505 and U506. The ± 15 V supplies also are used at the input of the totalizer. U502 provides the -5 V supply used by the DACs.

A line from U101 P0.4 is used to control the output of U510. After a reset or power-up, U510 is held in the shutdown state. U101 turns on the DC/DC converter in response to commands from the main controller. The main controller paces the turn on of the DC/DC converters to ensure that if multiple modules are installed, the backplane power supply is not pulled down by the in-rush current of the DC/DC converters.

Digital I/O

Components in this discussion are located on the A1 circuit assembly (34907-66501).

A simplified diagram of a digital I/O channel is shown below.

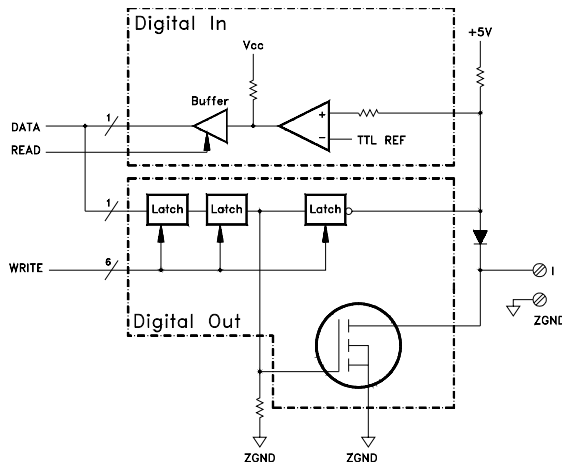

Two stages of latches on the outputs and one set of latches on the inputs provide synchronous 16 bit writes and reads of the digital ports.

For digital output, data is written to the upper and lower bytes (U201 and U202) separately, then latched into the output latches U203 and U204 simultaneously. On a digital input data is latched into the input latches U105 and U106 simultaneously.

MOSFETs are used to provide the low level output, and 74HC240's are used to provide the high level output.

During an output low, a logic high level is applied to the gate of the MOSFET causing it to conduct and creating a low resistance path from the data line to ZGND. In this state the MOSFET is capable of sinking an externally supplied current of up to 400 mA. The blocking diodes, CR301-CR308 and CR401-CR408 prevent any current from sinking into the 74HC240's.

During an output high, a logic low level is applied to the gate of the MOSFET turning it off and presenting a high resistance between the data line and ground.

Multifunction Module

The 74HC240's, U205 and U206, provide the output high drive current necessary to maintain a TTL high output level (= 2.4 VDC) under load.

At instrument turn-on, following a reset, and whenever the data lines are being read, the MOSFETs are in the passive high state, and the high output drivers are disabled. The resistor connected between the MOSFET's gate and ZGND holds the gate near ground potential when the module is initially turned-on to ensure that the MOSFET is in the passive high state.

The comparators U301, U302, U401 and U402 maintain correct TTL high and low levels by shifting the voltages from the input to compensate for the forward voltage drop of the blocking diode. A reference voltage of +2.1 VDC (TTL_REF) is applied to the inverting input of the comparator. When the input voltage is in the range of 0 VDC to +4.3 VDC the blocking diode is forward biased and its forward voltage drop is added to the applied voltage. For example, when 0 VDC is applied to the data line, +0.7 VDC is present on the non-inverting input of the comparator and the comparator output is low. When the input signal level is above 1.4 VDC, a voltage greater than +2.1 VDC is applied to the non-inverting input of the comparator causing its output to go high. When the input signal is less than 1.4 VDC, a voltage less than 2.1 VDC is applied to the comparator's non-inverting input causing its output to go low. This ensures an input voltage < 1.4 VDC is interpreted as a TTL low level and an input > 1.4 VDC is interpreted as a TTL high level.

The pull-up resistor (connected to the comparator's non-inverting input) allows external ground connections and open circuits to be detected. When the data line is grounded, the blocking diode is forward biased applying a +0.7 VDC level to the comparator, a TTL low. When the data line is allowed to float, the non-inverting input of the comparator pulls up to +5 VDC, a TTL high.

The blocking diode on the output is used for circuit protection. The diode reverse biases when the applied voltage exceeds +4.3 VDC preventing externally supplied current from being injected into the module's +5V supply line.

The MOSFETs have a built in zener diode that conducts at any voltage of approximately 75 VDC or greater. The zener diode provides protection from external over voltage situations including static electricity.

Service

Service

This chapter discusses the procedures involved for returning a failed instrument to Agilent for service or repair. Subjects covered include the following:

- Operating Checklist, *on page 169*
- Types of Service Available, *on page 170*
- Repackaging for Shipment, *on page 171*
- Cleaning, *on page 171*
- Electrostatic Discharge (ESD) Precautions, *on page 172*
- Surface Mount Repair, *on page 172*
- To Replace the Power-Line Fuse, *on page 173*
(*also depicted on page 42*)
- Troubleshooting Hints, *on page 173*
- Self-Test Procedures, *on page 177*
- Disassembly, *on page 183*
- Recyclable Parts, *on page 189*
- Parts List for 34970A/34972A and 34901A, *on page 193*

Operating Checklist

Before returning your instrument to Agilent Technologies for service or repair, check the following items:

Is the instrument inoperative?

- Verify that the AC power cord is connected to the instrument.
- Verify that the front-panel On/Standby switch has been pushed.
- Verify that the power-line fuse is installed and not open (see page 50). *The instrument is shipped from the factory with a 500 mA, 250 V fuse. This is the correct fuse for all line voltages.*
- Verify the power-line voltage setting. See “If the Instrument Does Not Turn On” on page 50.

Does the instrument fail self-test?

- Verify that the correct power-line voltage is selected. See “If the Instrument Does Not Turn On” on page 50.
- Remove all input connections to the instrument. *Errors may be induced by AC signals present on the input wiring during a self-test. Long test leads can act as an antenna causing pick-up of AC signals.*

Is the Current measurement function inoperative?

- Verify the input protection fuses on the 34901A Multiplexer Module. If necessary, replace with a 1.5 A, 250 V NTD fuse.

Note: *The Current input is only available on channels 21 and 22 of the 34901A module.*

Types of Service Available

If your instrument or plug-in module fails during the warranty period (within one year of original purchase), Agilent will replace the unit free of charge. After your warranty expires, Agilent will replace the unit at a competitive price. The replacement units are fully refurbished and are shipped with new calibration certificates.

Note: *Each replacement unit has its own serial number. The serial number of the defective unit does not transfer to the replacement unit. The warranty period of the replacement unit is based on the remaining warranty of the defective 34970A/34972A.*

Agilent Unit Exchange



Contact your nearest Agilent Technologies Service Center to arrange to have your instrument replaced. In the U.S. call 800-829-4444. Select "Option 3" followed by "Option 1."

Note: *Agilent Unit Exchange applies to the 34970A/34972A mainframe only. Plug-in modules are not supported as exchange assemblies.*

When exchanging the 34970A/34972A, do not ship plug-in modules with your instrument. Remove all plug-in modules and customer wiring before shipping the unit to Agilent.

Note: *The defective unit must be returned to Agilent before the replacement unit is shipped to you. Additional information regarding unit exchange will be provided when you contact Agilent.*

Repackaging for Shipment

If the unit is to be shipped to Agilent for service or repair, be sure to:

- Attach a tag to the unit identifying the owner and indicating the required service or repair. Include the instrument model number and your full serial number.
- Place the unit in its original container with appropriate packaging material.
- Secure the container with strong tape or metal bands.

If the original shipping container is not available, place your unit in a container which will ensure at least 4 inches of compressible packaging material around all sides for the instrument. Use static-free packaging materials to avoid additional damage to your unit.

Agilent suggests that you always insure shipments.

Cleaning

Unplug the instrument before cleaning it. Clean the outside of the instrument and plug-in modules with a soft, lint-free, slightly dampened cloth. Do not use detergent. Disassembly is not required or recommended for cleaning.

Electrostatic Discharge (ESD) Precautions

Almost all electrical components can be damaged by electrostatic discharge (ESD) during handling. Component damage can occur at electrostatic discharge voltages as low as 50 volts.

The following guidelines will help prevent ESD damage when servicing the instrument or any electronic device.

- Disassemble instruments *only* in a static-free work area.
- Use a conductive work area to dissipate static charge.
- Use a conductive wrist strap to dissipate static charge accumulation.
- Minimize handling.
- Keep replacement parts in original static-free packaging.
- Remove all plastic, styrofoam, vinyl, paper, and other static-generating materials from the immediate work area.
- Use *only* anti-static solder suckers.

WARNING

SHOCK HAZARD. Only service-trained personnel who are aware of the hazards involved should remove the instrument covers. To avoid electrical shock and personal injury, make sure to disconnect the power cord from the instrument before removing the covers.

Surface Mount Repair

Surface mount components should *only* be removed using soldering irons or desoldering stations *expressly* designed for surface mount components. *Use of conventional solder removal equipment will almost always result in permanent damage to the printed circuit board and will void your Agilent factory warranty.*

To Replace the Power-Line Fuse

The power-line fuse is located on the rear panel of the instrument, near the power line connector. A procedure to replace the fuse is given on page 50. Use a 500 mA, 250 V fuse for all power line settings.

Troubleshooting Hints

This section provides a brief check list of common failures. Before troubleshooting or repairing the instrument, make sure the failure is in the instrument rather than any external connections. Also make sure that the instrument is accurately calibrated within the last year (*see page 73*). The instrument's circuits allow troubleshooting and repair with basic equipment such as a 6½-digit multimeter.

Unit is Inoperative

- Verify that the AC power cord is connected to the instrument.
- Verify that the front-panel On/Standby switch has been pushed.
- Verify that the power-line fuse is installed and not open (*see page 50*). *The instrument is shipped from the factory with a 500 mA, 250 V fuse.*
- Verify the power-line voltage setting. *See "If the Instrument Does Not Turn On" on page 50.*
- Remove all plug-in modules to verify that a plug-in module is not causing the failure.

Unit Reports Error 705

This error may be produced if you accidentally turn off power to the unit during a calibration or while changing a non-volatile state of the instrument. Recalibration or resetting the state should clear the error. If the error persists, a hardware failure may have occurred.

Isolating to an Assembly

- Remove all plug-in modules to isolate between the instrument and the plug-in modules.
- Listen for a beep when you press the On/Standby switch. The main controller can operate the beeper even with a display failure.
- Listen for the fan when you press the On/Standby switch. Fan operation indicates some operation of the main controller and power supplies.
- Try to operate the instrument from a remote interface. If remote operations are normal, the display should be replaced or repaired.
- Isolate the internal DMM by removing it. The instrument should operate and pass self-test without the internal DMM installed. Disassembly procedures start on page 183.

Unit Fails Self-Test

- Verify that the correct power-line voltage setting is selected.
- Remove all plug-in modules and run self-test again. If the instrument does not show a failure, replace or troubleshoot the plug-in module.
- To isolate the internal DMM, disassemble the instrument and remove the internal DMM. Disassembly procedures start on page 183. Run self-test again. If the self-test passes, troubleshoot or replace the Internal DMM. If the self-test fails, troubleshoot or replace the 34970A/34972A.

Power Supplies

Verify the power supplies generated on the 34970-66501 circuit board.

The front panel filament voltage, + 5 V backplane and +5 V fan are switched by the On/Standby switch. All other power supplies operate whenever the AC power cord is connected.

To check the power supplies, remove the instrument cover as shown on page 183. The power supplies can be checked from the bottom of the instrument as shown below. Be sure to use the correct ground point when checking the supplies.

WARNING

- Exposed Mains
- Do not Touch!

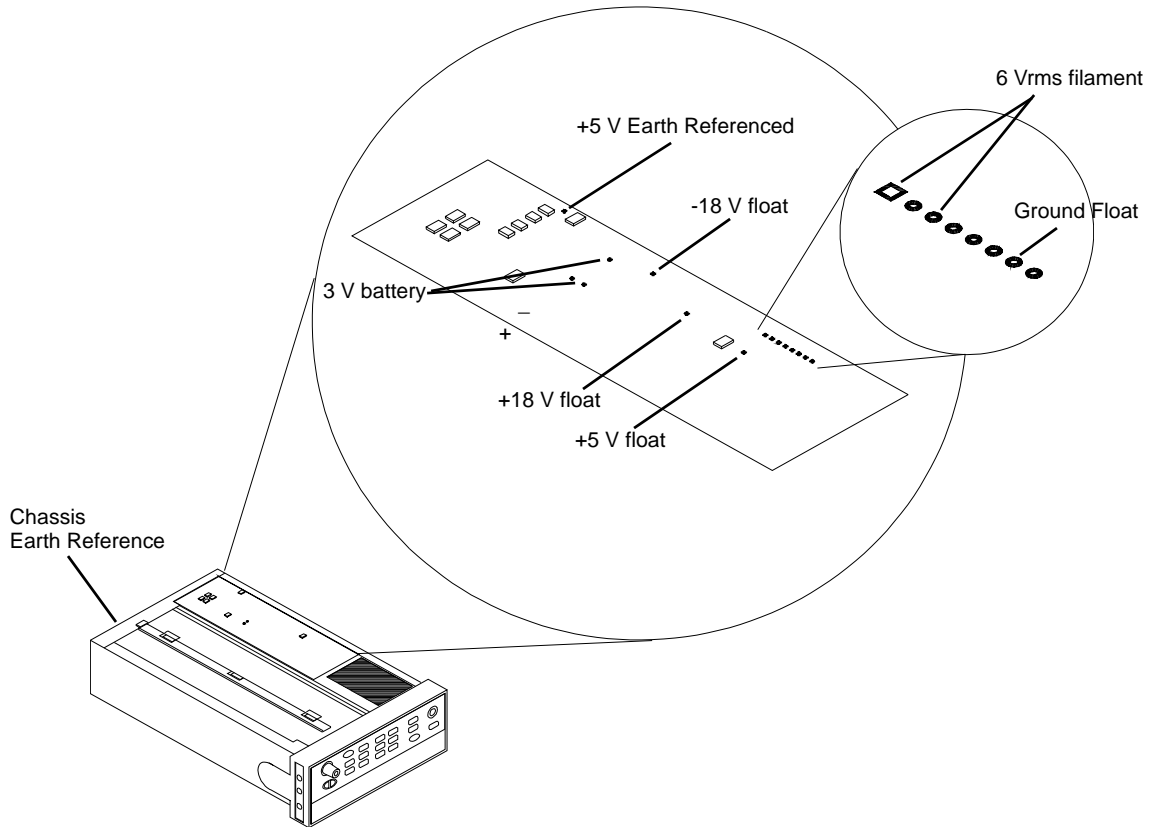

Chapter 6 Service

Troubleshooting Hints

If you need to change the battery on the 34972A, be sure to unplug the instrument first. Use a CR2032 3V lithium battery, and insert the battery with the + side up. If you do not have a new battery, do not discard the old battery, as the instrument will not boot up without a battery - even a dead one - in place. Dispose of the old battery in accordance with local regulations.

Changing the battery is recommended at the instrument's annual calibration. Do not attempt to change the battery on the 34970A.

The A1 power supplies are tabulated below.

Power Supply	Minimum	Maximum	Switched
+5 Earth Ref.	4.75 V	5.25 V	No
+5 Backplane and Fan	4.75 V	5.25 V	Yes
+5 Floating	4.75 V	5.25 V	No
+18 Floating	17.6 V	19.9 V	No
-18 Floating	-19.0 V	-16.8 V	No
6 Vrms Filament			Yes

- Check that the input to the supply voltage regulator is at least 1 V greater than its output.
- Circuit failures can cause heavy supply loads which may pull down the regulator output voltage.
- Always check that the power supplies are free of AC oscillations using an oscilloscope.
- All plug-in modules use the +5 V backplane supply. Some plug-in modules generate their own local power supplies.

Self-Test Procedures

Power-On Self-Test

Each time the instrument is powered on, a small set of self-tests are performed. These tests check that the minimum set of logic and measurement hardware are functioning properly. Any plug-in modules installed are verified for two-way communication with the main controller.

Complete Self-Test

Hold down any front panel key for 5 seconds while turning on the power to perform a complete self-test. The instrument beeps when the test starts. If all self-tests pass the display shows PASS for five seconds and the instrument returns to the last measurement function.

Plug-in Module Self-Test

No user self-test exists for the plug-in modules. The plug-in modules perform their own self-test when power is applied. Additionally, the mainframe checks two-way communication with all plug-in modules at power on.

Each plug-in module also performs error checking at regular intervals during operation and any errors detected are reported via the status system to the main controller.

Note: *The following pages contain a subset of the 34970A/34972A error messages. Refer to the 34970A/34972A User's Guide for the complete error message listing.*

Self-Tests

A complete self-test performs the following tests. A failing test is indicated by the test number and description in the display. For a complete list of error messages, see Chapter 5 in the *Agilent 34970A/34972A User's Guide*.

- 601 Front panel not responding** The main CPU A1U205 attempts to establish serial communications with the front panel processor A2U1. During this test, A2U1 turns on all display segments. Communication must function in both directions for this test to pass. If this error is detected during power-up self-test, the instrument will beep. This error is only readable from the remote interface.
- 602 RAM read/write failed** This test writes and reads a 55 η and AA η checkerboard pattern to each address of RAM. Any incorrect readback will cause a test failure. This error is only readable from the remote interface.
- 603 A / D sync stuck** The main CPU issues an A / D sync pulse to A1U209 and A1U205 to latch the value in the ADC slope counters. A failure is detected when a sync interrupt is not recognized and a subsequent time-out occurs.
- 604 A / D slope convergence failed** The input amplifier is configured to the measure zero (MZ) state in the 10 V range. This test checks whether the ADC integrator produces nominally the same number of positive and negative slope decisions ($\pm 10\%$) during a 20 ms interval.
- 605 Cannot calibrate rundown gain** This test checks the nominal gain between the integrating ADC and the A1U205 on-chip ADC. This error is reported if the procedure can not run to completion due to a hardware failure.
- 606 Rundown gain out of range** This test checks the nominal gain between the integrating ADC and the A1U205 on-chip ADC. The nominal gain is check to $\pm 10\%$ tolerance.

- 607** **Rundown too noisy** This test checks the gain repeatability between the integrating ADC and the A1U205 on-chip ADC. The gain test (606) is performed eight times. Gain noise must be less than ± 64 LSBs of the A1U205 on-chip ADC.
- 608** **Serial configuration readback failed** This test re-sends the last 9 byte serial configuration data to all the serial path. The data is then clocked back into A1U209 and compared against the original 9 bytes sent. A failure occurs if the data do not match.
- 609** **DC gain x1 failed** This test configures for the 10 V range. The DC amplifier gain is set to X1. The measure customer (MC) input is connected to the internal TSENSE source which produces 0.6 volts. A 20 ms ADC measurement is performed and checked against a limit of $0.6\text{ V} \pm 0.3\text{ V}$.
- 610** **DC gain x10 failed** This test configures for the 1 V range. The DC amplifier gain is set to X10. The measure customer (MC) input is connected to the internal TSENSE source which produces 0.6 volts. A 20 ms ADC measurement is performed and checked against a limit of $0.6\text{ V} \pm 0.3\text{ V}$.
- 611** **DC gain x100 failed** This test configures for the 100 mV range. The DC amplifier gain is set to X100. The measure customer (MC) input is connected to the internal TSENSE source which produces 0.6 volts. A 20 ms ADC measurement is performed and checked for a + overload response.
- 612** **Ohms 500 nA source failed** This test configures to the 10 V DC range with the internal 10 M 100:1 divider A4U102 connected across the input. the 500 nA Ohms current source is connected to produce a nominal 5 V signal. A 20 ms ADC measurement is performed and the result is checked against a limit of $5\text{ V} \pm 1\text{ V}$.

- 613 Ohms 5 μ A source failed** This test configures the 10 V range with the internal 10 M 100:1 divider A4U102 connected across the input. The 5 μ A current source is connected. The compliance limit of the current source is measured. A 20 ms ADC measurement is performed and the result is checked against a limit of $7.5 \text{ V} \pm 3 \text{ V}$.
- 614 DC 300V zero failed** This test configures the 300 V DC range with no input applied. A 20 ms ADC measurement is performed and the result is checked against a limit of $0 \text{ V} \pm 5 \text{ mV}$.
- 615 Ohms 10 μ A source failed** This test configures the 10 V range with the internal 10 M 100:1 divider A4U102 connected across the input. The 10 μ A current source is connected. A 20 ms ADC measurement is performed and the result is checked against a limit of $7.5 \text{ V} \pm 3 \text{ V}$.
- 616 DC current sense failed** This test configures the 1 A DC range and function. A 20 ms ADC measurement is performed and the result is checked against a limit of $0 \text{ A} \pm 5 \text{ A}$. This test confirms that the DC current sense path is functional.
- 617 Ohms 100 μ A source failed** This test configures the 10 V range with the internal 10 M 100:1 divider A4U102 connected across the input. The 100 μ A current source is connected. The compliance limit of the current source is measured. A 20 ms ADC measurement is performed and the result is checked against a limit of $5 \text{ V} \pm 1 \text{ V}$.
- 618 DC high voltage attenuator** This test configures to the 300 VDC range. the 500 nA ohms current source is connected to produce a nominal 5 V signal. A 20 ms ADC measurement is performed and the result is checked against a limit of -10 mV to 70 mV at the output of the rms-to-dc converter.

- 619** **Ohms 1 mA source failed** This test configures the 10 V range with the internal 10 M 100:1 divider A4U102 connected across the input. The 1 mA current source is connected. A 20 ms ADC measurement is performed and the result is checked against a limit of $7\text{ V} \pm 3.5\text{ V}$.
- 620** **AC rms zero failed** This test configures to the 100 mV AC range with the AC input grounded through A4K103. The internal residual noise of the AC section is measured and checked against a limit of -10 mV to 70 mV at the output of the rms-to-dc converter.
- 621** **AC rms full scale failed** This test configures for the 100 mV AC range. The 1 mA ohms current source is switched on the charge the AC input capacitor A4C301. This produces a pulse on the output of the rms-to-dc converter which is sampled 100 ms after the current is applied. A 20 ms A/D measurement is performed and checked against a limit of $10\text{ V} \pm 8.5\text{ V}$ into the ADC.
- 622** **Frequency counter failed** This test configures for the 100 mV AC range. This test immediately follows test 621. With A4C301 holding charge from test 621 the AC input is now switched to ground through A4K103. This produces a positive pulse on the input to the frequency comparator A4U310. While C301 discharges, the ENAB FREQ bit is toggled four times to produce a frequency input to the counter logic in A1U205. A failure occurs if the counter can not measure the frequency input.
- 623** **Cannot calibrate precharge** This test configures to the 100 V DC range with no input. The ADC is configured for 200 ms measurements. The A1U205 pulse width modulated (PWM) DAC output (C224) is set to about 4 volts. A reading is taken in with A4U101 in the MC state. A second reading is taken in the PRE state. The precharge amplifier voltage offset is calculated. The A1U205 DAC output is set to about 1.5 volts and the precharge offset is measured again. The gain of the offset adjustment is calculated. This test assures a precharge amplifier offset is achievable.

- 624** **Unable to sense line frequency** This test checks that the LSENSE logic input to A1U205 is toggling. If no logic input is detected, the meter will assume a 50 Hz line operation for all future measurements.
- 625** **I/O processor did not respond** This test checks that communications can be established between A1U205 and A1U305 through the optically isolated (A1U213 and A1U214) serial data link. Failure to establish communication in either direction will generate an error. If this condition is detected at power-on self-test, the instrument will beep and the error annunciator will be on.
- 626** **I/O processor failed self-test** A failure occurred when the earth referenced processor, AU305, executed an internal RAM test.

Disassembly

The following tools are recommended for disassembly.

- T15 Torx® driver (all screws)
- 11 mm nut driver (front-panel disassembly)
- 5 mm nut driver (rear-panel connectors)

Tighten the fan screws to a maximum of 6 in/lbs (0.68 newton/meter).

WARNING

SHOCK HAZARD. Only service-trained personnel who are aware of the hazards involved should remove the instrument covers. Dangerous voltages may be encountered with the instrument covers removed.

CAUTION

To prevent damage to the fan, do not over tighten the fan screws.

General Disassembly

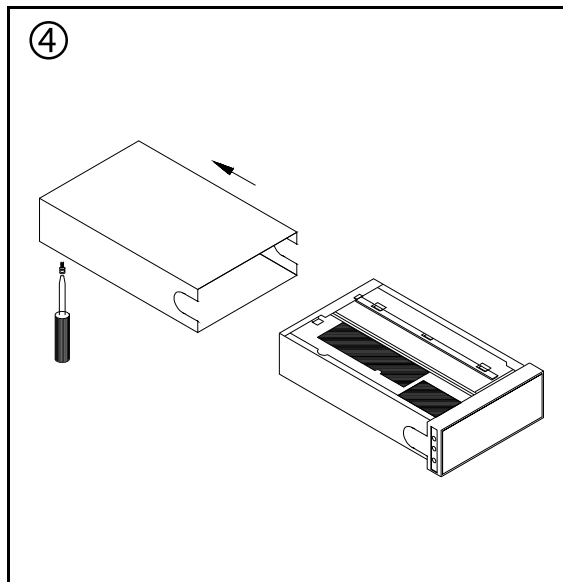
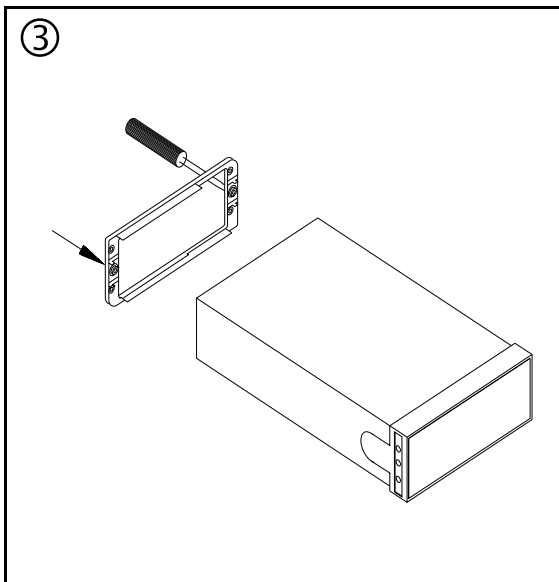
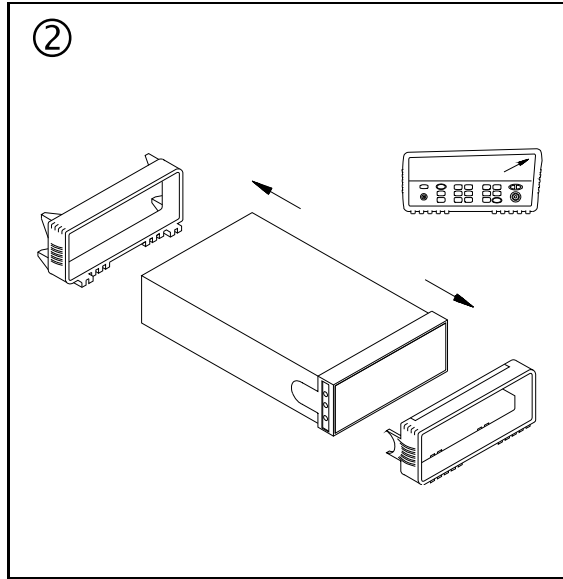
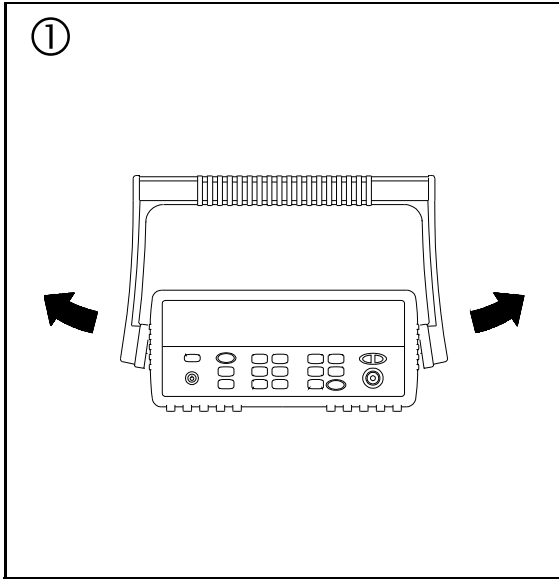

Internal DMM Disassembly

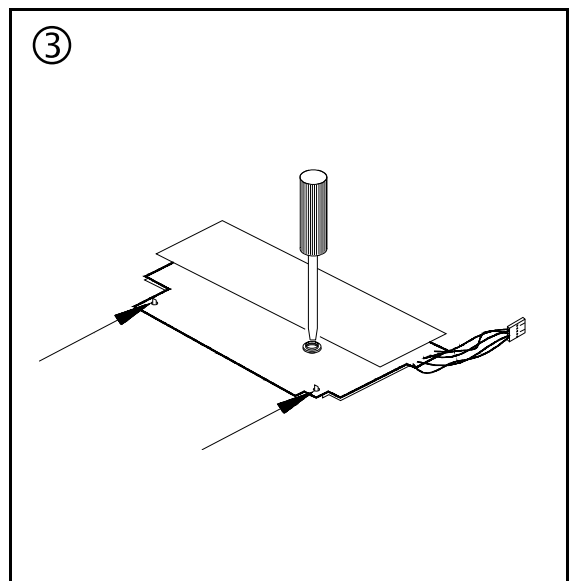
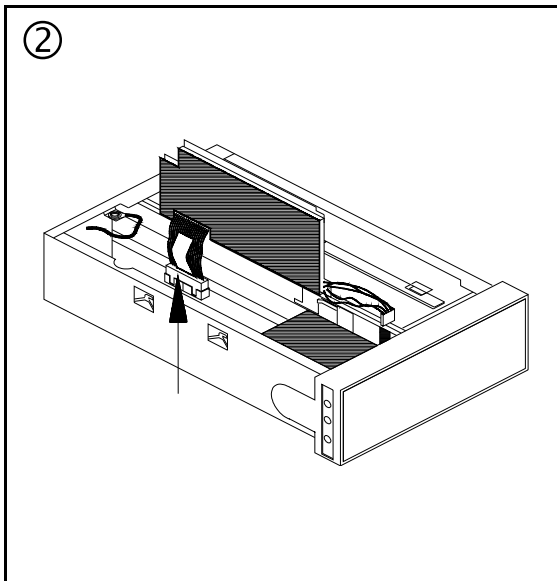
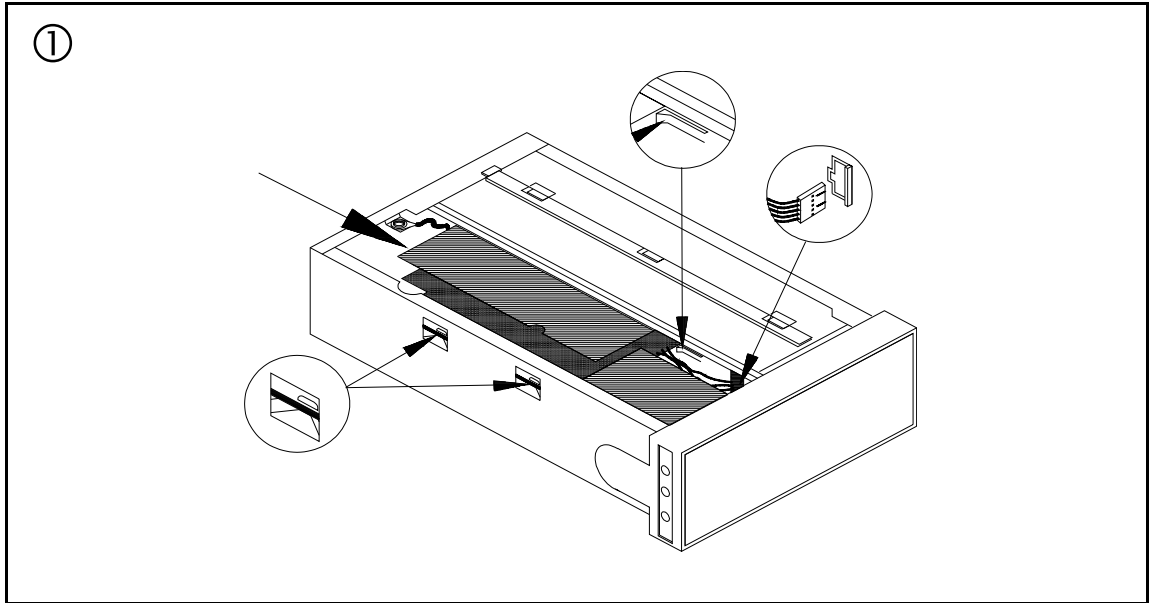

Front Panel Disassembly

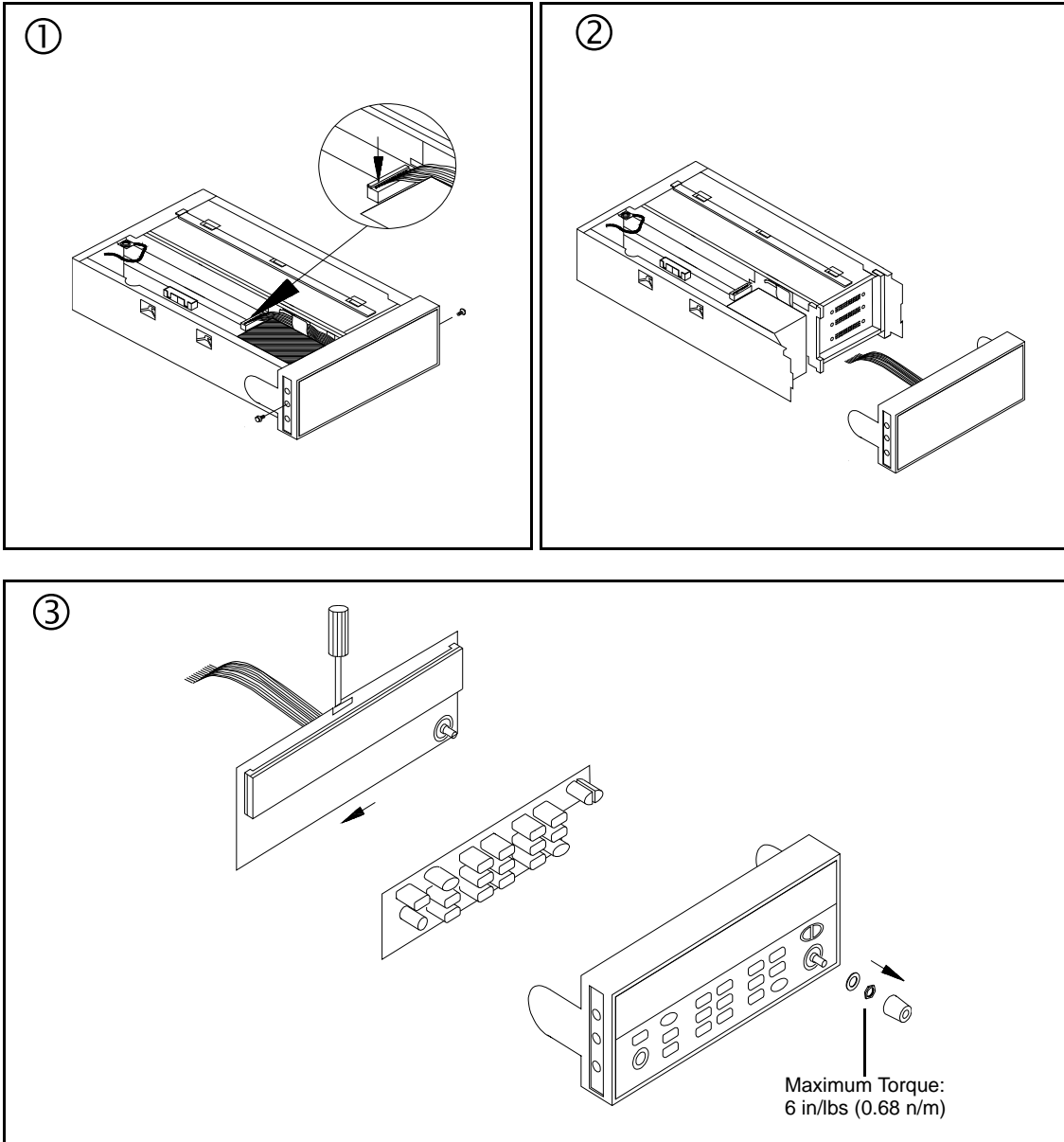

Note: When reassembling the front panel, be sure to route the front panel cable as shown above. Do not allow the front-panel cable to touch the digital ribbon cable.

Additional Chassis Disassembly

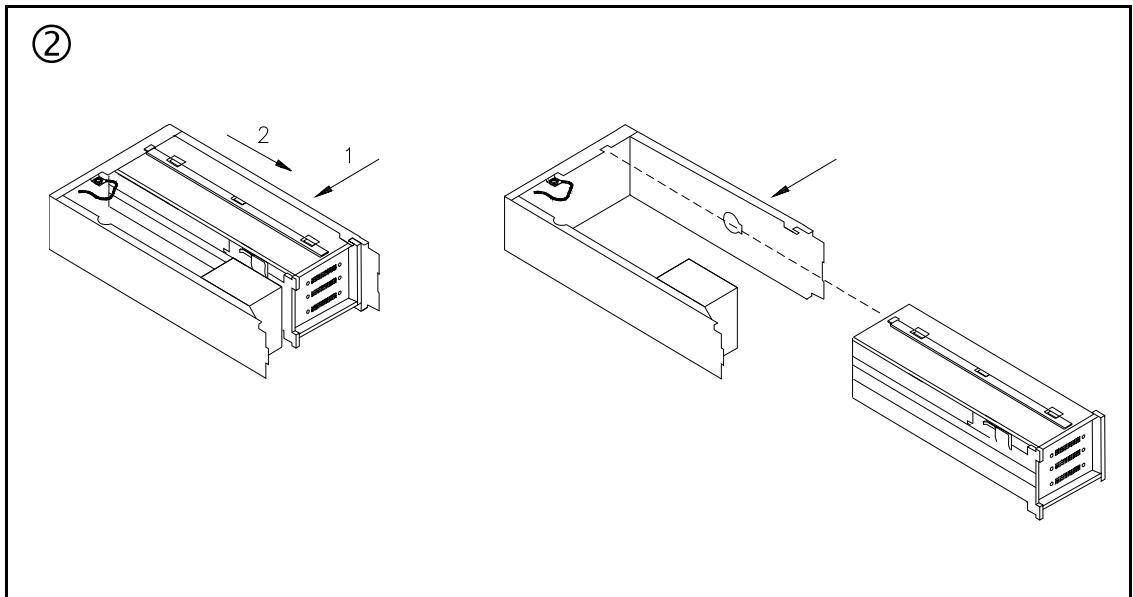
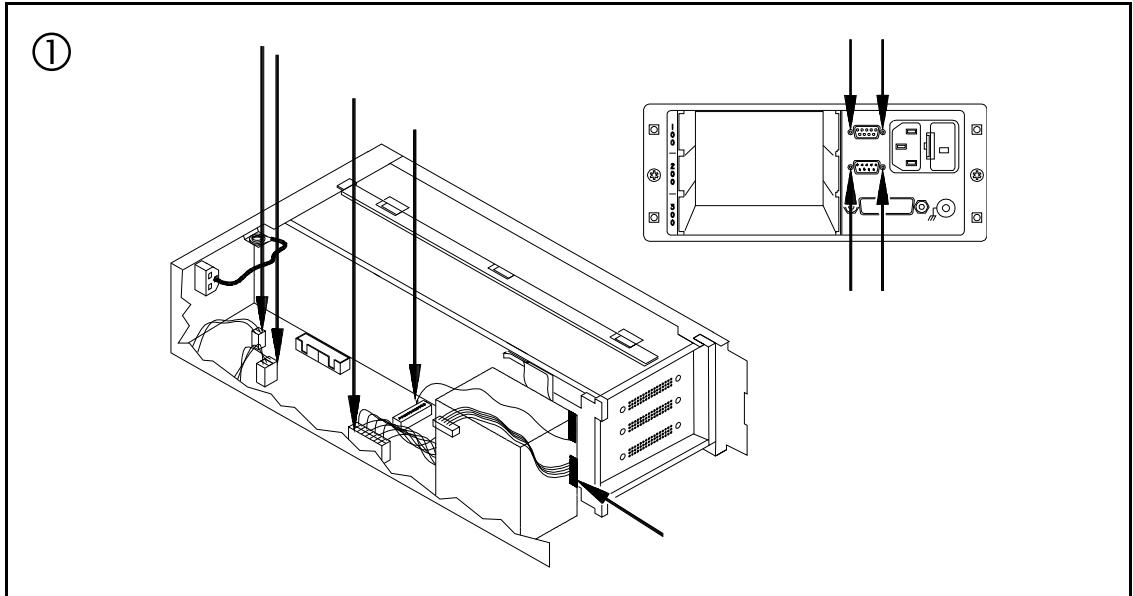

Plug-In Module Disassembly

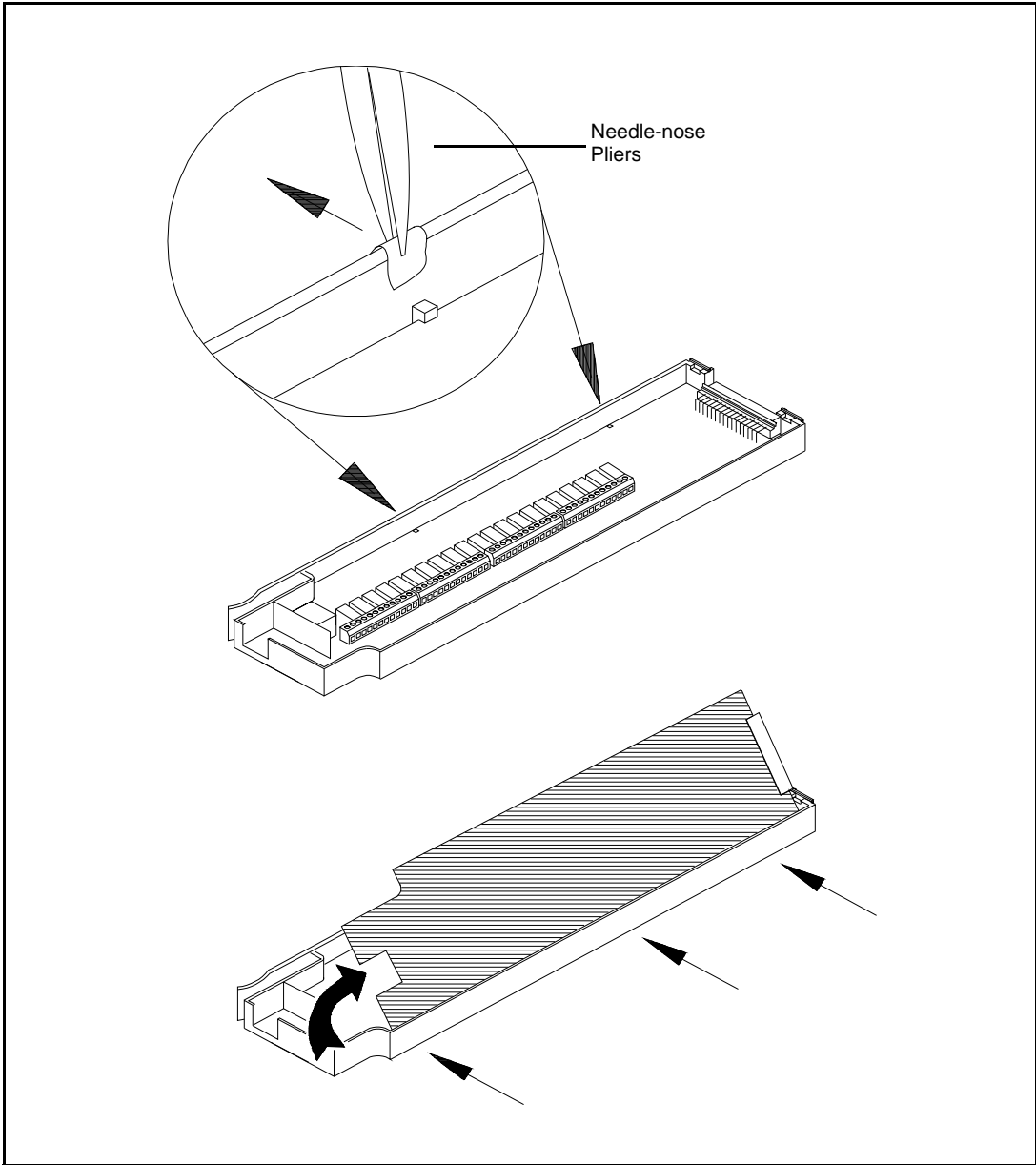

Recyclable Parts

The following table identifies the plastic components in your instrument that must be recycled when the instrument is disposed of.

Part Number	Description	Image
34970-00101 (Quantity: 1)	Card Cage - Left 10% Glass Filled Polycarbonate	
34970-00102 (Quantity: 1)	Card Cage - Right 10% Glass Filled Polycarbonate	
34970-40201 (Quantity: 1)	Front Panel Polycarbonate/ ABS	

Chapter 6 Service
Disassembly

Part Number	Description	Image
34970-88001 (Quantity: 1)	Keypad Silicone Rubber	
34970-87401 34972-87401 (Quantity: 1)	Knob Santoprene and 20% GF Polypropylene	
34970-88302 (Quantity: 1)	Rear Bezel Polycarbonate	

Part Number	Description	Image
34401-86020 (Quantity: 1)	Bumpers Front/ Rear Santoprene	
34401-45021 (Quantity: 1)	Handle Polycarbonate/ ABS	
34970-49321 34972-49321 (Quantity: 1)	Window Polycarbonate	
34970-44111 (Quantity: 2)	Cover 10% Glass Filled Polycarbonate	

Replaceable Parts

This section contains information on ordering replacement parts for your instrument. The parts list includes brief descriptions of the part with applicable Agilent part numbers.

To Order Replaceable Parts

You can order replaceable parts from Agilent using the Agilent part number. All parts listed in this chapter are available as field-replaceable parts. To order replaceable parts from Agilent, do the following:

- 1** Contact your nearest Agilent Sales Office or Service Center.
- 2** Identify the parts by the part number shown in the replaceable parts list. Note that not all parts are directly available from Agilent; you may have to order certain parts from the specified manufacturer.
- 3** Provide the instrument model number and serial number.

■ **Parts List for 34970A/34972A and 34901A**

Part Number	Part Description
1420-0860	34970A BATTERY 3V 850A-HR LI MANGANESE DIOXIDE
34970-49321	34970A WINDOW/FRONT
34970-87401	34970A KNOB
RS232-61601	34970A Cable, RS232, 9 pin
0960-0961	MECHANICAL ENCODER 2 BIT 24 POSITION.
34970-66502	PCA-Display bd
34970-68511	FAN ASSEMBLY
34970-80010	DMM Field Installation Kit
34970-86201	PWR MOD W/FUSE
34970-88302	BEZEL-REAR
34970-87901	Transformer
34401-86010	Bumper Kit
34401-45011	Handle
34970-84131	COVER-PAINTED ALUMINIUM
34972-87401	34972A Knob
8121-1074	USB Cable
34972-49321	34972A WINDOW/FRONT
1420-0356	34972A Battery
2110-0458	Fuse: 500 mA (for 34970A and 34972A)
2110-0043	FUSE (INCH) 1.5A 250V NTD FE UL-LST (for 34901A)

Chapter 6 Service
Parts List for 34970A/34972A and 34901A