

Agilent N9320B RF Spectrum Analyzer

Quick Start Guide



Agilent Technologies

Notices

© Agilent Technologies, Inc. 2008

No part of this manual may be reproduced in any form or by any means (including electronic storage and retrieval or translation into a foreign language) without prior agreement and written consent from Agilent Technologies, Inc. as governed by United States and international copyright laws.

Edition

First Edition

Printed in China, August 2008

Agilent Technologies, Inc.
Qianfeng Hi-Tech Industrial Park
Chengdu Hi-Tech Industrial Development
Zone(West District)
Chengdu, 611731, P.R.C

Software Revision

This guide is valid for A.01.00 revisions of the N9320B RF Spectrum Analyzer software.

Warranty

The material contained in this document is provided “as is,” and is subject to being changed, without notice, in future editions. Further, to the maximum extent permitted by applicable law, Agilent disclaims all warranties, either express or implied, with regard to this manual and any information contained herein, including but not limited to the implied warranties of merchantability and fitness for a particular purpose. Agilent shall not be liable for errors or for incidental or consequential damages in connection with the furnishing, use, or performance of this document or of any information contained herein. Should Agilent and the user have a separate written agreement with warranty terms covering the material in this document that conflict with these terms, the warranty terms in the separate agreement shall control.

Technology Licenses

The hardware and/or software described in this document are furnished under a license and may be used or copied only in accordance with the terms of such license.

Restricted Rights Legend

U.S. Government Restricted Rights. Software and technical data rights granted to the federal government include only those rights customarily provided to end user customers. Agilent provides this customary commercial license in Software and technical data pursuant to FAR 12.211 (Technical Data) and 12.212 (Computer Software) and, for the Department of Defense, DFARS 252.227-7015 (Technical Data - Commercial Items) and DFARS 227.7202-3 (Rights in Commercial Computer Software or Computer Software Documentation).

Safety Notices

CAUTION

A **CAUTION** notice denotes a hazard. It calls attention to an operating procedure, practice, or the like that, if not correctly performed or adhered to, could result in damage to the product or loss of important data. Do not proceed beyond a **CAUTION** notice until the indicated conditions are fully understood and met.

WARNING

A **WARNING** notice denotes a hazard. It calls attention to an operating procedure, practice, or the like that, if not correctly performed or adhered to, could result in personal injury or death. Do not proceed beyond a **WARNING** notice until the indicated conditions are fully understood and met.

Contents

1	Getting Started	1
	Check the Shipment and Order List	2
	Options	3
	Safety Notice	4
	Power Requirements	5
	Power On and Check	7
	Running Internal Alignments	8
	Check for Instrument Messages	8
	Environmental Requirements	9
	Electrostatic Discharge Protection	12
2	N9320B Overview	13
	Agilent N9320B at a Glance	14
	Front Panel at a Glance	15
	Display Annotations	18
	Rear Panel Overview	20
	Front and rear panel symbols	21
3	Basic Operation	23
	Making a Basic Measurement	24
	Using the Front Panel	24
	Presetting the Spectrum Analyzer	25
	Viewing a Signal	26
	Some helpful Tips	28

Contents

Set system date and time	28
Enable the Options	28
Using an External Reference	28
Firmware Update	29
Remote Control	30
Installing Agilent IO libraries suite	30
USB Connection	31
LAN Connection	31
4 Troubleshooting	33
Check the basics	34
Warranty and Service Options	35
Contact Agilent Technologies	36
Index	37

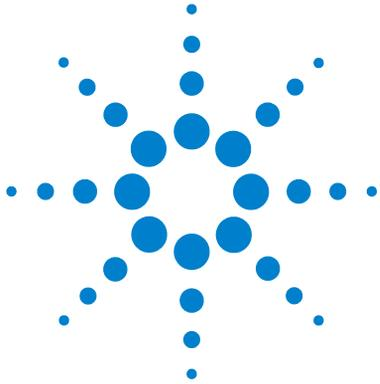

1 Getting Started

Check the Shipment and Order List	2
Safety Notice	4
Power Requirements	5
Power On and Check	7
Environmental Requirements	9
Electrostatic Discharge Protection	12

This *Quick Start Guide* helps you in preparing the spectrum analyzer for use. With this guide, you will become familiar with its basic operating and programming information. For more information, please refer to *User's Guide* from: www.agilent.com/find/n9320b

This chapter gives you the information to start using the spectrum analyzer correctly.

Check the Shipment and Order List

After receiving the shipment, first check the shipment and your order list.

Inspect the shipping container and the cushioning material for signs of stress. Retain the shipping materials for future use, as you may wish to ship the analyzer to another location or to Agilent Technologies for service. Verify that the contents of the shipping container are complete.

Each spectrum analyzer includes the following accessories as standard:

Item	Description
USB cable (A-B)	Connection for remote control
N-BNC adapter and BNC cable	Connection for alignment
Printed Quick Start Guide	Documentation
Three-pin power cord	Specific to shipping location
Help kit CD-ROM	Remote control Software Agilent IO libraries suite PDF files for quick start guide & user's guide

Shipping Problems?

If the shipping materials are damaged or the contents of the container are incomplete:

- Contact the nearest Agilent Technologies office to arrange for repair or replacement. You will not need to wait for a claim settlement.
- Keep the shipping materials for the carrier's inspection.
- If you must return an analyzer to Agilent Technologies, use the original (or comparable) shipping materials.

For any questions about your shipment, [Contact Agilent Technologies](#) for consulting and service.

Options

Verify if that the shipment includes your ordered options by checking the option label on the shipping container:

Option	Description	Part number
PA3	3 GHz Preampifier	N9320B-PA3
AMA	AM/FM demodulation	N9320B-AMA
ABA	English printed User's Guide	N9320B-ABA
TG3	3 GHz tracking generator	N9320B-TG3
TR1	RF training kit	N9320B-TR1
1HB	Handle and bumpers	N9320B-1HB
1CM	Rackmount kit	N9320B-1CM
1TC	Hard transit case	N9320B-1TC
UK6	Commercial calibration certificate with testing data	N9320B-UK6

Unless specified otherwise, all options are available when you order a spectrum analyzer; some options are also available as kits that you can order and install/activate after you receive the analyzer. Order kits through your local Agilent Sales and Service Office.

At the time of analyzer purchase, options can be ordered using your product number and the number of the option you are ordering. For example, if you are ordering Option TG3, you would order N9320B-TG3.

If you are ordering an option after the purchase of your analyzer, you will need to add a K to the product number and then specify which option you are ordering. For example, N9320BK-TG3.

For the latest information on Agilent N9320B Spectrum Analyzer options and upgrade kits, visit the following Internet URL:

http://www.agilent.com/find/sa_upgrades

Safety Notice

Read the following warnings and cautions carefully before powering on the spectrum analyzer to ensure personal and instrument safety.

WARNING

Always use a well-grounded, three-pin AC power cord to connect to power source. Personal injury may occur if there is any interruption of the AC power cord. Intentional interruption is prohibited. If this product is to be energized via an external auto transformer for voltage reduction, make sure that its common terminal is connected to a neutral (earthed pole) of the power supply.

WARNING

Personal injury may result if the spectrum analyzer covers are removed. There are no operator-serviceable parts inside. To avoid electrical shock, refer servicing to qualified personnel.

WARNING

Electrical shock may result if the spectrum analyzer is connected to the power supply while cleaning. Do not attempt to clean internally.

CAUTION

Prevent damage to the instrument and ensure protection of the input mixer by limiting average continuous power input to +33 dBm, DC voltage to 50 VDC with ≥ 10 dB input attenuation. Instrument damage may result if these precautions are not followed.

CAUTION

To install the spectrum analyzer in other racks, note that they may promote shock hazards, overheating, dusting contamination, and inferior system performance. Consult your Agilent customer engineer about installation, warranty, and support details.

Power Requirements

The spectrum analyzer has an auto-ranging line voltage input. The AC power supply must meet the following requirements:

Voltage:	100 to 240 VAC (90 to 264 VAC)
Frequency:	50 to 60 Hz
Power:	Maximum 100 W

AC Power Cord

The analyzer is equipped with a three-wire power cord, in accordance with international safety standards. This cable grounds the analyzer cabinet when connected to an appropriate power line outlet. The cable appropriate to the original shipping location is included with the analyzer.

Various AC power cables are available that are unique to specific geographic areas. You can order additional AC power cables for use in different areas. The table **AC Power Cords** lists the available AC power cables, the plug configurations, and identifies the geographic area in which each cable is appropriate.

The detachable power cord is the product disconnecting device. It disconnects the mains circuits from the mains supply before other parts of the product. The front panel switch is only a standby switch and does not disconnect the instrument from LINE power.

AC Power Cords

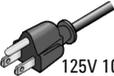
Plug Type	Cable Part Number	Plug ^a Description	For use in Country & Region
 250V 10A	8121-1703	BS 1363/A	Option 900 United Kingdom, Hong Kong, Singapore, Malaysia
 250V 10A	8120-0696	AS 3112:2000	Option 901 Australia, New Zealand
 250V 16A	8120-1692	IEC 83 C4	Option 902 Continental Europe, Korea, Indonesia, Italy, Russia
 125V 10A	8120-1521	CNS 10917-2 /NEMA 5-15P	Option 903 United States, Canada, Taiwan, Mexico
 250V 10A	8120-2296	SEV 1011	Option 906 Switzerland
 230V 15A	8120-4600	SABS 164-1	Option 917 South Africa, India
 125V 15A	8120-4754	JIS C8303	Option 918 Japan
 250V 16A	8120-5181	SI 32	Option 919 Israel
 250V 10A	8120-8377	GB 1002	Option 922 China

a. Plug description describes the plug only. The part number is for the complete cable assembly.

Power On and Check

- 1 Connect the AC power cord into the instrument. Insert the plug into a power socket provided with a protective ground. Set the tilt adjusters for your preference.

Figure 1 Plug in and angle adjustment

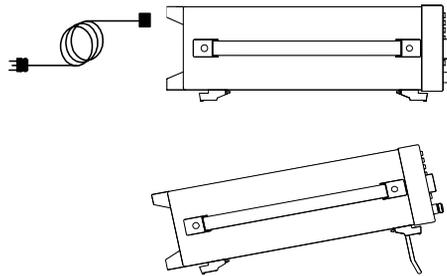

- 2 Press the AC line switch  on the rear panel. The standby LED on the front panel will light and the spectrum analyzer is in standby mode (AC power applied).
- 3 Press the standby switch  on the front panel. The On LED will light, and the spectrum analyzer boots up.

Self-initialization takes about 25 seconds; the spectrum analyzer then defaults to the menu mode. After power on, let the spectrum analyzer warm up for 45 minutes for stabilization.

NOTE

The front panel switch is a standby switch only; it is not a power switch. To completely disconnect the spectrum analyzer from the AC line power, shut off the power switch on the rear panel.

Running Internal Alignments

To meet the instrument performance specifications, the analyzer must periodically be manually aligned.

- 1 Connect a BNC cable with the N-BNC adapter between the **CAL OUT** and **RF IN** front panel connectors.
- 2 After 15-minute warm up, press  > **Alignment > Align > All**

The self alignment takes about 5 minutes.

Check for Instrument Messages

The spectrum analyzer has two categories of instrument messages: error and warning messages. A error message is triggered by operation errors, for example, parameter setting conflicts or data input that is out of the range of a parameter. An warning message may be triggered by hardware defects which could result in damage to instrument.

Here are some tips to check the instrument messages.

- 1 Check the display to see if any messages display in the status bar. Press  > **More > Show Errors** to review each message. Refer to User's Guide for detailed system message descriptions.
- 2 When you have reviewed and resolved all of the error messages, press  > **More > Show Errors > Clear error queue** to delete the messages.
- 3 Cycle the power to the analyzer and re-check to see if the Instrument messages are still there.
- 4 If the error messages cannot be resolved, contact the Agilent Customer Contact Center for assistance or service.

Environmental Requirements

Agilent Technologies has designed this product for use in Installation Category II, Pollution Degree 2, per IEC 61010-1. Agilent has designed the spectrum analyzer for use under the following conditions:

- Indoor use
- Altitude < 3,000 meters
- Operating temperature range: +5 to +45 °C;
Storage temperature range: -20 to +70 °C
- Relative humidity range 15% to 95 %

Ventilation

Ventilation holes are located on the rear panel and one side of the spectrum analyzer cover. Do not allow these holes to be obstructed, as they allow air flow through the spectrum analyzer.

When installing the spectrum analyzer in a cabinet, do not restrict the convection of the analyzer. The ambient temperature outside the cabinet must be less than the maximum operating temperature of the spectrum analyzer by 4 °C for every 100 watts dissipated within the cabinet.

Cleaning Tips

To prevent electrical shock, disconnect the spectrum analyzer from line power before cleaning. Use a dry cloth or one slightly dampened with water to clean the external case parts. Do not attempt to clean internally.

Rack Mount

It is recommended to use the Agilent rackmount kit (option 1CM) to install the spectrum analyzer into a rack.

Do not attempt to rack mount the spectrum analyzer by the front panel handles only. This rackmount kit will allow mounting of the spectrum analyzer with or without handles.

Refer to the following instructions when installing the rackmount kit on the spectrum analyzer.

- 1 Remove feet, key-locks and tilt stands.
- 2 Remove side trim strips and one middle screw per side.

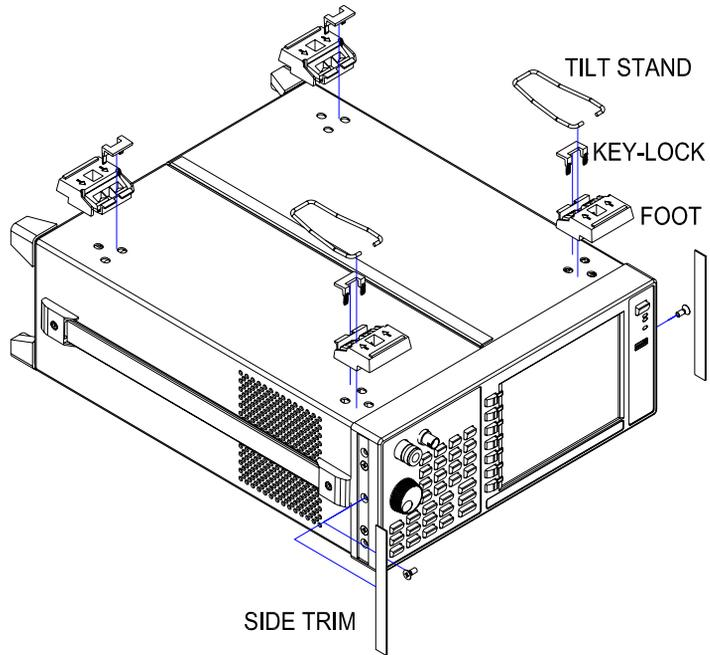

- 3 Attach rackmount flange and front handle assembly with 3 screws per side.

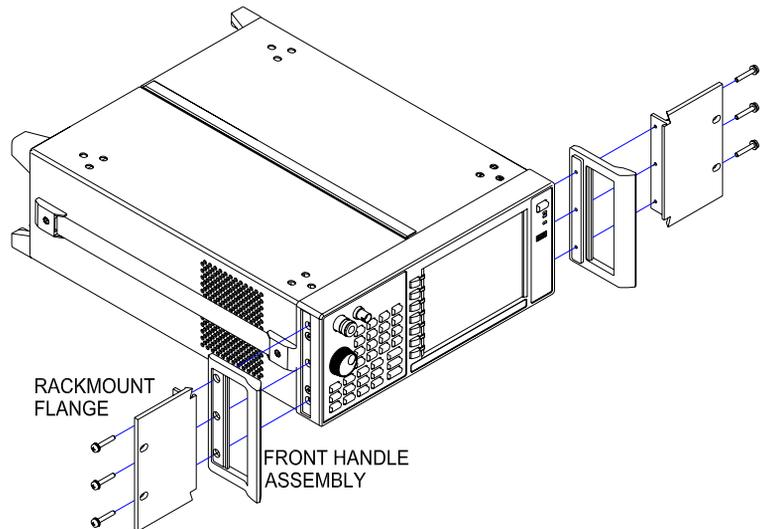

- 4 Attach the spectrum analyzer to the rack using the rackmount flanges with two dress screws per side.

CAUTION

Installing the spectrum analyzers into other racks may promote shock hazards, overheating, dust contamination, and inferior system performance. Consult your Agilent customer engineer about installation, warranty, and support details.

Transit

It is recommended to use the hard transit case (option ITC) for instrument transportation.

Electrostatic Discharge Protection

Electrostatic discharge (ESD) damages or destroys electronic components (the possibility of unseen damage caused by ESD is present whenever transported, stored, or while the instrument is in use).

This product contains components that are easily damaged by electrostatic discharge. To help reduce the possibility of ESD damage that can occur while using test equipment, follow these guidelines:

- 1 Before connecting any coaxial cable to the spectrum analyzer connector for the first time each day, momentarily short the center and outer conductors of the cable together to eliminate any potential electrostatic charges that may exist.
- 2 Personnel should be grounded with an approved type, 1 M Ω resistor-isolated ESD wrist-strap before touching the center pin of any connector, and before removing any assembly from the spectrum analyzer.
- 3 Be sure that all instruments are properly earth grounded to prevent build-up of static charges.

For more information about ESD and how to prevent ESD damage, contact the Electrostatic Discharge Association (<http://www.esda.org>). The ESD standards developed by this agency are sanctioned by the American National Standards Institute (ANSI).

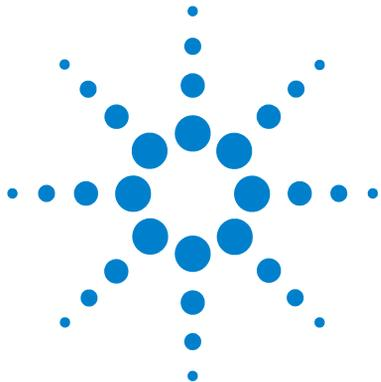

2 N9320B Overview

Agilent N9320B at a Glance	14
Rear Panel Overview	20
Front and rear panel symbols	21

This chapter gives you an overview of the front and rear panels of your analyzer. For details on analyzer keys and remote programming, refer to the N9320B User's Guide.



Agilent N9320B at a Glance

An Agilent N9320B RF Spectrum Analyzer is a swept portable spectrum analyzer with a frequency range of 9 kHz to 3.0 GHz. It can be a fundamental component of an automated system, and be widely used in electronic manufacturing functional/final/QA test systems.

Figure 2 Agilent N9320B RF Spectrum Analyzer

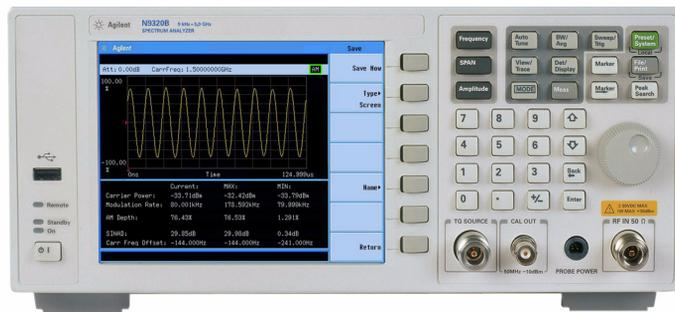

Front Panel at a Glance

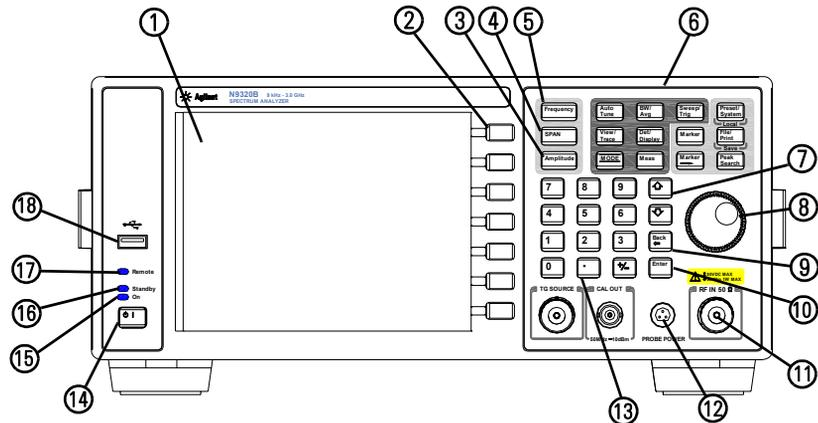

- 1 **Screen** shows information of the current function, including the signal traces, status indicators, and instrument messages. Labels for softkeys are located on the right-hand side of the screen.
- 2 **Softkeys** are the unlabeled keys next to the screen. They activate functions displayed to the left of each key.
- 3 **Amplitude** activates the reference level function and accesses the amplitude softkeys, with which you set functions that affect data on the vertical axis.
- 4 **SPAN** sets the frequency range symmetrically about the center frequency. The frequency-span readout describes the total displayed frequency range.
- 5 **Frequency** activates the center-frequency function, and accesses the menu of frequency functions.
- 6 **Function Keys** relate directly to the following main functions:
 - **Preset/System (Local)** accesses the softkeys to reset the analyzer to a known state, if the analyzer is in the remote mode, pressing this key returns the analyzer to the local mode and enables front-panel control.

- **Auto Tune** Search the signal automatically and locate the signal to the center of the graticule.
 - **BW/Avg** activates the resolution bandwidth function and accesses the softkeys that control the bandwidth functions and averaging.
 - **Sweep/Trig** accesses the softkeys that allow you to set the sweep time, select the sweep mode and trigger mode of the analyzer.
 - **View/Trace** accesses the softkeys that allow you to store and manipulate trace information.
 - **Det/Display** accesses the softkeys that allow you to configure detector functions and control what is displayed on the analyzer, including the display line, graticule and annotation, as well as the testing of trace data against entered limits.
 - **MODE** selects the measurement mode of your analyzer.
 - **Meas** accesses the softkeys that let you make transmitter power measurements such as adjacent channel power, occupied bandwidth, and harmonic distortion, etc.
 - **Marker** accesses the marker control keys that select the type and number of markers and turns them on and off.
 - **Marker→** accesses the marker function softkeys that help you with the measurement.
 - **Peak Search** places a marker on the highest peak.
 - **File/Print** accesses the softkeys that allow you to configure the file and printing system of the analyzer.
- 7 Data Control Keys** including the arrow keys, knob, and numeric keypad, change the numeric value of an active function such as center frequency, start frequency, resolution bandwidth, and marker position.
- 8 RF IN connector** is the signal input for the analyzer. The maximum damage level is average continuous power +40 dBm, DC voltage 50 VDC or max pulse voltage 125 V. The impedance is 50 Ω . (N-type female).

- 9 **PROBE POWER connector** provides power for high-impedance AC probes or other accessories (+15 V, -12 V, 150 mA maximum).
- 10 **CAL OUT connector** provides an amplitude reference signal output of 50 MHz at -10 dBm (BNC female).
- 11 **TG SOURCE connector** N-type female, is the source output for the built-in tracking generator. The impedance is 50 Ω (for Option TG3)

CAUTION

If the tracking generator output power is higher than the maximum power that the device under test can tolerate, it may damage the device under test. Do not exceed the maximum power of DUT.

- 12 **Standby Switch** switches on all functions of the analyzer. To switch the analyzer off, press the switch for at least 2 seconds. This deactivates all the functions but retains power to internal circuits so long as the analyzer is connected to line power.
- 13 **On LED** (green) lights when the analyzer is switched on.
- 14 **Standby LED** (orange) lights when the analyzer is connected to the line power.
- 15 **Remote LED** lights when the analyzer is remotely controlled by a PC via the USB host interface on the rear panel.
- 16 **USB Device Connector** provides a connection between external USB devices and the analyzer, such as a USB memory device.

Display Annotations

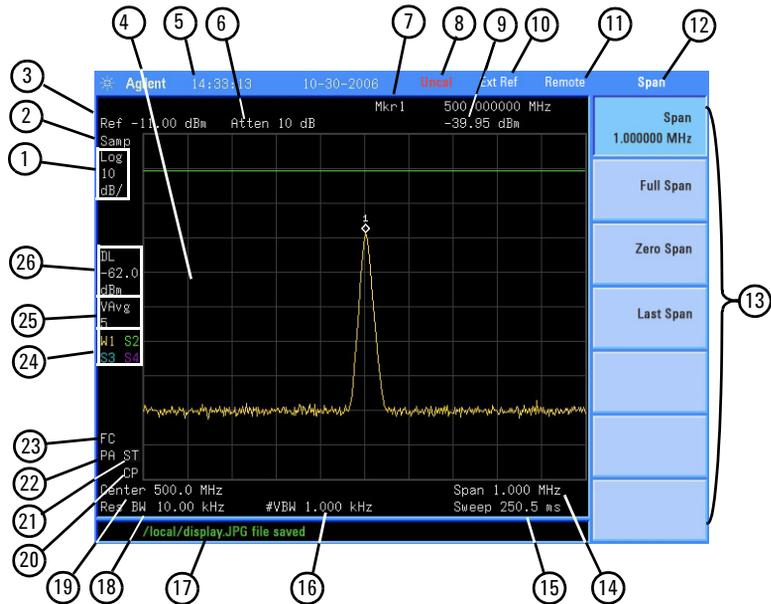

Item	Description	Notes (Associated function key)
1	Amplitude scale	[Amplitude] > Scale Type
2	Detector mode	[Det/Display] > Detector
3	Reference level	[Amplitude] > Ref Level
4	Active function block	The function in use
5	Time and date display	[Preset/System] > Time/Date
6	RF attenuation	[Amplitude] > Attenuation Auto
7	Marker frequency	[Marker] or [Marker] > Function > Frequency Counter
8	Uncal indicator	The readout of amplitude is uncalibrated.
9	Marker amplitude	[Marker]
10	External reference	An external frequency reference is in use.
11	Remote mode	The analyzer is in remote mode
12	Key menu title	Dependent on key selection.

13	Softkey menu	Refer to <i>User's Guide</i> for details.
14	Frequency span	[SPAN]
15	Sweep time	[Sweep/Trig] > Sweep Time
16	Video bandwidth	[Bw/Avg] > Video BW
17	Display status line	Display status and instrument messages.
18	Resolution bandwidth	[Bw/Avg] > Res BW
19	Trigger/Sweep F - free run trigger L - line trigger V - video trigger E - external trigger C - continuous sweep S - single sweep	[Sweep/Trig]
20	Continuous peak	[Peak Search] > Continuous pk
21	Signal track	[SPAN] > Span
22	Internal preamp	[Amplitude] > Int Preamp
23	Key menu title	Dependent on key selection
24	Trace mode W - clear write M - maximum hold m - minimum hold V - view S - store blank	[Marker]
25	Average VAvg - video average PAvg - power average	[Bw/Avg] > Average On Off
26	Display line	[Det/Display] > display Line On Off

Rear Panel Overview

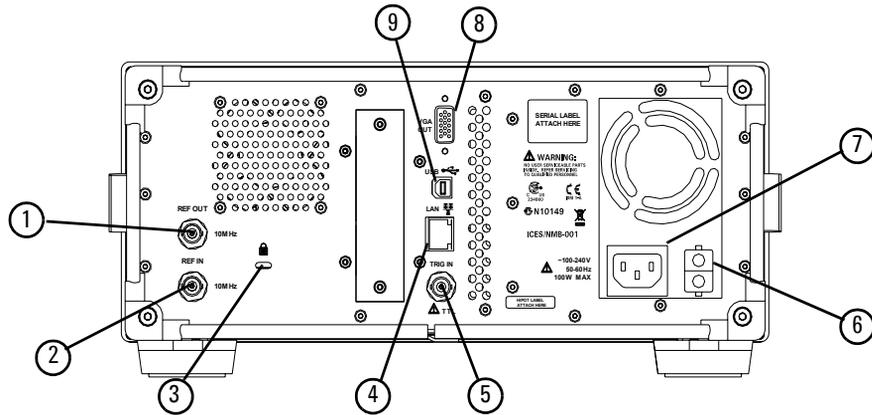

- 1 **REF OUT connector** provides a frequency of 10 MHz, amplitude of -10 dBm reference output. (BNC female)
- 2 **REF IN connector** accepts an external timebase with a frequency of 10 MHz, amplitude of -5 to $+10$ dBm. (BNC female)
- 3 **Kensington Lock** lock the instrument and keep its safety.
- 4 **LAN port** A TCP/IP Interface that is used for remote analyzer operation.
- 5 **EXT TRG IN (TTL) connector** accepts an external voltage input, the positive edge of which triggers the analyzer sweep function. (BNC female)
- 6 **Power switch** isolates the analyzer from the AC line power. After switch on, the analyzer enters into standby mode and the orange standby LED on the front panel lights.
- 7 **AC Power Receptacle** accepts a three-pin line power plug.
- 8 **VGA connector** provides the video output signal to an external monitor or projector. (D-sub 15-pin female)
- 9 **USB Host connector** provides a connection between the analyzer and an PC for remote control.

Front and rear panel symbols



The instruction manual symbol: indicates that the user must refer to specific instructions in the manual.



The CE mark: a registered trademark of the European Community.

ISM1-A

Shows that this is an Industrial Scientific and Medical Group 1 Class A product. (CISPR 11, Clause 4)



The CSA mark: a registered trademark of the Canadian Standards Association International.

ICES/NMB-001

The ISM device complies with Canadian Interference-Causing Equipment Standard-001.
Cet appareil ISM est conforme à la norme NMB-001 du Canada.



The C-Tick mark: a trademark registered to the Australian Communication Media Authority. It indicates compliance with all Australian EMC regulatory information.



marks the “on/standby” position of the switch.



indicates that the instrument requires AC power input.



indicates this product complies with the **WEEE Directive**(2002/96/EC) marking requirements and you must not discard this equipment in domestic household waste. Do not dispose in domestic household waste. To return unwanted products, contact your local Agilent office, or refer to <http://www.agilent.com/environment/product/>

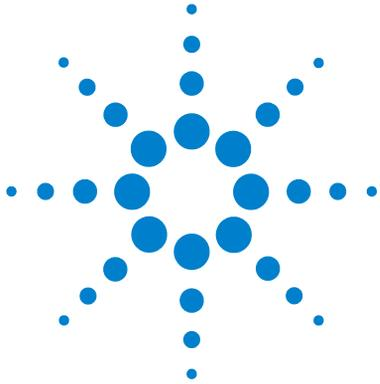

3 Basic Operation

Making a Basic Measurement 24

Some helpful Tips 28

Remote Control 30

This chapter gives you the information to start using the spectrum analyzer correctly.



Making a Basic Measurement

In this guide, the keys labeled with [], for example, **[Preset/System]** refer to front-panel hardkeys. Pressing many of the hardkeys accesses softkey menus that are displayed along the right side of the screen. The softkey menu labels are aligned so that they are located next to the softkeys at the right side of the display screen. For example, **Preset** is a softkey menu selection when first pressing **[Preset/System]**.

Using the Front Panel

This section provides you with the information on using the front panel of the spectrum analyzer.

Entering Data

When setting the measurement parameters, there are several ways to enter or modify the value of the active function:

- Knob** Increments or decrements the current value.
- Arrow Keys** Increments or decrements the current value by a step unit.
- Numeric Keys** Enters a specific value. Then press the desired terminator (either a unit softkey, or **[Enter]** hardkey).
- Unit Softkeys** Terminate (enter) a value with a unit softkey from the menu.
- Enter Key** Terminates an entry when no unit of measure is required, or the instrument uses the default unit.
- Back Key** To delete the current input digit prior to entering the value.

Using Softkeys

Softkeys are used to modify the analyzer function parameter settings. Some examples of softkey types are:

- Toggle** Turn on or off an instrument state.
- Submenu** Displays a secondary menu of softkeys, **{More}**.
- Choice** Selecting from a list of standard values or filenames.
- Adjust** Highlights the softkey and sets the active function.

Presetting the Spectrum Analyzer

Preset function provides a known instrument status for making measurements. There are two types of presets, factory and user:

Factory Preset When this preset type is selected, it restores the analyzer to its factory-defined state. A set of known instrument parameter settings defined by the factory.

User Preset Restores the analyzer to a user-defined state. A set of user defined instrument parameter settings saved for assisting the user in quickly returning to known a instrument measurement setup.

Press  > **Pwr on/Preset** > **Preset Type** to select the preset type.

When **Preset Type** is set to **Factory**, pressing  > **Preset** triggers a factory preset condition. The instrument will immediately return to the factory default instrument parameter setting.

When **Preset Type** is set to **User**, pressing  > **Preset** displays both **User Preset** and **Factory Preset** softkeys. The user may then select the preset desired from the softkey menu selections.

Setting up a User Preset

To quickly return to instrument settings that are user defined, perform the following steps to save the instrument state as the user-defined preset:

- 1 Set the instrument parameters to the values and settings necessary for the user preset state. This would include the frequency, span, amplitude, BW, and measurement type and any other setup details desired.
- 2 Press  > **Pwr on/Preset** > **Save User Preset**, to save the current instrument settings as the 'user preset' state. The user preset will not affect the default factory preset settings. User preset settings can be changed and saved at any time.

Viewing a Signal

Refer to the procedures below to view a signal.

- 1 Press **Preset/System** > **Pow on/Preset** > **Preset Type** > **Factory** to enable the factory-defined preset state.
- 2 Press **Preset/System** > **Presets** to restore the analyzer to its factory-defined state.
- 3 Connect the 10 MHz **REF OUT** on the rear panel to the front-panel **RF IN**.

Setting the Reference Level and Center Frequency

- 1 Press **Amplitude** > **10** > **dBm** to set 10 dBm reference level.
- 2 Press **Frequency** > **30** > **MHz** to set 30 MHz to center frequency.

Setting Frequency Span

Press **SPAN** > **50** > **MHz** to set 50 MHz frequency span.

NOTE

Changing the reference level changes the amplitude value of the top graticule line. Changing the center frequency changes the horizontal placement of the signal on the display. Increasing the span will increase the frequency range that appears horizontally across the display.

Reading Frequency and Amplitude

- 1 Press **Peak Search** to place a marker (labeled 1) on the 10 MHz peak.

Note that the frequency and amplitude of the marker appear both in the active function block, and in the upper-right corner of the screen.

Figure 3 10 MHz Internal Reference Signal

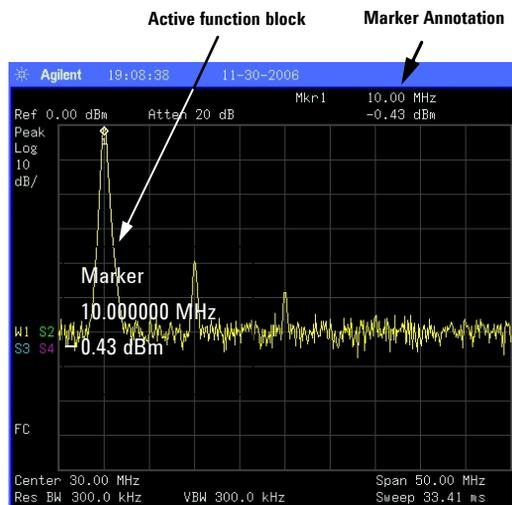

- 2 Use the knob, the arrow keys, or the softkeys in the **Peak Search** menu to move the marker. The marker information will be displayed in the upper-right corner of the screen.

Changing Reference Level

- 1 Press **Amplitude** and note that reference level (**Ref Level**) is now the active function.
- 2 Press **Marker** > **Mkr-> Ref Lvl.**

NOTE

Changing the reference level changes the amplitude value of the top graticule line.

Some helpful Tips

The following contains information to help in using and maintaining the instrument for optimum operation, including alignment, external reference, firmware update and option activation.

Set system date and time

Press  > **date/time** to set the appropriate date and time.

Enable the Options

Option license key information is required to enable product options. Contact your nearest Agilent Office for purchasing a license. Refer to the procedures below to activate the options you have purchased.

- 1 Press  > **More > More > Licensing > Option**
- 2 Enter the option number to be enabled. Press **[Enter]** to confirm your input.
- 3 Press  > **More > More > Licensing > License key**
- 4 Enter the license key information. Press **[Enter]** to confirm your input and terminate the license key input. The option will be enabled immediately.

Using an External Reference

To use an external 10 MHz source as the reference frequency, connect the external reference source to the **REF IN** connector on the rear panel. An **EXT REF** indicator will display in the upper bar of the display. The signal level must be in the range of -5 to +10 dBm.

Firmware Update

Press  > **More** > **Show software** to view the firmware revision of your analyzer. If you call Agilent Technologies regarding your analyzer, it is helpful to have this revision and the analyzer serial number available. To update the firmware, refer to:

<http://www.agilent.com/find/n9320b>

Follow this procedure to finish the firmware update:

- 1 Download the firmware package from web. Extract and copy the file *version* and folder “*n9320b*” into the root directory of a USB stick.
- 2 Turn the N9320B off. Then insert the USB stick into the USB connector.
- 3 Cycle your spectrum analyzer, the instrument will perform the update process automatically. The upgrade procedure will take about 8-12 minutes.

CAUTION

Any interruption during the update process will result in update failure and system data lost. Do not remove the USB storage device until the update is finished.

Remote Control

The N9320B spectrum analyzer is capable of being connected to a PC via USB or LAN connection, allowing the analyzer to be operated in remote mode.

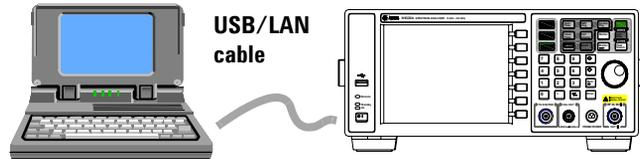

The configuration for setting up a remote control for your N9320B is easily done: connect your N9320B using a USB/network cable to a PC which has had Agilent IO libraries suite installed.

When connecting a PC to the spectrum analyzer, power on the spectrum analyzer. The PC will then detect if there is a connection to the spectrum analyzer.

To maximize the flexibility of the remote control feature, use SCPI commands to create your own programs.

Installing Agilent IO libraries suite

Before trying to remotely control your N9320B, you need to install **Agilent IO libraries suite** on your PC. The Agilent IO libraries suite is a general purpose instrument driver for all Agilent test and measurement instruments. This software is in the documentation CD with the shipment, or download the latest version from

<http://www.agilent.com/find/iolib>

Follow the windows wizard to finish the installation. Then, you have successfully set up an environment for remotely controlling your N9320B.

USB Connection

- 1 Switch on your N9320B. The standby LED on the front panel is turned off and the green LED is turned on.
- 2 Connect your PC to instrument with the USB cable as below.

Figure 4 USB cable for remote control

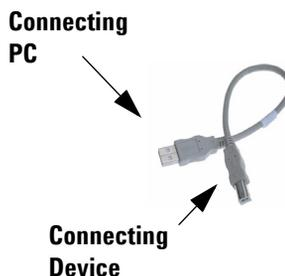

All of the USB ports are compatible with the USB 2.0 and 1.1 specification. For further information on remote control and programming, please refer to the *N9320B User's Guide* in the *N9320B Help Kit CD*.

LAN Connection

After connect the N9320B to the PC with network cable, please configure the LAN parameters before remote control.

Static IP

The instrument is pre-configured to obtain the static IP setting. After connect the N9320B to LAN with network cable, Set the proper IP Address, Gateway and Subnet Mask to complete the LAN configuration. Those setting will be work once you press **{Apply}** softkey in IP Admin submenu.

DHCP

Select the **DHCP IP** to obtain an IP Address automatically. The related LAN parameters will be set once pressing **{Apply}** softkey in IP Admin submenu.

3 Basic Operation

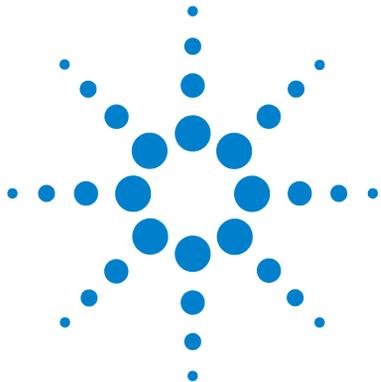

4 Troubleshooting

Check the basics 34

Contact Agilent Technologies 36

This chapter includes information on how to check for a problem with your Agilent Technologies spectrum analyzer, and how to return it for service.

If you experience a problem or would like additional information about your analyzer, Agilent Technologies' worldwide organization is ready to provide the support you need.



Check the basics

Before calling Agilent Technologies, or returning an analyzer for service, perform the quick checks listed below. This check may eliminate the problem.

- Is there power at the receptacle?
- Is the analyzer turned on? Listen for internal fan noise to determine if the analyzer cooling fan is running. Feel the rear side of the analyzer for air flow.
- If other equipment, cables, and connectors are being used with your spectrum analyzer, make sure they are connected properly and operating correctly.
- Review the measurement procedures being performed when the problem first appeared. Make sure all of the settings are correct.
- If the analyzer is not functioning as expected, return the analyzer to a known state by pressing **Preset**.

NOTE

Some analyzer settings are not affected by a Preset. If you wish to reset the analyzer configuration to the state it was in when it was originally sent from the factory, press System, Power On/Preset, Preset Type, Factory. Then press the green Preset key on the front panel.

- Is the measurement being performed, and the results that are expected, within the specifications and capabilities of the analyzer? Refer to the *Technical Overview* for your analyzer.
- Is the analyzer displaying an error message? If so, refer to *User's Guide* for details.
- To meet specifications, the analyzer must be aligned. For more information on how to align the analyzer, refer to “[Running Internal Alignments](#)” on page 8.

WARNING

No operator serviceable parts inside. Refer servicing to qualified personnel. To prevent electrical shock, do not remove covers.

NOTE

If the analyzer is still under warranty or is covered by a maintenance contract, it will be repaired under the terms of the warranty or plan as below.

If the analyzer is no longer under warranty or is not covered by an Agilent Technologies maintenance plan, Agilent Technologies will notify you of the cost of the repair after examining the analyzer.

If a problem persists, please contact the Agilent Technologies office for further information and service.

Warranty and Service Options

Agilent N9320B spectrum analyzer provides 1-year return-to-Agilent warranty as standard.

Agilent Technologies offers several optional maintenance plans to service your analyzer after the warranty has expired:

R-51B-001-3C

extends this service to 3 years.

R-50C-011-3

Agilent calibration upfront support plan, 3-year coverage.

The calibration cycle of N9320B RF spectrum analyzer is one year.

NOTE

A button cell provides power to the real time clock of the spectrum analyzer. It is not rechargeable. If you find your N9320B encounters a clock defect, please contact your nearest Agilent Customer Contact Center (CCC) for service.

Contact Agilent Technologies

Agilent Technologies has offices around the world to provide you with complete support for your spectrum analyzer. To obtain servicing information or to order replacement parts, contact the Agilent Technologies customer contact center listed below. In any correspondence or telephone conversations, refer to your spectrum analyzer by its product number and full serial number.

Press  > **More** > **Show System** to find those information.

Online assistance: <http://www.agilent.com/find/assist>

United States

(tel) 800 829 4444
(fax) 800 829 4433

Canada

(tel) 877 894 4414
(fax) 800 746 4866

China

(tel) 800 810 0189
(fax) 800 820 2816

Europe

(tel) +31 20 547 2323
(fax) +31 20 547 2390

Japan

(tel) +81 426 56 7832
(fax) +81 426 56 7840

Korea

(tel) 080 769 0800
(fax) 080 769 0900

Latin America

(tel) +1 (305) 269 7500

Taiwan

(tel) 0800 047 866
(fax) 0800 286 331

Australia

(tel) 1 800 629 485
(fax) +61 (3) 9210 5947

Other Asia Pacific Countries

(tel) +65 6375 8100
(fax) +65 6755 0042
Email: tm_ap@agilent.com

Factory Preset State			
Attenuation	20 dB (Auto)	Average Type	Video (Auto)
Center frequency	1.5 GHz	Averaging	1(Off)
CF step size	300 MHz	Peak Excursion	6 dB
Start Frequency	0 Hz	Peak Threshold	-90 dBm
Stop Frequency	3 GHz	Peak Search Type	Max Value
Signal Track	Off	Peak Table	Off
Span	3 GHz	Peak Sort	Amplitude
Reference level	0 dBm	Continuous Pk	Off
Log scale/Division	10 dB	Delta Pair	Delta
Int Preamp	Off	Span Pair	Center
Trace 1	Clear Write	Trigger	Free Run
Trace 2, 3, 4	Blank	Markers	Normal (Off)
Sweep Time	100.2 ms (Auto)	Marker Delta	Off
Sweep	Continuous	Marker Table	Off
Limit	Off	Measure	Meas Off
Limit line testing	Off	File Catalog	Local
Limit point	0	File Type	State
Detector	Peak (Auto)	File Sort	By Date
Display line	-25 dBm (Off)	Phase Noise	Off
Video bandwidth	3 MHz (Auto)	Optimize phase noise	Off
VBW/RBW ratio	1.000 (Auto)	Frequency Counter	Off
Resolution bandwidth	3 MHz (Auto)	Frequency counter resolution	1 kHz (Auto)

www.agilent.com

© Agilent Technologies, Inc. 2008

Printed in China
Aug 2008



N9320-90009

